

2017

Connecting technology



MÁS DE 25 AÑOS DE EXPERIENCIA EN EL SECTOR ELÉCTRICO INTERNACIONAL
MORE THAN 25 YEARS OF EXPERIENCE IN THE INTERNATIONAL ELECTRIC SECTOR

famatel
PROFESSIONAL

EMPRESA	4
COMPANY	
NORMATIVAS	10
REGULATIONS	
CLAVIJAS, BASES, ADAPTADORES, ENROLLACABLES E INTERRUPTORES DE CORTE IP44 / IP67	14
PLUGS, SOCKETS, ADAPTATORS, CABLEREELS AND SAFETY SWITCHES IP44 / IP67	
1 TOMAS Y CLAVIJAS INDUSTRIALES IP44 / IP67; 16A - 125A	16
INDUSTRIAL PLUGS AND SOCKETS IP44 / IP67; 16A - 125A	
1.1 CONEXIÓN POR TORNILLOS SpeedPro	20
SCREW CONNECTION SpeedPro	
1.2 CONEXIÓN RÁPIDA SIN TORNILLOS TOP SpeedPro	44
SCREWLESS QUICK CONNECTION TOP SpeedPro	
2 BASES INTERBLOCANTES INDUSTRIALES IP44/67	48
INDUSTRIAL SWITCHED INTERLOCKED SOCKETS IP44/67	
3 TOMAS DE CORRIENTE DE CUADRO 50x50	72
PANEL SOCKETS OUTLETS 50x50	
4 APLICACIONES ESPECIALES	78
SPECIAL APPLICATIONS	
4.1 CLAVIJAS Y BASES DE MUY BAJA TENSIÓN IP44/67	82
EXTRA LOW VOLTAGE PLUGS AND SOCKETS IP44/67	
4.2 CLAVIJAS Y BASES PARA CONTENEDORES SpeedPRO IP67	90
CONTAINER SpeedPRO PLUGS AND SOCKETS IP67	
4.3 CLAVIJAS Y BASES SpeedPRO IP44 Y EQUIPAMIENTO PARA EVENTOS	96
SpeedPRO PLUGS AND SOCKETS IP44 AND EVENT EQUIPMENT	
5 ADAPTADORES INDUSTRIALES IP44 / IP67	100
INDUSTRIAL ADAPTORS IP44 / IP67	
6 ENROLLACABLES INDUSTRIALES IP67	116
INDUSTRIAL CABLE REEL IP67	
7 INTERRUPTORES DE CORTE IP65	122
SAFETY SWITCHES IP65	
ARMARIOS Y MIRILLAS DE MANIOBRA	126
ENCLOSURES AND FUSE WINDOW	
8.1 CAJAS INDUSTRIALES IP65	128
INDUSTRIAL ENCLOSURES IP65	
8.2 CAJAS INDUSTRIALES CABLEADAS	162
CABLED INDUSTRIAL ENCLOSURES	
8.3 ARMARIOS DE OBRA	178
DISTRIBUTION ENCLOSURES FOR CONSTRUCTION SITES	
8.4 CAJAS DE GOMA	184
RUBBER BOXES	
8.5 ARMARIOS ESTANCOS TERMOPLÁSTICOS IP65	190
WATERTIGHT ENCLOSURES IP65	
8.6 ARMARIOS DE SUPERFICIE IP65 - AcquaPLUS	196
WALL MOUNTED ENCLOSURES IP65 - AcquaPLUS	
8.7 ARMARIOS DE SUPERFICIE IP65 - Acqua	202
WALL MOUNTED ENCLOSURES IP65 - Acqua	
8.8 CAJAS ESTANCAS	214
SEALED BOXES	
9 MIRILLAS DE MANIOBRA IP66/67	244
HINGLED WINDOW-FUSE WINDOWS IP66/67	
ÍNDICE POR REFERENCIAS	249
INDEX BY ITEMS	



PENSAMOS Y ACTUAMOS DE MANERA GLOBAL - FAMATEL SPA
WE THINK AND ACT GLOBALLY - FAMATEL SPA

Creer en este proyecto nos ha permitido hacerlo realidad traspasando fronteras. Nos hemos convertido en una empresa global donde las personas, su actitud y su conocimiento forman el eje vertebrador del proyecto Famatel.

Nuestra estrategia corporativa, apoyada en los pilares del trabajo en equipo y el respeto a la diversidad, nos ha proyectado a estar presentes en más de 60 países con 3 centros de producción y 7 filiales propias.

Un equipo autoexigente, honesto y muy motivado se esfuerza cada día para consolidar nuestro posicionamiento en el mercado nacional e internacional fortaleciendo nuestras relaciones con clientes y proveedores.

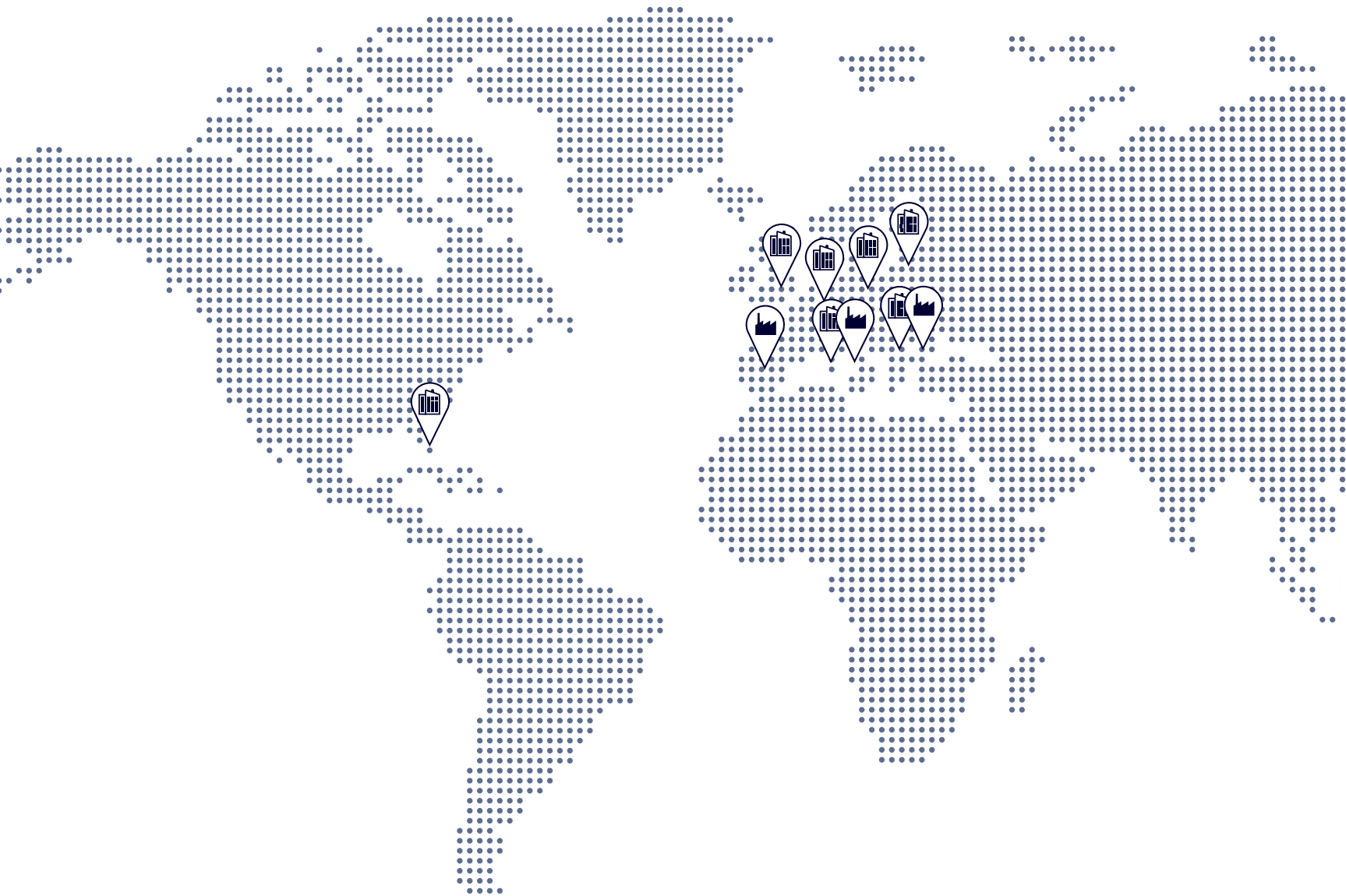

By believing in this project we've truly crossed borders. We've become a global business where people, their attitude and their knowledge are the backbone to the Famatel project.

Our corporate strategy rests on the pillars of teamwork and respect for diversity; it's led us to have a presence in over 60 countries with 3 production centers and 7 subsidiaries.

A demanding, honest and well-motivated team strive every day to consolidate our position on the national and international market by strengthening our relationship with clients and suppliers alike.

-  **Famatel filiales**
Famatel subsidiary
-  **Famatel fábricas**
Famatel factories

APOSTAMOS POR EL TRABAJO BIEN HECHO
COMMITMENT TO A JOB WELL DONE

I+D+I
R&D&I

Para alcanzar la excelencia investigamos, trabajamos y descubrimos. En definitiva, innovamos. Porque la innovación es lo que nos hace diferentes y nos conecta con el consumidor.

Nuestra presencia global proporciona y enriquece de información y experiencias a nuestros departamentos de I+D+I que desarrollan productos adaptados a las particularidades y legislación de cada mercado.

In order to achieve excellence, we are dedicated to carrying out research, working hard and making discoveries. In short, we innovate. Innovation is what sets us apart and makes us connect with the consumer.

Our global presence provides our R&D&I departments with enriched information and experience, which help them to develop products adapted to the specific needs and legislation in each market.

PRODUCCIÓN
PRODUCTION

Concentramos todos nuestros esfuerzos para mantener un alto nivel de desarrollo en aquellas tecnologías que son fundamentales en la fabricación de nuestros productos.

Para ofrecer productos de un alto valor añadido y garantizar un servicio rápido y eficaz a la demanda del mercado aplicamos un equilibrio entre la flexibilidad y la especialización. Damos respuesta a las necesidades del mercado nacional e internacional con nuestros más de 2.000 productos estándar y sus múltiples variables.

We concentrate all our efforts to maintain a high level of development among those technologies that are essential to the manufacturing of our products.

To offer high value-added products and guarantee a quick and effective service that meets the demands of the market, we apply a balance between flexibility and specialization. We meet the needs of the national and international market with more than 2000 standard products and their multiple variables.



DISTRIBUCIÓN Y LOGÍSTICA
DISTRIBUTION AND LOGISTICS

Nuestro sistema logístico acerca el producto al consumidor mediante una cobertura nacional e internacional a través de nuestros más de 2.000 clientes nacionales, 60 distribuidores internacionales y 7 filiales propias.

Conscientes de la importancia de ofrecer un servicio rápido y eficiente a cada uno de nuestros clientes, nuestro equipo trabaja para implementar la mejor tecnología y procesos.

Our logistical system brings the product to the consumer with national and international coverage through more than 2000 national clients, 60 international distributors and 7 subsidiaries.

Our team understands the importance of offering each of our clients quick and efficient service, and works hard to implement the best technology and processes.



LA CALIDAD ES NUESTRA PRIORIDAD
QUALITY IS OUR PRIORITY

Una parte muy importante de nuestra política empresarial está basada en establecer y mantener un efectivo y eficiente Programa de Calidad presente en todos los procesos y ámbitos de la empresa.

El sistema integrado de Gestión de Calidad Famatel se basa en los requisitos de la norma UNE-EN ISO 9001: 2008, así como en otras normas nacionales e internacionales aplicables. Su cumplimiento está liderado por la Alta Dirección y responde al compromiso de toda la organización.

An important part of our business policy is based on establishing an effective and efficient Quality Program that is built into all of our business' processes and departments.

The integrated Famatel Quality Management System is based on the requirements of UNE-EN ISO 9001:2008, as well as other applicable national and international standards. Compliance is headed up by our Senior Management, and is part of the whole organization's commitment.



Aseguramos el cumplimiento de las normativas nacionales e internacionales de todos los productos fabricados por Famatel. Nuestro departamento de I+D+I, a través de nuestros propios laboratorios y en colaboración con entidades certificadoras, garantiza la realización de todos los ensayos necesarios que avalan la calidad de nuestros productos y el cumplimiento de las normativas vigentes.

We guarantee compliance with national and international standards for all products manufactured by Famatel. Our R&D&I department uses its many internal labs, collaborating with certifying agencies, to guarantee all necessary trials are carried out to vouch for the quality of our products and compliance with the current standards.



PROYECTOS REALIZADOS 2016
FULFILLED PROJECTS 2016

TELECOMUNICACIONES

Proyecto cooperado con el operador de telecomunicaciones "VIP", Croacia

TELECOMMUNICATIONS

Project-Cooperation with the telecommunications operator "VIP", Croatia

PUERTO

Proyecto astilleros de Cádiz, España
Proyecto puerto Las Palmas de Gran Canaria, España, para contenedores refrigerados
Proyecto terminal de contenedores puerto de Marsella, Francia

HARBOR

Cádiz, Spain, shipyard project
Reefer containers project in Las Palmas de Gran Canaria Port, Spain
Loading terminal Marseille port project, France

HOSPITAL

Proyecto Hospital en Saint-Étienne, Francia

HOSPITAL

Saint-Étienne Hospital project, France

AEROPUERTO

Proyecto Aeropuerto de Málaga, España
Proyecto Aeropuerto terminal 1 de Barcelona, España

AIRPORT

Málaga airport project, Spain
Terminal 1 Barcelona airport project, Spain

METRO

Proyecto Metro Línea 1 de Barcelona, España
Proyecto ampliación Línea de metro en Hong Kong
Proyecto ampliación Línea de metro en Doha, Qatar

METRO

Subway Line 1 project in Barcelona, Spain
Extension subway line in Hong Kong
Extension subway line in Doha, Qatar

INDUSTRIA

Proyecto Cervecería Boliviana Nacional CBN, Planta Taquiña, Bolivia
Proyecto planta de Volkswagen, Polonia

INDUSTRY

Bolivian National Brewery CBN project, Taquiña plant, Bolivia
Volkswagen plant project, Poland

ENERGIA

Proyecto subestación eléctrica. Qatar QEWC
Proyecto aerogeneradores eólicos en Sierra de Minas, Uruguay
Planta solar Kazajistán
Refinería Repsol, Puerto Llano, España
Proyecto Refinería Barrancabermeja, Colombia
Proyecto planta de gas Pemex, Méjico

ENERGY

Electric substation project in Qatar, QEWC
Wind turbine project in Sierra de Minas, Uruguay
Solar plant in Kazajastan
Repsol refinery in Puerto Llano, Spain
Refinery project in Barrancabermeja, Colombia
Gas Pemex plant project in Mexico

MINAS

Proyecto Mina Chinalco, Perú

MINES

Chinalco Mine project in Peru

EVENTOS

Proyecto estadio de futbol "Camp Nou", Barcelona, España

EVENTS

"Camp Nou" football stadium project, Barcelona, Spain

CENTRO PENITENCIARIO

Centro Penitenciario Las Palmas de Gran Canaria, España

PENITENTIARY

Penitentiary in Las Palmas de Gran Canaria, Spain





CARACTERÍSTICAS TÉCNICAS / TECHNICAL DATA

Norma / Norm	IEC/CEI/EN 60309-1 / IEC/CEI/EN 60309-2		
Características técnicas / Technical data			
Tensión de utilización / Operating voltage	100-500V	Temperatura de uso según norma de referencia / Temperature of use according to the norm	-25°C / +40°C
Tensión de aislamiento / Insulating voltage	500V	Prueba de hilo incandescente (IEC / EN 60695-2-10) / Glow wire test (IEC / EN 60695-2-10)	650°C / 850°C
Frecuencia / Frequency	C.C. -50/500Hz	Material / Material	Poliamida 6 / ABS Polyamide 6 / ABS
Intensidad Nominal / Rated current	16A-32A-63A-125A	Resistencia al impacto (IEC/EN 62262) / Impact resistance (IEC / EN 60695-2-10)	IK08
Grado de Protección (IP IEC / EN 60529) / Protection degree (IP IEC / EN 60529)	IP44/IP67	Material de contacto / Contact material	Latón / Latón Niquelado Brass / Nickel-plated Brass
Máxima temperatura de funcionamiento TESTADA / Maximum operating temperature TESTED	+70°C		

OPCIONES DE CABLEADO / CABLING OPERATIONS

La siguiente tabla nos indica la capacidad de conexión de los borne. Sección de los conductores a conectar (mm²/awg). Según la norma CEI EN 60309-1.

The following table shows the conductor cross sections. Section of the conductors in mm²/awg accordingly to the Norm CEI EN 60309-1.

Intensidad Nominal / Rated current	Clavija prolongador móviles y base conductora / Plugs and connectors		Base fija / Panel mounting and wall mounting sockets outlets	
	Min.	Max.	Min.	Max.
16A	1	2,5	1,5	4
32A	2,5	6	2,5	10
63A	6	16	6	25
125A	16	50	16	70

La siguiente tabla nos indica el diámetro máximo de cable admisible por el prensa cable. Según norma CEI EN60309-1.

The following table shows the maximum diameter of cable acceptable by the cable gland accordingly to the Norm CEI EN 60309-1.

Intensidad Nominal / Rated current	Ø Exterior mm / Ø External mm	
	Min.	Max.
16A	8,1	15,3
32A	11,5	21,3
63A	17,3	31,3
125A	26	48,48

Resistencia a los agentes químicos y atmosféricos / Chemical Resistance

DISOLVENTES / SOLVENTS										ÁCIDOS / ACIDS						BASES			
BENZOL / BENZOL		ACETONA / ACETONE		ALCOHOL / ALCOHOL		ACEITES / OILS		RAYOS UV / UV DEGREES		SOLUCIÓN SALINA / SALT SOLUTION		CONCENTRADOS / CONCENTRATED		DILUIDOS / DILUTED		CONCENTRADOS / CONCENTRATED		DILUIDOS / DILUTED	
PA6	PC/ABS	PA6	PC/ABS	PA6	PC/ABS	PA6	PC/ABS	PA6	PC/ABS	PA6	PC/ABS	PA6	PC/ABS	PA6	PC/ABS	PA6	PC/ABS	PA6	PC/ABS
+	0	+	0	+	+	+	+	+	+	***	***	***	***	***	***	***	***	***	***

“+” Resistente / Resistant “0” Condicionalmente resistente / Conditionally resistant “***” Debido a la gran variedad y diferentes concentraciones, consultar con el fabricante / Due to the large variety and concentrations request to the producer

Contacto piloto

Sistema de seguridad de conexionado que nos permite la apertura y el cierre de la corriente una vez insertada o extraída la clavija. El contacto piloto es un contacto auxiliar para niveles de corriente de 63A-125A.

Las clavijas se suministran con contacto piloto y las tomas bajo demanda.

Pilot contact swicht

Connection safety system that allows to open and close the current once its inserted or pulled the plug. The pilot contact its an auxiliary contact for levels of current from 63A-125A.

Plugs are provided including pilot contact, but the sockets only under demand.

Posición horaria / Clock positions

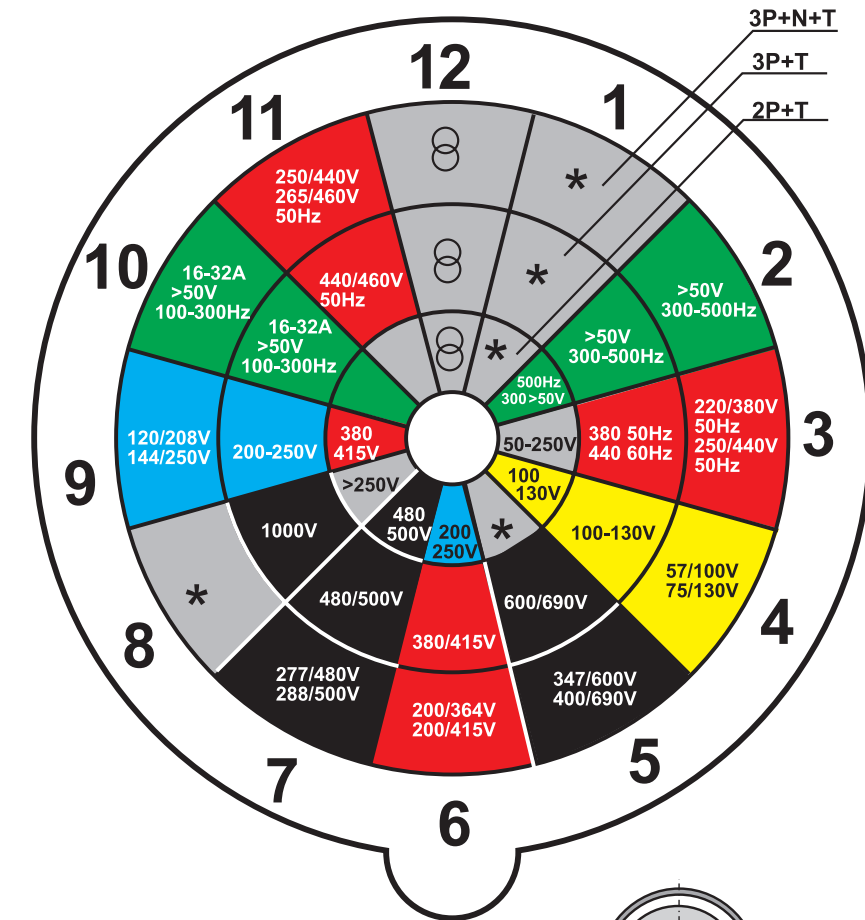

Código de colores / Colour coding
20-25V
40-50V
100-130V
200-250V
380-480V
500-1000V
>60-500Hz

Ejemplo / Example	Posición horaria / Position of the earthing contact
Utilización normal / Normal utilization	h 6
Contenedores fríos / Reefer Container Installations	h 3
Instalaciones marítimas, portuarias, navales / Shipboard Installations	h 11
Para alim. por transf. aisl. (TST) / Supply from an isolating transformer	h 12
Para corriente continua / Direct Current	50 a 250 V h 3 más de 250 V h 8
Para alta frecuencia / For high frequency	100 a 300 Hz h 4 300 a 500 Hz h 2
Tensiones específicas / Special voltage	100 a 300 V h 4 480 a 500 V h 7 600 a 690 V h 5

GRADOS DE PROTECCIÓN / PROTECTION DEGREE

1º CIFRA / 1st DIGIT

Protección frente a partículas sólidas
Protection against ingress of solid objects

IP	Ejemplo Example	Protección Protection	
0		Ninguna No protection	
1		Impide la penetración de una esfera de Ø 50 mm. Protege contra contacto accidental	Against solid bodies with Ø superior to 50 mm (ex. Contact with a finger of the hand)
2		Impide la penetración de una esfera de Ø 50 mm	Against solid bodies with Ø superior to 12 mm (ex. Contact with a finger of the hand)
3		Impide la penetración de una sonda Ø 2,5 mm	Against solid bodies with Ø superior to 25 mm (ex. Contact with a finger of the hand)
4		Impide la penetración de una sonda de Ø 1 mm	Against solid bodies with Ø superior to 1 mm (ex. Contact with a finger of the hand)
5		Protegida contra la penetración de polvo (acumulación no peligrosa)	Against dust (no noxious deposit)
6		Estanqueidad total al polvo	Total against dust

2º CIFRA / 2nd DIGIT

Protección al ingreso de agua
Protection of the materials against harmful ingress of water

IP	Ejemplo Example	Protección Protection	
0		Ninguna No protection	
1		Contra la caída vertical de gotas de agua	Against the vertical falling of drops of water
2		Contra la caída de gotas de agua con una inclinación de 15° de la vertical	Against the vertical falling of drops of water from an inclination of 15°
3		Contra la caída de gotas de agua con una inclinación de 60° de la vertical	Against the vertical falling of drops of water from an inclination of 60°
4		Contra salpicaduras de agua desde todas las direcciones	Against water splashing against the enclosure from any direction
5		Protegida contra los chorros de agua, penetración limitada permitida	Against water jets projected against the enclosure from any direction
6		Protegida contra fuertes chorros de agua, contra la mar gruesa	Against powerful water jets similar to sea waves
7		Protegida contra los efectos de la inmersión entre 150 mm y 1 m	Against the effects of a temporary submersion up to 1 m
8		Protegida contra los efectos de la inmersión controlada a las profundidades específicas	Against the effects of an immersion into water

GRADOS DE IMPACTO / IMPACT DEGREE

Grado IK Rated current	IK 00	IK 01	IK 02	IK 03	IK 04	IK 05	IK 06	IK 07	IK 08	IK 09	IK 10
Energía (J) Load energy in Joule	--	0,15	0,20	0,35	0,50	0,70	1	2	5	10	20
Masa y altura de la pieza de golpeo Mass and high of the piece impacting	--	0,2 kg 70 mm	0,2 kg 100 mm	0,2 kg 175 mm	0,2 kg 250 mm	0,2 kg 350 mm	0,5 kg 200 mm	0,5 kg 400 mm	1,7 kg 295 mm	5 kg 200 mm	5 kg 400 mm

DIMENSIONES DE ROSCA Y ORIFICIO / THREAD AND HOLE DIMENSIONS

Información técnica para montaje / Technical info for mounting

Rosca métrica EN 60423 (para conectores glándula EN 50 262)

Tipo de rosca Thread type	Ø D1	P	Ø D2	Rosca / Thread Ø D3
M12 x 1.5	12	1.5	10.6	12.3 - 0.2
M16 x 1.5	16	1.5	14.6	16.3 - 0.2
M20 x 1.5	20	1.5	18.6	20.3 - 0.2
M25 x 1.5	25	1.5	23.6	25.3 - 0.2
M32 x 1.5	32	1.5	30.6	32.3 - 0.2
M40 x 1.5	40	1.5	38.6	40.4 - 0.3
M50 x 1.5	50	1.5	48.6	50.4 - 0.3
M63 x 1.5	63	1.5	61.6	63.4 - 0.3

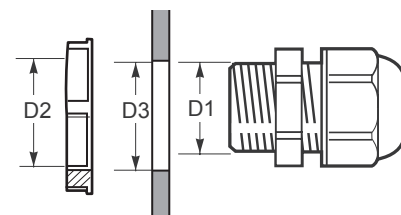

D1 = Ø central
D2 = Ø exterior
D3 = Ø orificio
P = Altura de paso

DIMENSIONES DE ROSCA Y ORIFICIO / THREAD AND HOLE DIMENSIONS

Información técnica para montaje / Technical info for mounting

Rosca PG según DIN 40430

Tipo de rosca Thread type	Ø D1	P	Ø D2	Rosca / Thread Ø D3
PG 7	12.5	1.27	11.3	13.0 ± 0.2
PG 9	15.2	1.41	13.9	15.7 ± 0.2
PG 11	18.6	1.41	17.3	19.0 ± 0.2
PG 13.5	20.4	1.41	19.1	21.0 ± 0.2
PG 16	22.5	1.41	21.2	23.0 ± 0.2
PG 21	28.3	1.558	26.6	28.8 ± 0.2
PG 29	37.0	1.558	35.5	37.5 ± 0.3
PG 36	47.0	1.558	45.5	47.5 ± 0.3
PG 42	54.0	1.558	52.5	54.5 ± 0.3
PG 48	59.3	1.558	57.8	59.8 ± 0.3

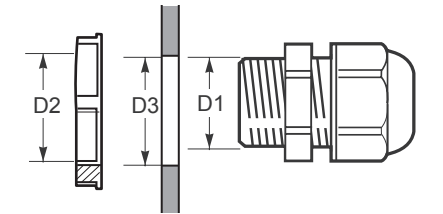

D1 = Ø central
D2 = Ø exterior
D3 = Ø orificio
P = Altura de paso



Protección contra agua y polvo
Protection against water and dust



Protección contra el impacto
Protection against impact



Libre de gases tóxicos
Free of toxic gases



Protección clase II (doble aislamiento eléctrico)
Class II protection (double electric isolation)



Protección contra la luz ultravioleta
UV Protection



Número de protecciones tipo Europeo
Number of MCB's, European type



Número de tomas interbloqueadas verticales
Number of vertical interlocked switched sockets



Número de tomas interbloqueadas horizontales
Number of horizontal interlocked switched sockets



Número de tomas de cuadro
Number of panel sockets



Test hilo incandescente a 650°
Glow wire test at 650°



Test hilo incandescente a 850°
Glow wire test at 850°



Test hilo incandescente a 850°
Glow wire test at 850°



Declaración de conformidad Europea
European Declaration of Conformity



Certificación ENEC
ENEC certification



Enrollables recogido
Rolled up cable reels



Enrollables extendido
Unrolled cable reels



Sistema Schuko
Schuko system



Sistema Schuko
Schuko system



Sistema Schuko Francés
French Schuko system



Sistema Schuko cuadro
Schuko panel socket



Packaging mínimo
Minimum carton box



Packaging master
Master box

CLAVIJAS, BASES, ADAPTADORES, ENROLLACABLES E INTERRUPTORES DE CORTE IP44 / IP67
PLUGS, SOCKETS, ADAPTATORS, CABLEREELS AND SAFETY SWITCHES IP44 / IP67

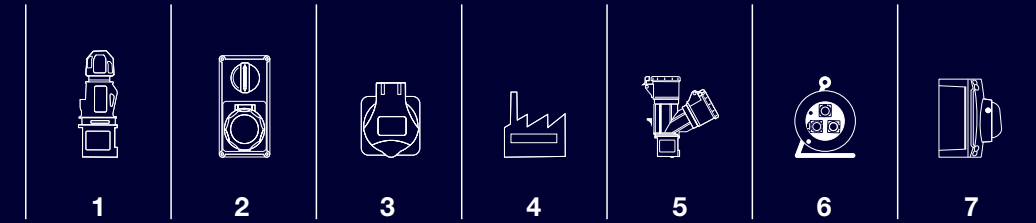

1 TOMAS Y CLAVIJAS INDUSTRIALES IP44 / IP67; 16A - 125A
INDUSTRIAL PLUGS AND SOCKETS IP44 / IP67; 16A - 125A

Ergonomía, Robustez, Seguridad, Rapidez de conexionado, Precisión.
La gama de clavijas y tomas industriales SpeedPRO es el resultado de la suma de todas estas propiedades.
Diseñadas y fabricadas de acuerdo con las más exigentes normativas de calidad, garantizan el mejor funcionamiento en condiciones extremas de temperatura, impacto y estanqueidad.

Ergonomics, Robustness, Safety, Quick connection, Accuracy.
The range of industrial plugs and sockets SpeedPRO is the result of the addition of all these properties.
Designed and manufactured according to the most demanding quality standards, they guarantee the best performance in extreme conditions of temperature, impact and watertightness.



“La seguridad en las instalaciones es mi prioridad”

“Safety on the installations is my priority”



AHORRA TIEMPO

- Optimo espacio para el cableado
- Contacto terminales abiertos
- Fácil, rápido y seguro sistema apertura/cierre

TIME SAVING

- Optimum space for cabling
- Open contact terminals
- Easy, quick and safe opening/closing



Proyecto subestación eléctrica.
Qatar QEWC
Electrical substation
Qatar project QEWC



Proyecto refinería Barrancabermeja.
Colombia
Refinery Barrancabermeja
Colombia project



Proyecto astilleros de Cádiz
Cádiz Shipyard project

ERGONOMÍA ÓPTIMA
OPTIMUM ERGONOMICS



Mejor sujeción y apertura de tapas en las tomas gracias a la ergonomía del diseño.

Better adhesion and opening of the socket covers, thanks to the design ergonomics.

PRECISIÓN
PRECISION

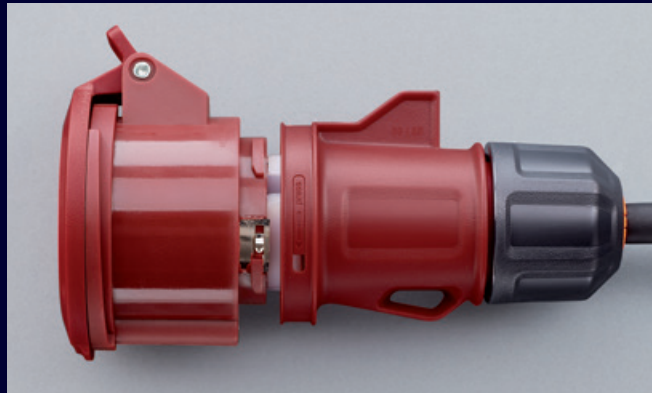

El sistema de seguridad con muelle de acero inoxidable garantiza la rapidez en las constantes aperturas y cierres.

The stainless steel spring safety system guarantees rapid opening and closing on a constant basis.

PRENSADO TIPO "TUERCA"
"NUT"-BASED PRESSING

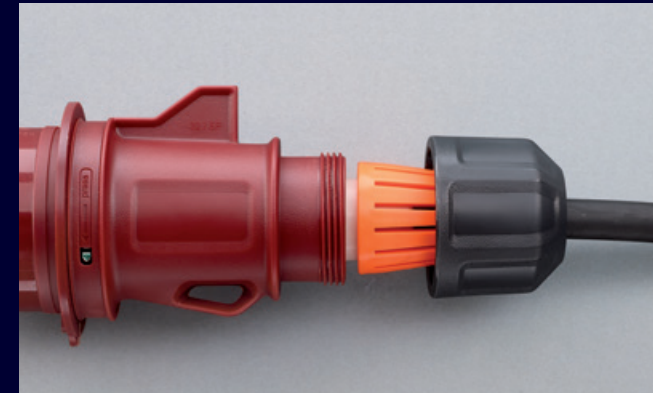

El sistema exclusivo de Famatel de prensado de cable tipo "tuerca", con antivibración, facilita el mantenimiento y la durabilidad del cable.

Famatel's exclusive "nut"-based anti-vibration pressing system, enables the maintenance and durability of the cable.

RESISTENCIA, SEGURIDAD, ROBUSTEZ
RESISTENCE, SAFETY AND ROBUSTNESS



Diseño funcional que garantiza los máximos índices de seguridad en todos los entornos y las mejores prestaciones gracias a su ergonomía.

A functional design that guarantees the highest levels of safety in all environments and top-level performance, thanks to its ergonomics.

CONEXIÓN POR TORNILLOS SpeedPRO Line
SCREW CONNECTION SpeedPRO LINE



En la gama SpeedPRO, todos los tornillos de conexión están orientados en la misma dirección evitando así tener que girar la pieza durante el proceso de cableado.

In the range SpeedPRO, all screws of the clamps are oriented in the same direction so that it is not necessary to turn the plugs or sockets during the cabling process.

CONEXIÓN RÁPIDA SIN TORNILLOS TOPSpeedPRO Line
SCREWLESS QUICK CONNECTION TOPSpeedPRO LINE



Las tomas industriales "TOP-Speed Pro" reúnen todas las propiedades de las anteriores pero sumando una mayor rapidez en el conexionado gracias a su conexión sin tornillo, para aquellos usuarios más exigentes con su tiempo. Hasta un 50% más rápido respecto al cableado con tornillo.

The "TOP-Speed Pro" industrial plugs and sockets combine all the properties of the previous ones but adding a faster connection thanks to its connection without screw, for those users more demanding with their time. Up to 50% faster than screw wiring.

FÁCIL INSTALACIÓN
EASY ASSEMBLY



Gracias a un colgador integrado en el cuerpo, el diseño permite fijar las tomas y bases en posiciones óptimas.

The design allows sockets and bases to be fitted in optimal locations, thanks to the built-in hanger in its body.

VERSATILIDAD
VERSATILITY



El diseño de las tomas y bases se adecuan a todo tipo de aplicaciones y de usos en ambientes extremos (humedad, polvo, aceite...).

Disponible en todas las posiciones horarias.

The design of the sockets and bases are suitable for all types of applications and uses in the most extreme environments (moisture, dust, oil, etc.).

Available in positions to suit all timetables.

1
Insertar cable en toma.

Insert the cable into the socket.

2
Conectar SpeedPRO.
Conectar y apretar los tornillos de los terminales.
Todos los tornillos de conexión están orientados en la misma dirección evitando así tener que girar la pieza durante el proceso de cableado.
Todos los tornillos se suministran desatornillados para agilizar el cableado.

Connect SpeedPRO.
Connect and tighten the terminal screws.
All the connection screws must be facing in the same direction, ensuring that the part does not have to be rotated during cabling.
All the screws are placed ready to be tightened in order to speed up cabling.

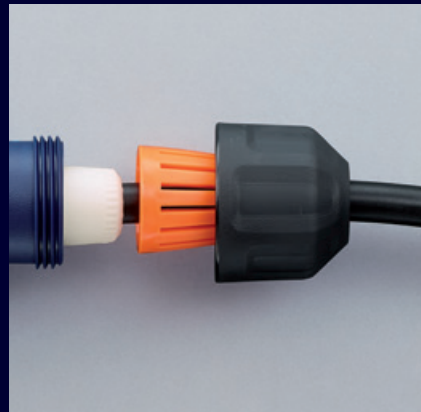

3
Ubicar y girar la guía hasta oír el click.

Locate and turn the guide until you hear click.

4
Apretar prensacable para evitar que el esfuerzo de tracción y torsión se transmita al final del conductor.

Tighten the cable gland to prevent the tensile and torsional stresses from being transmitted at the end of the conductor.



CLAVIJAS AÉREAS

MOBILE PLUGS

Pg. 23



BASES AÉREAS

MOBILE SOCKETS

Pg. 31



CLAVIJAS DE PARED
ACODADAS 90°

WALL MOUNTED PLUGS 90°

Pg. 25



BASES FIJAS DE PARED
ACODADAS 90°

WALL MOUNTED SOCKET 90°

Pg. 33



CLAVIJAS DE CUADRO
SALIDA RECTA

STRAIGHT PANEL PLUGS

Pg. 27



BASES CUADRO
SALIDA RECTA

STRAIGHT PANEL SOCKETS

Pg. 35



BASES CUADRO
INCLINADAS

ANGLED PANEL SOCKETS

Pg. 37



CLAVIJAS DE PARED

WALL MOUNTED PLUGS

Pg. 29



BASES DE PARED

WALL MOUNTING SOCKETS

Pg. 39



CAJAS VACÍAS

EMPTY BOXES

Pg. 43



CLAVIJAS AEREAS / MOBILE PLUGS

SpeedPRO IP44
clavija aérea / mobile plug

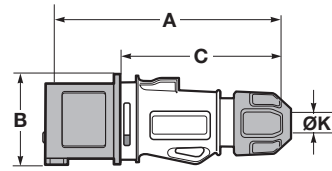

Poles	16A			32A		
	3	4	5	3	4	5
A	150	150	150	172	172	172
B	56	60	73	73	73	79
C	110	110	110	125	125	125
Ø K	6-15	6-15	8-16	11,5-21	11,5-21	11,5-21
Connection type	Conexión por tornillo / Screw terminals					
Wire flexible (mm ²)	1 - 2,5			2,5 - 6		
Weight (g)	123	139	157	220	239	262

- Terminales con tornillo
- Material: PA6/ABS
- Contactos: Latón
- IP44 a prueba de salpicaduras
- With screw terminals
- Housing material: PA6/ABS
- Contacts: Brass
- IP44 Splashproof

SpeedPRO IP67
clavija aérea / mobile plug

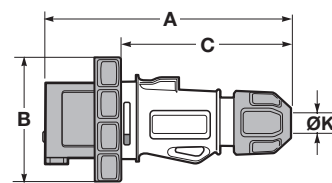

Poles	16A			32A		
	3	4	5	3	4	5
A	150	150	150	172	172	172
B	70	70	70	73	73	73
C	110	110	110	125	125	125
Ø K	6-15	6-15	8-16	11,5-21	11,5-21	11,5-21
Connection type	Conexión por tornillo / Screw terminals					
Wire flexible (mm ²)	1 - 2,5			2,5 - 6		
Weight (g)	142	158	173	232	250	273

- Terminales con tornillo
- Material: PA6/ABS
- Contactos: Latón
- IP67 Hermético
- With screw terminals
- Housing material: PA6/ABS
- Contacts: Brass
- IP67 Watertight

SpeedPRO IP67
clavija aérea / mobile plug

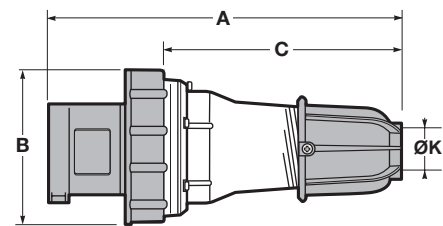

Poles	63A		
	3	4	5
A	260	260	260
B	114	75	75
C	175	175	175
Ø K	14,5 - 34	14,5 - 34	14,5 - 34
Connection type	Conexión por tornillo / Screw terminals		
Wire flexible (mm ²)	6 - 16		
Weight (g)	585	600	620

- Terminales con tornillo allen
- Material: PA6/ABS
- Contactos: Latón con contacto piloto
- IP67 Hermético
- With screw terminals allen
- Housing material: PA6/ABS
- Contacts: Brass with pilot contact
- IP67 Watertight

SpeedPRO IP67
clavija aérea / mobile plug

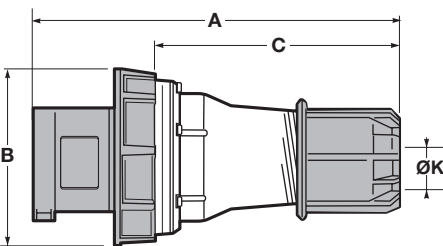

Poles	125A		
	3	4	5
A	270	270	270
B	131	131	131
C	190	190	190
Ø K	22,5 - 50	22,5 - 50	22,5 - 50
Connection type	Conexión por tornillo / Screw terminals		
Wire flexible (mm ²)	16 - 50		
Weight (g)	960	1065	1169

- Terminales con tornillo allen
- Material: PA6
- Contactos: Contacto niquelado con contacto piloto
- IP67 Hermético
- With screw terminals allen
- Housing material: PA6
- Contacts: Nickel-plated with pilot contact
- IP67 Watertight

3P = 2P + T
4P = 3P + T
5P = 3P + T + N

110V
50/60Hz

230V
50/60Hz

400V
50/60Hz

500V
50/60Hz

Amp	Poles	Pack unit	110V 50/60Hz	230V 50/60Hz	400V 50/60Hz	500V 50/60Hz
			Poles: 3P 4P 5P Hour P: 4h 4h 4h	Poles: 3P 4P 5P Hour P: 6h 9h 9h	Poles: 3P 4P 5P Hour P: 9h 6h 6h	Poles: 3P 4P 5P Hour P: 7h 7h 7h

16	3	10	13100	13200	13304	13404
	4	10	13101	13201	13300	13400
	5	8	13104	13202	13301	13401
32	3	5	13102	13203	13305	13405
	4	5	13103	13204	13302	13402
	5	4	13105	13206	13303	13403



Ref. / Item 13200



16	3	10	14100	14200	14309	14408
	4	8	14101	14201	14300	14400
	5	6	14112	14202	14301	14401
32	3	4	14102	14203	14310	14409
	4	4	14103	14204	14302	14402
	5	3	14113	14210	14303	14403



Ref. / Item 14303



63	3	10	9155	9159	14311	14410
	4	10	9156	9160	14304	14404
	5	10	14114	14209	14305	14405



Ref. / Item 14304



125	3	2	043-4	043-6	14312	14411
	4	2	14111	14208	14306	14406
	5	2	14115	14211	14307	14407



Ref. / Item 14306



1.1 CONEXIÓN POR TORNILLOS SpeedPro
SCREW CONNECTION SpeedPro

CLAVIJAS DE PARED ACODADAS 90° / WALL MOUNTED PLUGS 90°

SpeedPRO IP44
clavija de pared acodada 90° / wall mounted plug 90°

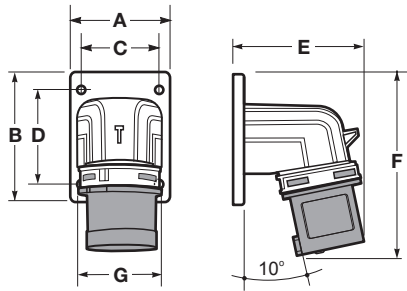

Poles	16A			32A		
	3	4	5	3	4	5
A	66	66	66	90	90	90
B	86	86	86	100	100	100
C	52	52	52	77	77	77
D	61	61	61	85	85	85
E	95	95	95	96	96	96
F	120	120	120	160	160	160
G	56	60	73	73	73	79
Connection type	Conexión por tornillo / Screw terminals					
Wire flexible (mm ²)	1 - 2,5			2,5 - 6		
Weight (g)	127	147	167	230	250	273

- Terminales con tornillo
- Material: PA6/ABS
- Contactos: Latón
- IP44 a prueba de salpicaduras
- With screw terminals
- Housing material: PA6/ABS
- Contacts: Brass
- IP44 Splashproof

3P = 2P + T
4P = 3P + T
5P = 3P + T + N

110V
50/60Hz

230V
50/60Hz

400V
50/60Hz

500V
50/60Hz

Amp	Poles	Pack unit	Poles: 3P 4P 5P Hour P: 4h 4h 4h	Poles: 3P 4P 5P Hour P: 6h 9h 9h	Poles: 3P 4P 5P Hour P: 9h 6h 6h	Poles: 3P 4P 5P Hour P: 7h 7h 7h
-----	-------	-----------	-------------------------------------	-------------------------------------	-------------------------------------	-------------------------------------

16	3	4	13150	13250	13354	13454
	4	4	13151	13251	13350	13450
	5	4	13154	13252	13351	13451
32	3	2	13152	13253	13355	13455
	4	2	13153	13254	13352	13452
	5	2	13155	13255	13353	13453

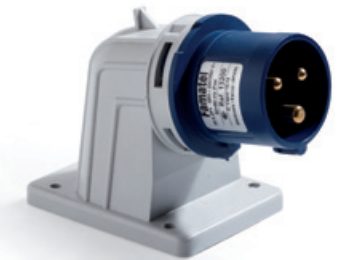

Ref. / Item 13250



SpeedPRO IP67
clavija de pared acodada 90° / wall mounted plug 90°

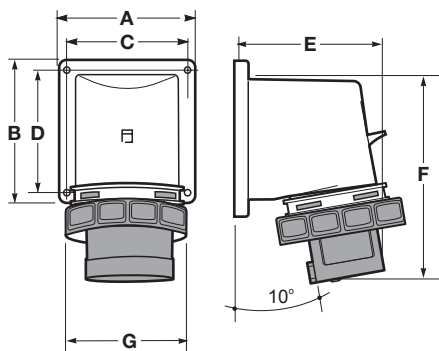

Poles	16A			32A		
	3	4	5	3	4	5
A	66	66	66	90	90	90
B	86	86	86	100	100	100
C	52	52	52	77	77	77
D	61	61	61	85	85	85
E	95	95	95	96	96	96
F	120	120	120	160	160	160
G	70	77	93	93	93	99
Connection type	Conexión por tornillo / Screw terminals					
Wire flexible (mm ²)	1 - 2,5			2,5 - 6		
Weight (g)	167	187	207	265	285	307

- Terminales con tornillo
- Material: PA6/ABS
- Contactos: Latón
- IP67 Hermético
- With screw terminals
- Housing material: PA6/ABS
- Contacts: Brass
- IP44 Watertight

16	3	4	14150	14250	14363	14456
	4	4	14151	14251	14350	14450
	5	4	14159	14252	14351	14451
32	3	2	14152	14253	14364	14457
	4	2	14153	14254	14352	14452
	5	2	14160	14259	14353	14453



Ref. / Item 14353



1.1 CONEXIÓN POR TORNILLOS SpeedPro
SCREW CONNECTION SpeedPro

CLAVIJAS DE CUADRO SALIDA RECTA / STRAIGHT PANEL PLUGS

SpeedPRO IP44 75x75 16A / 75x85 32A
clavija de cuadro / straight panel plug

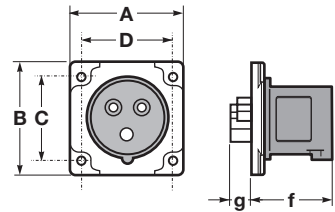

Poles	16A			32A		
	3	4	5	3	4	5
A	75	75	75	75	75	75
B	75	75	75	85	85	85
C	60	60	60	60	60	60
D	60	60	60	60	60	60
f	48	48	48	57	57	57
g	15	15	15	18	18	18
Connection type	Conexión por tornillo / Screw terminals					
Wire flexible (mm²)	1 - 2,5			2,5 - 6		
Weight (g)	89	109	124	131	151	174

- Terminales con tornillo
- Material: PA6/ABS
- Contactos: Latón
- IP44 a prueba de salpicaduras
- With screw terminals
- Housing material: PA6/ABS
- Contacts: Brass
- IP44 Splashproof

SpeedPRO IP44 55x55
clavija de cuadro / straight panel plug

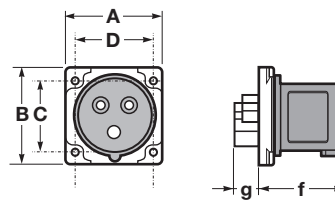

Poles	16A		
	3	4	5
A	55	55	55
B	55	55	55
C	44	44	44
D	44	44	44
f	48	48	48
g	15	15	15
Connection type	Conexión por tornillo / Screw terminals		
Wire flexible (mm²)	1 - 2,5		
Weight (g)	89	109	124

- Terminales con tornillo
- Material: PA6/ABS
- Contactos: Latón
- IP44 a prueba de salpicaduras
- With screw terminals
- Housing material: PA6/ABS
- Contacts: Brass
- IP44 Splashproof

SpeedPRO IP44 75x85
clavija de cuadro / straight panel plug

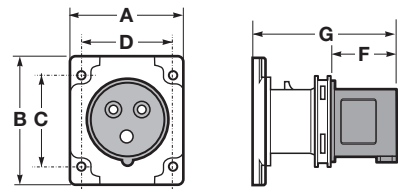

Poles	16A		
	3	4	5
A	75	75	75
B	85	85	85
C	60	60	60
D	60	60	60
F	39	39	39
G	99	99	99
Connection type	Conexión por tornillo / Screw terminals		
Wire flexible (mm²)	1 - 2,5		
Weight (g)	89	109	124

- Terminales con tornillo
- Material: PA6/ABS
- Contactos: Latón
- IP44 a prueba de salpicaduras
- With screw terminals
- Housing material: PA6/ABS
- Contacts: Brass
- IP44 Splashproof

SpeedPRO IP67 75x85
clavija de cuadro / straight panel plug

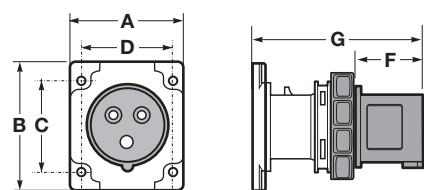

Poles	16A		
	3	4	5
A	75	75	75
B	85	85	85
C	60	60	60
D	60	60	60
F	39	39	39
G	99	99	99
Connection type	Conexión por tornillo / Screw terminals		
Wire flexible (mm²)	1 - 2,5		
Weight (g)	89	109	124

- Terminales con tornillo
- Material: PA6/ABS
- Contactos: Latón
- IP67 Hermético
- With screw terminals
- Housing material: PA6/ABS
- Contacts: Brass
- IP67 Watertight

3P = 2P + T
4P = 3P + T
5P = 3P + T + N

110V	230V	400V	500V
50/60Hz	50/60Hz	50/60Hz	50/60Hz

Amp	Poles	Pack unit	Poles: 3P 4P 5P Hour P: 4h 4h 4h	Poles: 3P 4P 5P Hour P: 6h 9h 9h	Poles: 3P 4P 5P Hour P: 9h 6h 6h	Poles: 3P 4P 5P Hour P: 7h 7h 7h
-----	-------	-----------	-------------------------------------	-------------------------------------	-------------------------------------	-------------------------------------

16	3	10	1110	1107A	13374	13837
	4	10	1111	1114	1116	13831
	5	8	13537	13636	1117	13832
32	3	5	1112	1108A	13375	13838
	4	5	1113	1115	1118	13833
	5	5	13538	13637	1109A	13834



Ref. / Item 13631



SpeedPRO IP44 55x55
clavija de cuadro / straight panel plug

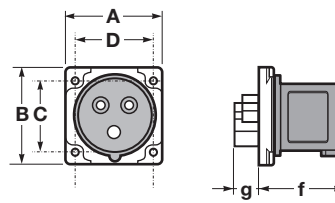

Poles	16A		
	3	4	5
A	55	55	55
B	55	55	55
C	44	44	44
D	44	44	44
f	48	48	48
g	15	15	15
Connection type	Conexión por tornillo / Screw terminals		
Wire flexible (mm²)	1 - 2,5		
Weight (g)	89	109	124

- Terminales con tornillo
- Material: PA6/ABS
- Contactos: Latón
- IP44 a prueba de salpicaduras
- With screw terminals
- Housing material: PA6/ABS
- Contacts: Brass
- IP44 Splashproof

16	3	10	13535	13634	13733	13839
	4	10	13536	13635	13731	13835
	5	10	13539	13638	13732	13836



Ref. / Item 13634



SpeedPRO IP44 75x85
clavija de cuadro / straight panel plug

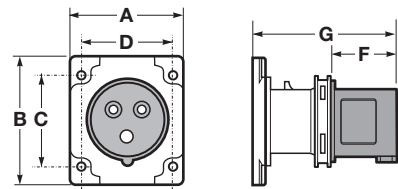

Poles	16A		
	3	4	5
A	75	75	75
B	85	85	85
C	60	60	60
D	60	60	60
F	39	39	39
G	99	99	99
Connection type	Conexión por tornillo / Screw terminals		
Wire flexible (mm²)	1 - 2,5		
Weight (g)	89	109	124

- Terminales con tornillo
- Material: PA6/ABS
- Contactos: Latón
- IP44 a prueba de salpicaduras
- With screw terminals
- Housing material: PA6/ABS
- Contacts: Brass
- IP44 Splashproof

16	3	4	13541	13641	13743	13483
	4	4	13542	13642	13741	13841
	5	4	13543	13643	13742	13842



Ref. / Item 13641



SpeedPRO IP67 75x85
clavija de cuadro / straight panel plug

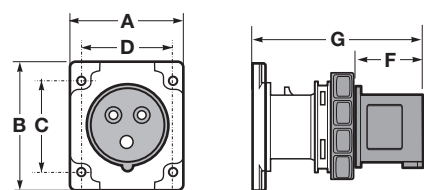

Poles	16A		
	3	4	5
A	75	75	75
B	85	85	85
C	60	60	60
D	60	60	60
F	39	39	39
G	99	99	99
Connection type	Conexión por tornillo / Screw terminals		
Wire flexible (mm²)	1 - 2,5		
Weight (g)	89	109	124

- Terminales con tornillo
- Material: PA6/ABS
- Contactos: Latón
- IP67 Hermético
- With screw terminals
- Housing material: PA6/ABS
- Contacts: Brass
- IP67 Watertight

16	3	4	14541	1160	1162	14843
	4	4	14542	1161	14741	14841
	5	4	14543	14643	14742	14842



Ref. / Item 14742



CLAVIJAS DE PARED / WALL MOUNTED PLUGS

SpeedPRO IP44
clavija de pared / wall mounted plug

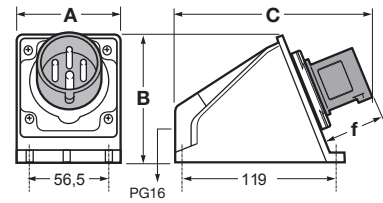

Poles	16A			32A		
	3	4	5	3	4	5
A	81	81	61	81	81	81
B	97	97	97	97	97	97
C	151	151	151	151	151	151
f	48	48	48	57	57	57
Connection type	Conexión por tornillo / Screw terminals					
Wire flexible (mm²)	1 - 2,5			2,5 - 6		
Weight (g)	226	244	260	271	290	314

- Terminales con tornillo
- Material: PA6/ABS
- Contactos: Latón
- Entrada trasera

IP44 a prueba de salpicaduras

- With screw terminals
- Housing material: PA6/ABS
- Contacts: Brass
- Rear entry

IP44 Splashproof

SpeedPRO IP67
clavija de pared / wall mounted plug

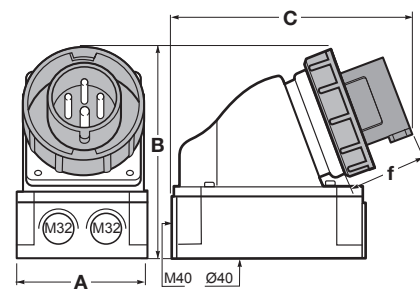

Poles	63A		
	3	4	5
A	118	118	118
B	190	190	190
C	220	220	220
f	82	82	82
Connection type	Conexión por tornillo / Screw terminals		
Wire flexible (mm²)	6 - 16		
Weight (g)	840	850	860

- Terminales con tornillo allen
- Material: PA6/ABS
- Contactos: Latón con contacto piloto
- Entradas superiores, inferiores y traseras.
- El conjunto de la toma puede montarse simétricamente a 180° sobre su base

IP67 Hermético

- With screw terminals allen
- Housing material: PA6/ABS
- Contacts: Brass with pilot contact
- Top, 2 x Bottom and rear entry
- Housing can be rotated by 180°

IP67 Watertight

SpeedPRO IP67
clavija de pared / wall mounted plug

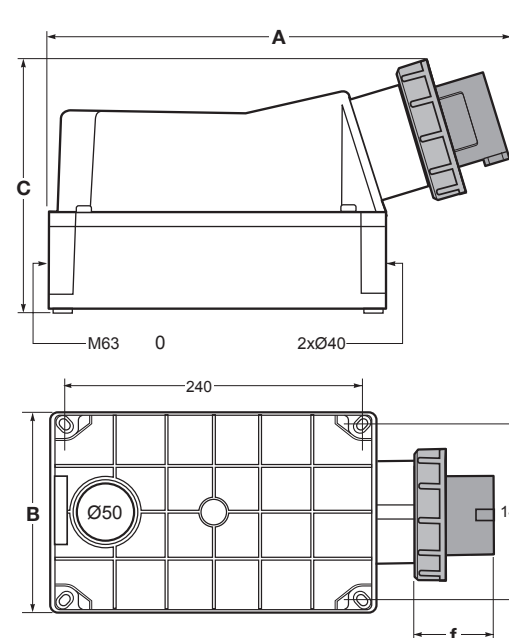

Poles	125A		
	3	4	5
A	387	75	75
B	162	85	85
C	220	60	60
D	60	60	60
f	60	60	80
Connection type	Conexión por tornillo / Screw terminals		
Wire flexible (mm²)	16 - 50		
Weight (g)	1620	1725	1834

- Terminales con tornillos allen
- Material: PA6/ABS
- Contactos: Niquelados con contacto piloto
- Entradas superiores, inferiores y traseras
- El conjunto de la toma puede montarse simétricamente a 180° sobre su base

IP67 Hermético

- With Screw terminals allen
- Housing material: PA6/ABS
- Contacts: Nickel-plated contacts with pilot contact
- Top, Bottom and rear entry
- Housing can be rotated by 180°

IP67 Watertight

3P = 2P + T
4P = 3P + T
5P = 3P + T + N

110V
50/60Hz

230V
50/60Hz

400V
50/60Hz

500V
50/60Hz

Amp	Poles	Pack unit	Poles: 3P 4P 5P Hour P: 4h 4h 4h	Poles: 3P 4P 5P Hour P: 6h 9h 9h	Poles: 3P 4P 5P Hour P: 9h 6h 6h	Poles: 3P 4P 5P Hour P: 7h 7h 7h
-----	-------	-----------	-------------------------------------	-------------------------------------	-------------------------------------	-------------------------------------

16	3	3	1123	1127	13765	13865
	4	3	1124	1128	1131	13861
	5	3	13505	13665	1132	13862
32	3	2	1112	1129	13766	13866
	4	2	1126	13664	1133	13863
	5	2	13506	13666	1134	13864



Ref. / Item 13764



Ref. / Item 14355



Ref. / Item 14381



BASES AEREAS / MOBILE SOCKETS

SpeedPRO IP44
base aérea / mobile socket

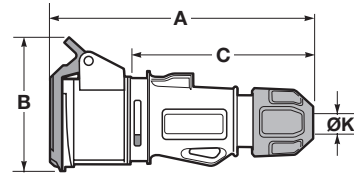

Poles	16A			32A		
	3	4	5	3	4	5
A	157	157	150	178	178	178
B	85	91	97	105	105	102
C	110	110	110	125	125	125
Ø K	6-15	6-15	8-16	11,5-21	11,5-21	11,5-21
Connection type	Conexión por tornillo / Screw terminals					
Wire flexible (mm²)	1 - 2,5			2,5 - 6		
Weight (g)	215	230	252	275	285	318

- Terminales con tornillo
- Material: PA6/ABS
- Contactos: Niquelados
- IP44 a prueba de salpicaduras
- With screw terminals
- Housing material: PA6/ABS
- Contacts: Nickel-plated contacts
- IP44 Splashproof

SpeedPRO IP67
base aérea / mobile socket

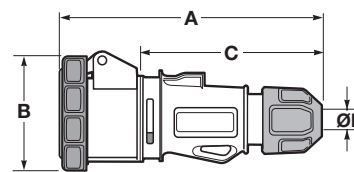

Poles	16A			32A		
	3	4	5	3	4	5
A	165	157	157	170	170	170
B	80	91	60	76	76	118
C	110	110	110	125	125	125
Ø K	6-15	6-15	6-15	11,5-21	11,5-21	11,5-21
Connection type	Conexión por tornillo / Screw terminals					
Wire flexible (mm²)	1 - 2,5			2,5 - 6		
Weight (g)	185	205	215	305	315	325

- Terminales con tornillo
- Material: PA6/ABS
- Contactos: Niquelados
- IP67 Hermético
- With screw terminals
- Housing material: PA6/ABS
- Contacts: Nickel-plated contacts
- IP67 Watertight

SpeedPRO IP67
base aérea / mobile socket

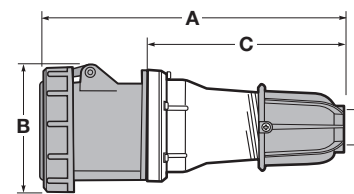

Poles	63A		
	3	4	5
A	260	260	260
B	110	110	110
C	175	175	175
Ø K	14,5 - 34	14,5 - 34	14,5 - 34
Connection type	Conexión por tornillo / Screw terminals		
Wire flexible (mm²)	6 - 16		
Weight (g)	705	725	750

- Terminales con tornillo allen
- Material: PA6/ABS
- Contactos: Latón
- Para pedir con contacto piloto añadir una *P, ej. 24304P
- IP67 Hermético
- With screw terminals allen
- Housing material: PA6/ABS
- Contacts: Brass
- To order with Pilot contact add please a *P, eg. 24304P
- IP67 Watertight

SpeedPRO IP67
base aérea / mobile socket

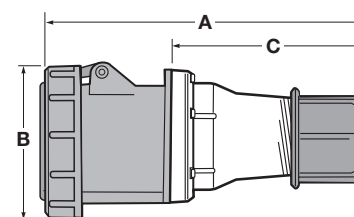

Poles	125A		
	3	4	5
A	270	270	270
B	130	130	130
C	175	175	175
Ø K	22,5 - 50	22,5 - 50	22,5 - 50
Connection type	Conexión por tornillo / Screw terminals		
Wire flexible (mm²)	16 - 50		
Weight (g)	1029	1072	1145

- Terminales con tornillo allen
- Material: PA6
- Contactos: Latón
- Para pedir con contacto piloto añadir una *P, ej. 24306P
- IP67 Hermético
- With screw terminals allen
- Housing material: PA6
- Contacts: Brass
- To order with Pilot contact add please a *P, eg. 24306P
- IP67 Watertight

3P = 2P + T
4P = 3P + T
5P = 3P + T + N

110V
50/60Hz

230V
50/60Hz

400V
50/60Hz

500V
50/60Hz

Amp	Poles	Pack unit	110V 50/60Hz	230V 50/60Hz	400V 50/60Hz	500V 50/60Hz
			Poles: 3P 4P 5P Hour P: 4h 4h 4h	Poles: 3P 4P 5P Hour P: 6h 9h 9h	Poles: 3P 4P 5P Hour P: 9h 6h 6h	Poles: 3P 4P 5P Hour P: 7h 7h 7h

16	3	10	23100	23200	23304	23404
	4	10	23101	23201	23300	23400
	5	5	23104	23202	23301	23401
32	3	4	23102	23203	23305	23405
	4	4	23103	23204	23302	23402
	5	3	23105	23205	23303	23403



Ref. / Item 23200



16	3	10	24100	24200	24310	24410
	4	6	24101	24201	24300	24400
	5	4	24107	24202	24301	24401
32	3	3	24102	24203	24311	24411
	4	3	24103	24204	24302	24402
	5	3	24112	24210	24303	24403



Ref. / Item 24303



63	3	10	9055	9059	24312	24412
	4	10	9056	9060	24304	24404
	5	10	24113	24209	24305	24405



Ref. / Item 24305



125	3	2	243-4	243-6	24313	24413
	4	2	24111	24208	24306	24406
	5	2	24114	24211	24307	24407



Ref. / Item 24306



1.1 CONEXIÓN POR TORNILLOS SpeedPro
SCREW CONNECTION SpeedPro

BASES FIJAS PARED ACODADAS 90° / WALL MOUNTED SOCKET 90°

SpeedPRO IP44
base de pared acodada 90° / wall mounted socket 90°

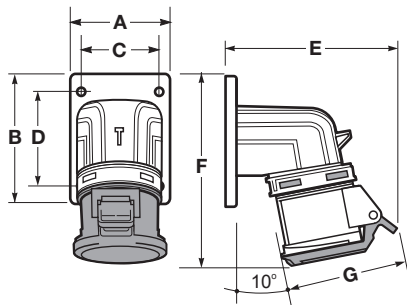

Poles	16A			32A		
	3	4	5	3	4	5
A	66	66	66	90	90	90
B	86	86	100	100	100	100
C	52	52	77	77	77	77
D	61	61	85	85	85	85
E	95	120	96	140	96	143
F	126	126	136	160	160	160
G	86	94	102	108	108	113
Connection type	Conexión por tornillo / Screw terminals					
Wire flexible (mm ²)	1 - 2,5			2,5 - 6		
Weight (g)	172	182	241	290	296	332

- Terminales con tornillo
 - Material: PA6/ABS
 - Contactos: Niquelados
- IP44** a prueba de salpicaduras
- With screw terminals
 - Housing material: PA6/ABS
 - Contacts: Nickel-plated contacts
- IP44** Splashproof

3P = 2P + T
4P = 3P + T
5P = 3P + T + N

110V
50/60Hz

230V
50/60Hz

400V
50/60Hz

500V
50/60Hz

Amp	Poles	Pack unit	Poles: 3P 4P 5P Hour P: 4h 4h 4h	Poles: 3P 4P 5P Hour P: 6h 9h 9h	Poles: 3P 4P 5P Hour P: 9h 6h 6h	Poles: 3P 4P 5P Hour P: 7h 7h 7h
-----	-------	-----------	-------------------------------------	-------------------------------------	-------------------------------------	-------------------------------------

16	3	4	23150	23250	23354	23454
	4	4	23151	23251	23350	23450
	5	2	23154	23252	23351	23451
32	3	2	23152	23253	23355	23455
	4	2	23153	23254	23352	23452
	5	2	23155	23255	23353	23453



Ref. / Item 23250



SpeedPRO IP67
base de pared acodada 90° / wall mounted socket 90°

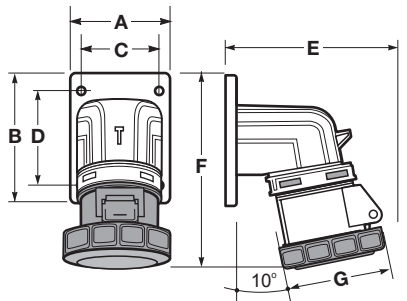

Poles	16A			32A		
	3	4	5	3	4	5
A	66	66	90	90	90	90
B	86	86	100	100	100	100
C	52	52	77	77	77	77
D	61	61	85	85	85	85
E	95	120	96	140	96	143
F	126	126	136	160	160	160
G	70	78	85	92	92	99,5
Connection type	Conexión por tornillo / Screw terminals					
Wire flexible (mm ²)	1 - 2,5			2,5 - 6		
Weight (g)	135	215	241	290	296	332

- Terminales con tornillo
 - Material: PA6/ABS
 - Contactos: Niquelados
- IP67** Hermético
- With screw terminals
 - Housing material: PA6/ABS
 - Contacts: Nickel-plated contacts
- IP67** Watertight

16	3	4	24150	24250	24354	24454
	4	4	24151	24251	24350	24450
	5	2	24154	24252	24351	24451
32	3	2	24152	24253	24355	24455
	4	2	24153	24254	24352	24452
	5	2	24155	24255	24353	24453



Ref. / Item 24353



1.1 CONEXIÓN POR TORNILLOS SpeedPro
SCREW CONNECTION SpeedPro

BASES CUADRO SALIDA RECTA / STRAIGHT PANEL SOCKETS

SpeedPRO IP44
base de cuadro / straight panel socket

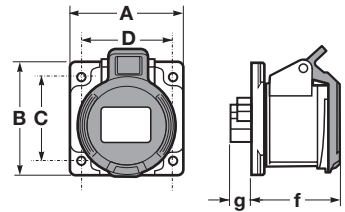

Poles	16A			32A		
	3	4	5	3	4	5
A	75	75	75	75	75	75
B	75	75	85	85	85	85
C	60	60	60	60	60	60
D	60	60	60	60	60	60
f	55	48	58	67	67	67
g	15	15	15	20	20	20
Connection type	Conexión por tornillo / Screw terminals					
Wire flexible (mm²)	1 - 2,5			2,5 - 6		
Weight (g)	138	152	175	203	210	245

- Terminales con tornillo
- Material: PA6/ABS
- Contactos: Niquelados
- IP44 a prueba de salpicaduras
- With screw terminals
- Housing material: PA6/ABS
- Contacts: Nickel-plated contacts
- IP44 Splashproof

SpeedPRO IP67
base de cuadro / straight panel socket

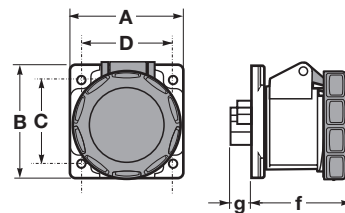

Poles	16A			32A		
	3	4	5	3	4	5
A	75	75	75	75	75	75
B	75	75	85	85	85	85
C	60	60	60	60	60	60
D	60	60	60	60	60	60
f	62	62	65	72	72	72
g	15	15	15	20	20	20
Connection type	Conexión por tornillo / Screw terminals					
Wire flexible (mm²)	1 - 2,5			2,5 - 6		
Weight (g)	156	170	192	227	234	270

- Terminales con tornillo
- Material: PA6/ABS
- Contactos: Niquelados
- IP67 Hermético
- With screw terminals
- Housing material: PA6/ABS
- Contacts: Nickel-plated contacts
- IP67 Watertight

SpeedPRO IP67
base de cuadro / straight panel socket

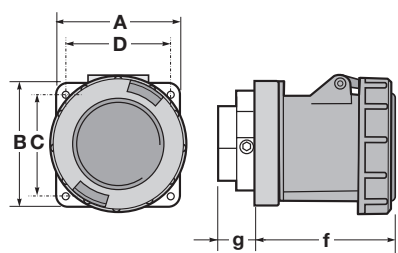

Poles	63A		
	3	4	5
A	100	100	100
B	100	100	100
C	80	80	80
D	80	80	80
f	100	100	100
g	28	28	28
Connection type	Conexión por tornillo / Screw terminals		
Wire flexible (mm²)	6 - 16		
Weight (g)	615	628	635

- Terminales con tornillo allen
- Material: PA6/ABS
- Contactos: Latón
- Para pedir con contacto piloto añadir una *P, ej. 24374P
- Posibilidad de montar en armarios Aqua Combi haciendo uso de la placa adaptadora ref. 3909
- IP67 Hermético
- With screw terminals allen
- Housing material: PA6/ABS
- Contacts: Brass
- To order with Pilot contact add please a *P, eg. 24374P
- Possibility to mount in Aqua combi enclosures using the adaptor plate ref. 3909
- IP67 Watertight

SpeedPRO IP67
base de cuadro / straight panel socket

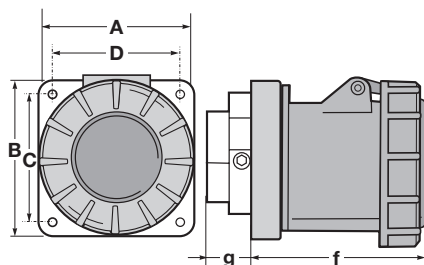

Poles	125A		
	3	4	5
A	120	120	120
B	120	120	120
C	100	100	100
D	100	100	100
f	101	101	101
g	48	48	48
Connection type	Conexión por tornillo / Screw terminals		
Wire flexible (mm²)	16 - 50		
Weight (g)	752	890	986

- Terminales con tornillo allen
- Material: PA6
- Contactos: Latón
- Para pedir con contacto piloto añadir una *P, ej. 24376P
- IP67 Hermético
- With screw terminals allen
- Housing material: PA6
- Contacts: Brass
- To order with Pilot contact add please a *P, eg. 24376P
- IP67 Watertight

3P = 2P + T
4P = 3P + T
5P = 3P + T + N

110V	230V	400V	500V
50/60Hz	50/60Hz	50/60Hz	50/60Hz

Amp	Poles	Pack unit	110V	230V	400V	500V
			Poles: 3P 4P 5P Hour P: 4h 4h 4h	Poles: 3P 4P 5P Hour P: 6h 9h 9h	Poles: 3P 4P 5P Hour P: 9h 6h 6h	Poles: 3P 4P 5P Hour P: 7h 7h 7h

16	3	10	23170	23270	23374	23474
	4	10	23171	23271	23370	23470
	5	8	23174	23272	23371	23471
32	3	5	23172	23273	23375	23475
	4	5	23173	23274	23372	23472
	5	5	23175	23275	23373	23473



Ref. / Item 23270



16	3	8	24170	24270	24378	24474
	4	8	24171	24271	24370	24470
	5	8	24175	24272	24371	24471
32	3	5	24172	24273	24379	24475
	4	5	24173	24275	24372	24472
	5	5	24176	24279	24373	24473



Ref. / Item 24373



63	3	10	1359	1363	24380	24480
	4	10	24181	24281	24374	24481
	5	10	24182	24282	24375	24482



Ref. / Item 24374



125	3	2	343-4	343-6	24381	24483
	4	2	24184	24284	344-6	24484
	5	2	24185	24285	345-6	24485



Ref. / Item 24377



1.1 CONEXIÓN POR TORNILLOS SpeedPro
SCREW CONNECTION SpeedPro

BASES DE CUADRO INCLINADAS / ANGLED PANEL SOCKETS

SpeedPRO IP44 75x85 16A / 80x95 32A
base de cuadro inclinada 10° / angled panel socket 10°

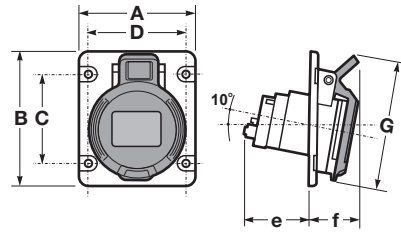

Poles	16A			32A		
	3	4	5	3	4	5
A	75	75	75	80	80	80
B	85	85	85	95	95	95
C	60	60	60	70	70	70
D	60	60	60	60	60	60
e	45	45	45	60	60	60
f	26	34	37	40	40	40
G	86	94	102	108	108	108
Connection type	Conexión por tornillo / Screw terminals					
Wire flexible (mm²)	1 - 2,5			2,5 - 6		
Weight (g)	122	132	157	185	195	215

- Terminales con tornillo
- Material: PA6/ABS
- Contactos: Niquelados
- IP44 a prueba de salpicaduras
- With screw terminals
- Housing material: PA6/ABS
- Contacts: Nickel-plated contacts
- IP44 Splashproof

3P = 2P + T
4P = 3P + T
5P = 3P + T + N

110V	230V	400V	500V
50/60Hz	50/60Hz	50/60Hz	50/60Hz

Amp	Poles	Pack unit	Poles: 3P 4P 5P Hour P: 4h 4h 4h	Poles: 3P 4P 5P Hour P: 6h 9h 9h	Poles: 3P 4P 5P Hour P: 9h 6h 6h	Poles: 3P 4P 5P Hour P: 7h 7h 7h
-----	-------	-----------	-------------------------------------	-------------------------------------	-------------------------------------	-------------------------------------

16	3	10	23130	23230	23334	23434
	4	10	23131	23231	23330	23430
	5	8	23134	23232	23331	23431
32	3	5	23132	23233	23335	23435
	4	5	23133	23234	23332	23432
	5	5	23135	23235	23333	23433



Ref. / Item 23230



SpeedPRO IP67 75x85 16A / 80x95 32A
base de cuadro inclinada 10° / angled panel socket 10°

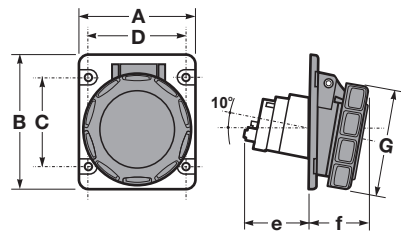

Poles	16A			32A		
	3	4	5	3	4	5
A	75	75	75	80	80	80
B	85	85	85	95	95	95
C	60	60	60	70	70	70
D	60	60	60	60	60	60
e	45	45	45	60	60	60
f	26	34	37	40	40	40
G	70	78	85	92	92	99,5
Connection type	Conexión por tornillo / Screw terminals					
Wire flexible (mm²)	1 - 2,5			2,5 - 6		
Weight (g)	135	145	165	200	215	245

- Terminales con tornillo
- Material: PA6/ABS
- Contactos: Niquelados
- IP67 Hermético
- With screw terminals
- Housing material: PA6/ABS
- Contacts: Nickel-plated contacts
- IP67 Watertight

16	3	10	24130	24230	24334	24434
	4	8	24131	24231	24330	24430
	5	8	24134	24232	24331	24431
32	3	5	24132	24233	24331	24441
	4	5	24133	24234	24332	24432
	5	5	24135	24240	24333	24433



Ref. / Item 24331



SpeedPRO IP67
base de cuadro inclinada 10° / angled panel socket 10°

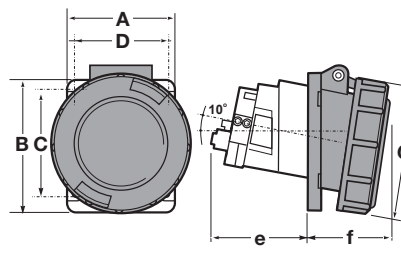

Poles	63A		
	3	4	5
A	85	85	85
B	100	100	100
C	72	72	72
D	72	72	72
e	83	83	83
f	58	58	58
G	110	110	110
Connection type	Conexión por tornillo / Screw terminals		
Wire flexible (mm²)	6 - 16		
Weight (g)	495	725	552

- Terminales con tornillo allen
- Material: PA6/ABS
- Contactos: Latón
- Para pedir con contacto piloto añadir una *P, ej. 24334P
- IP67 Hermético
- With screw terminals allen
- Housing material: PA6/ABS
- Contacts: Brass
- To order with Pilot contact add please a *P, eg. 24334P
- IP67 Watertight

63	3	10	24137	24235	24336	24442
	4	10	24138	24236	24334	24437
	5	10	24141	24238	24335	24438



Ref. / Item 24335



SpeedPRO IP67
base de cuadro inclinada 15° / angled panel socket 15°

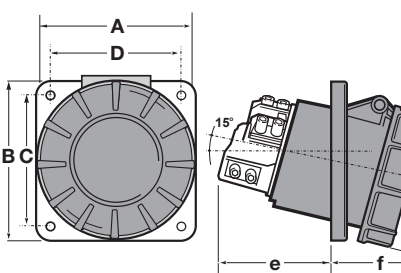

Poles	125A		
	3	4	5
A	120	120	120
B	130	130	130
C	100	100	100
D	108	108	108
e	92	92	92
f	77	77	77
G	123	123	123
Connection type	Conexión por tornillo / Screw terminals		
Wire flexible (mm²)	16 - 50		
Weight (g)	804	896	995

- Terminales con tornillo allen
- Material: PA6
- Contactos: Latón
- Para pedir con contacto piloto añadir una *P, ej. 24337P
- IP67 Hermético
- With screw terminals allen
- Housing material: PA6
- Contacts: Brass
- To order with Pilot contact add please a *P, eg. 24337P
- IP67 Watertight

125	3	2	443-4	443-6	24342	24443
	4	2	24140	24239	24337	24436
	5	2	24142	24277	24338	24440



Ref. / Item 24337



BASES DE PARED IP44 / IP44 WALL MOUNTED SOCKETS

SpeedPRO IP44
base de pared ECO / wall mounted socket ECO

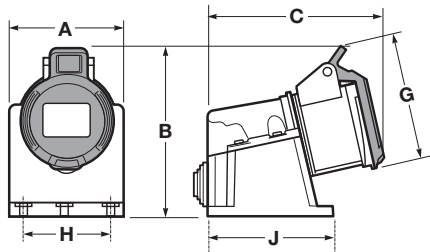

Poles	16A			32A		
	3	4	5	3	4	5
A	75	75	79	79	79	79
B	112	117	120	128	128	131
C	110	110	117	127	127	130
G	85	94	102	102	102	110
H	58	58	62	62	62	62
J	80	80	85	85	85	85
Connection type	Conexión por tornillo / Screw terminals					
Wire flexible (mm²)	1 - 2,5			2,5 - 6		
Weight (g)	220	228	250	271	290	314

- Terminales con tornillo
 - Material: PA6/ABS
 - Contactos: Niquelados
 - Entrada trasera
- IP44 a prueba de salpicaduras**
- With screw terminals
 - Housing material: PA6/ABS
 - Contacts: Nickel-plated contacts
 - Rear entry
- IP44 Splashproof**

SpeedPRO IP44
base de pared / wall mounted socket

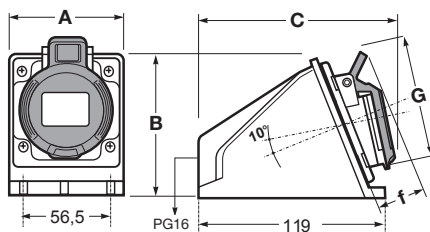

Montaje bases de 16A / 16A socket mounting

Poles	16A			32A		
	3	4	5	3	4	5
A	81	81	81	81	81	81
B	97	97	97	97	97	97
C	158	198	199	176	176	178
G	85	94	102	102	102	110
f	48	48	48	57	57	57
Connection type	Conexión por tornillo / Screw terminals					
Wire flexible (mm²)	1 - 2,5			2,5 - 6		
Weight (g)	285	297	315	322	330	362

- Terminales con tornillo
 - Material: PA6/ABS
 - Contactos: Niquelados
 - Entrada trasera
- IP44 a prueba de salpicaduras**
- With screw terminals
 - Housing material: PA6/ABS
 - Contacts: Nickel-plated contacts
 - Rear entry
- IP44 Splashproof**

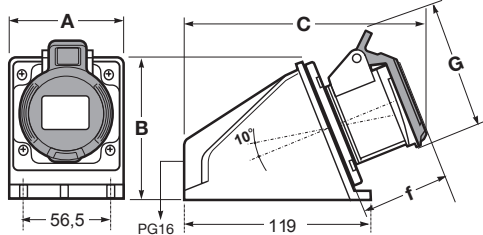

Montaje bases de 32A / 32A socket mounting

3P = 2P + T
4P = 3P + T
5P = 3P + T + N

110V
50/60Hz

230V
50/60Hz

400V
50/60Hz

500V
50/60Hz

Amp	Poles	Pack unit	Poles: 3P 4P 5P Hour P: 4h 4h 4h	Poles: 3P 4P 5P Hour P: 6h 9h 9h	Poles: 3P 4P 5P Hour P: 9h 6h 6h	Poles: 3P 4P 5P Hour P: 7h 7h 7h
-----	-------	-----------	-------------------------------------	-------------------------------------	-------------------------------------	-------------------------------------

16	3	10	2531	2532	23398	23481
	4	10	23197	23298	2535	23482
	5	6	23198	23299	2545	23483
32	3	6	23199	2541	23407	23484
	4	6	23206	23307	2546	23485
	5	6	23207	23308	2547	23486



Ref. / Item 23397



16	3	3	23190	23290	23406	23494
	4	3	23191	23291	23390	23490
	5	3	23194	23295	23391	23491
32	3	2	23192	23292	23394	23495
	4	2	23193	23293	23392	23492
	5	2	23195	23296	23393	23493



Ref. / Item 23290



1.1 CONEXIÓN POR TORNILLOS SpeedPro
SCREW CONNECTION SpeedPro

BASES DE PARED IP67 / IP67 WALL MOUNTED SOCKETS

SpeedPRO IP67
base de pared / wall mounted socket

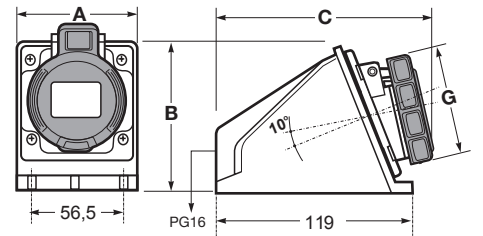

Montaje bases de 16A / 16A socket mounting

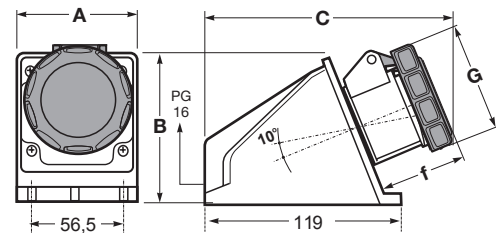

Montaje bases de 32A / 32A socket mounting

Poles	16A			32A		
	3	4	5	3	4	5
A	81	81	81	81	81	81
B	97	97	97	97	97	97
C	158	198	199	176	176	176
G	70	78	85	92	92	99,5
f	48	48	48	57	57	57
Connection type	Conexión por tornillo / Screw terminals					
Wire flexible (mm²)	1 - 2,5			2,5 - 6		
Weight (g)	290	302	320	327	335	367

- Terminales con tornillo
- Material: PA6/ABS
- Contactos: Niquelados
- Entrada trasera

IP67 Hermético

- With screw terminals
- Housing material: PA6/ABS
- Contacts: Nickel-plated contacts
- Rear entry

IP67 Watertight

3P = 2P + T
4P = 3P + T
5P = 3P + T + N

110V	230V	400V	500V
50/60Hz	50/60Hz	50/60Hz	50/60Hz

Amp	Poles	Pack unit	Poles: 3P 4P 5P Hour P: 4h 4h 4h	Poles: 3P 4P 5P Hour P: 6h 9h 9h	Poles: 3P 4P 5P Hour P: 9h 6h 6h	Poles: 3P 4P 5P Hour P: 7h 7h 7h
-----	-------	-----------	-------------------------------------	-------------------------------------	-------------------------------------	-------------------------------------

16	3	3	24190	24290	24399	24494
	4	3	24191	24291	24390	24490
	5	3	24198	24295	24391	24491

32	3	2	24192	24292	24408	24488
	4	2	24193	24293	24392	24492
	5	2	24199	24296	24393	24493



Ref. / Item 24391



SpeedPRO IP67
base de pared / wall mounted socket

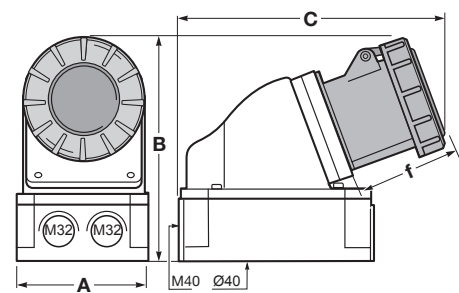

Poles	63A		
	3	4	5
A	118	118	118
B	190	190	190
C	220	220	220
f	82	82	82
Connection type	Conexión por tornillo / Screw terminals		
Wire flexible (mm²)	6 - 16		
Weight (g)	840	850	860

- Terminales con tornillo allen
- Material: PA6/ABS
- Contactos: Latón
- Entradas superiores, inferiores y traseras.
- Para pedir con contacto piloto añadir una *P, ej. 24194P
- El conjunto de la toma puede montarse simétricamente a 180° sobre su base

IP67 Hermético

- With screw terminals allen
- Housing material: PA6/ABS
- Contacts: Brass with pilot contact
- Top, 2 x Bottom and rear entry
- To order with Pilot contact add please a *P, eg. 24194P
- Housing can be rotated by 180°

IP67 Watertight

63	3	3	1259	1263	24409	24486
	4	3	1260	1264	24394	24496
	5	3	24512	24257	24395	24497



Ref. / Item 24395



SpeedPRO IP67
base de pared / wall mounted socket

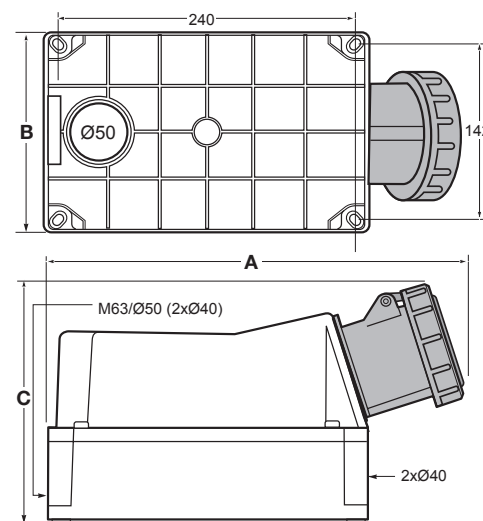

Poles	125A		
	3	4	5
A	322	322	322
B	162	162	162
C	220	220	220
D	60	60	60
Connection type	Conexión por tornillo / Screw terminals		
Wire flexible (mm²)	16 - 50		
Weight (g)	1745	1752	1852

- Terminales con tornillos allen
- Material: PA6/ABS
- Contactos: Latón
- Entradas superiores, inferiores y traseras
- El conjunto de la toma puede montarse simétricamente a 180° sobre su base
- Para pedir con contacto piloto añadir una *P, ej. 24196P

IP67 Hermético

- With Screw terminals allen
- Housing material: PA6/ABS
- Contacts: Brass
- Top, Bottom and rear entry
- To order with Pilot contact add please a *P, eg. 24196P
- Housing can be rotated by 180°

IP67 Watertight

125	3	1	143-4	143-6	24489	24487
	4	1	24197	24258	24396	24498
	5	1	24213	24297	24397	24499



Ref. / Item 24396



BASES DE PARED / WALL MOUNTED SOCKETS

SpeedPRO IP44
base de pared / wall mounted socket

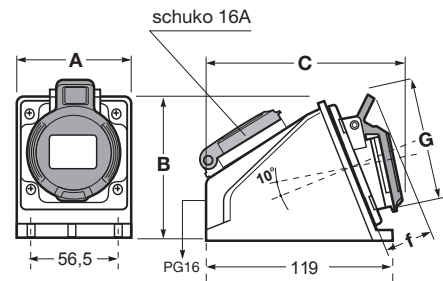

Montaje bases de 16A / 16A socket mounting

Poles	16A		
	3	4	5
A	81	81	81
B	97	97	97
C	158	198	199
G	85	94	102
f	48	48	48
Connection type	Conexión por tornillo / Screw terminals		
Wire flexible (mm ²)	1 - 2,5		
Weight (g)	285	297	315

- Terminales con tornillo
- Material: PA6/ABS
- Contactos: Niquelados
- Entrada trasera
- No cableada

IP44 A prueba de salpicaduras

- With screw terminals
- Housing material: PA6/ABS
- Contacts: Nickel-plated contacts
- Rear entry
- Unwired

IP44 Splashproof

3P = 2P + T
4P = 3P + T
5P = 3P + T + N

230V
50/60Hz

400V
50/60Hz

Amp	Poles	Pack unit	230V 50/60Hz	400V 50/60Hz
			Poles: 3P 4P 5P Hour P: 6h 9h 9h	Poles: 3P 4P 5P Hour P: 9h 6h 6h

16	3	3	23609	--
	4	3	23602	23605
	5	3	--	23606

Disponible también con toma británica y francesa, consultar.
Available also with Britain and French socket, please consult.



Ref. / Item 23606



CAJAS VACÍAS DE SUPERFICIE PARA BASES DE CUADRO / SURFACE EMPTY BOXES FOR PANEL SOCKETS

Caja 16/32A / Box 16/32A

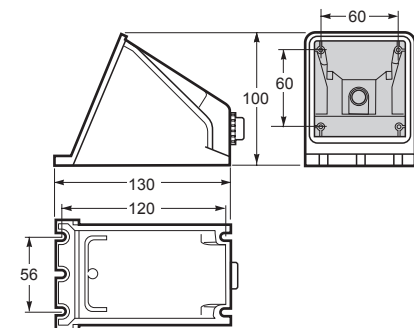

- Para 16A IP44/67, montar base de cuadro inclinada 75x85, ver páginas 36-37
- Para 32A IP44/67, montar base de cuadro salida recta 75x85, ver páginas 34-35
- For 16A IP44/67, it must be mounted with angled panel socket 75x85, see at pages 36-37
- For 32A IP44/67, it must be mounted with straight panel socket 75x85, see at pages 34-35

Amp	Pack unit	
16/32	4	23000

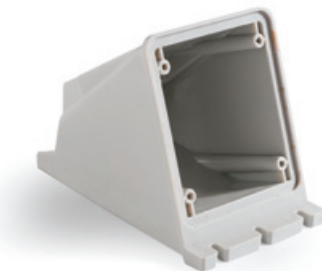

Ref. / Item 23000



Caja 16A / Box 16A

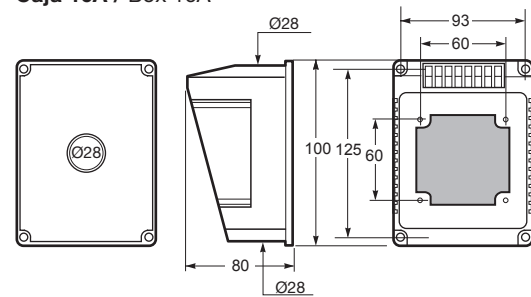

- Para 16A IP44/67, montar base de cuadro inclinada 75x85, ver página 36-37
- For 16A IP44/67, it must be mounted with angled panel socket 75x85, see at page 36-37

Amp	Pack unit	
16	3	23001
32	3	23002



Ref. / Item 23001 / 23002



Caja 32A / Box 32A

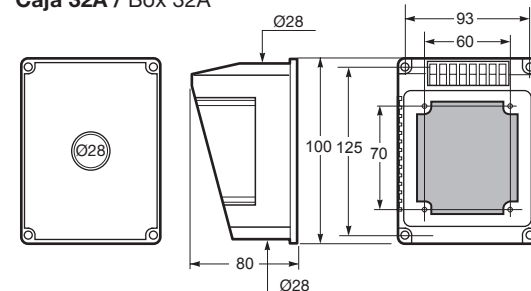

- Para 32A IP44/67, montar base de cuadro inclinada 80x95, ver página 36-37
- For 32A IP44/67, it must be mounted with angled panel socket 80x95, see at page 36-37

1.2 CONEXIÓN RÁPIDA SIN TORNILLOS TOP SpeedPro

SCREWLESS QUICK CONNECTION TOP SpeedPro

1 Insertar cable en toma.

Insert the cable into the socket.

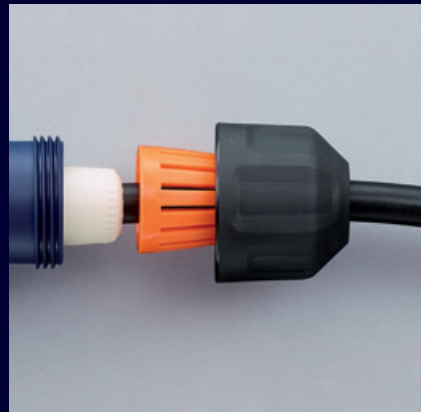

2 Conectar TOP SpeedPRO. Insertar el cable en los terminales y cerrar las pestañas. Reducción en un 50% de tiempos de instalación. Conexión garantizada en todo tipo de instalación.

Connect TOP SpeedPRO. Insert the cable into the terminals and close the tabs. A 50% reduction in installation time. Guaranteed connection in all types of installations.



3 Ubicar y girar la guía hasta oír el click.

Locate and turn the guide until you hear click.



4 Apretar prensacable para evitar que el esfuerzo de tracción y torsión se transmita al final del conductor.

Tighten the cable gland to prevent the tensile and torsional stresses from being transmitted at the end of the conductor.



COLECCIÓN COLLECTION

TOP SpeedPRO

CLAVIJAS AÉREAS

MOBILE PLUGS

Pg. 47



BASES AÉREAS

MOBILE SOCKETS

Pg. 47



1.2 CONEXIÓN RÁPIDA SIN TORNILLOS TOP SpeedPRO
SCREWLESS QUICK CONNECTION TOP SpeedPRO

CLAVIJAS Y BASES AEREAS / MOBILE PLUGS AND SOCKETS

TOP SpeedPRO IP44
clavija aerea / mobile plug

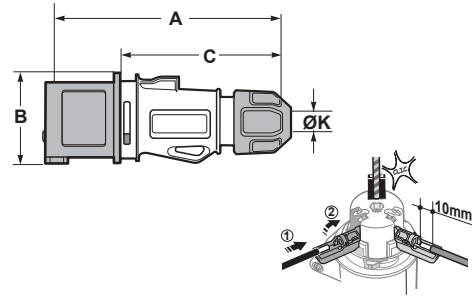

Poles	16A		
	3	4	5
A	150	150	150
B	56	60	73
C	110	110	110
ØK	6-15	6-15	8-16
Connection type	Conexión sin tornillos / Screwless connection		
Wire flexible (mm ²)	1 - 2,5		
Weight (g)	123	139	157

- Tecnología de conexión sin tornillos
- Material: PA6/ABS
- Contactos: Latón
- IP44 a prueba de salpicaduras
- Screwless connection technology
- Housing material: PA6/ABS
- Contacts: Brass
- IP44 Splashproof

TOP SpeedPRO IP67
clavija aerea / mobile plug

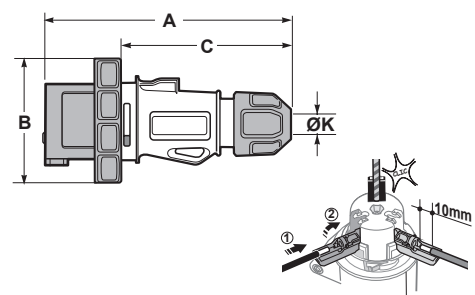

Poles	16A		
	3	4	5
A	157	157	157
B	70	70	70
C	110	110	110
ØK	6-15	6-15	8-16
Connection type	Conexión sin tornillos / Screwless connection		
Wire flexible (mm ²)	1 - 2,5		
Weight (g)	142	158	173

- Tecnología de conexión sin tornillos
- Material: PA6/ABS
- Contactos: Latón
- IP67 Hermético
- Screwless connection technology
- Housing material: PA6/ABS
- Contacts: Brass
- IP67 Watertight

TOP SpeedPRO IP44
base aerea / mobile socket

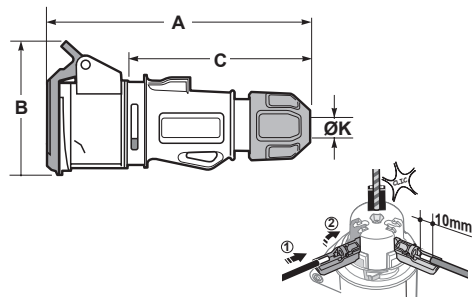

Poles	16A		
	3	4	5
A	157	157	157
B	85	91	97
C	110	110	110
ØK	6-15	6-15	8-16
Connection type	Conexión sin tornillos / Screwless connection		
Wire flexible (mm ²)	1 - 2,5		
Weight (g)	215	230	252

- Tecnología de conexión sin tornillos
- Material: PA6/ABS
- Contactos: Niquelado
- IP44 a prueba de salpicaduras
- Screwless connection technology
- Housing material: PA6/ABS
- Contacts: Nickel-plated contacts
- IP44 Splashproof

TOP SpeedPRO IP67
base aerea / mobile socket

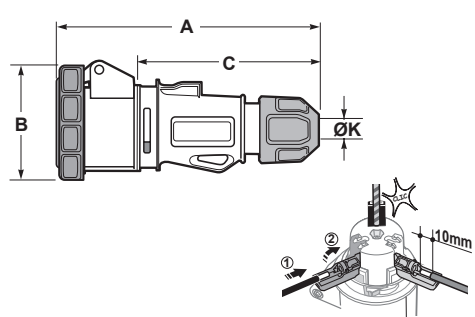

Poles	16A		
	3	4	5
A	157	157	157
B	70	70	70
C	110	110	110
ØK	6-15	6-15	8-16
Connection type	Conexión sin tornillos / Screwless connection		
Wire flexible (mm ²)	1 - 2,5		
Weight (g)	142	158	173

- Tecnología de conexión sin tornillos
- Material: PA6/ABS
- Contactos: Niquelado
- IP67 Hermético
- Screwless connection technology
- Housing material: PA6/ABS
- Contacts: Nickel-plated contacts
- IP67 Watertight

3P = 2P + T
4P = 3P + T
5P = 3P + T + N

230V
50/60Hz

400V
50/60Hz

Amp	Poles	Pack unit	230V 50/60Hz	400V 50/60Hz
16	3	10	13200CR	--
	4	10	--	13300CR
	5	6	--	13301CR

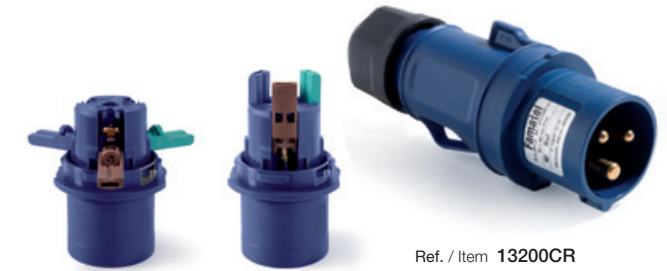

Ref. / Item 13200CR



16	3	10	13200CR	--
	4	10	--	13300CR
	5	6	--	13301CR

16	3	10	14200CR	--
	4	8	--	14300CR
	5	8	--	14301CR



Ref. / Item 14200CR



16	3	10	23200CR	--
	4	10	--	23300CR
	5	5	--	23301CR



Ref. / Item 23200CR



16	3	10	24200CR	--
	4	6	--	24300CR
	5	4	--	24301CR



Ref. / Item 24200CR



2 BASES INTERBLOCANTES INDUSTRIALES IP44/67
INDUSTRIAL SWITCHED INTERLOCKED SOCKETS IP44/67

Las bases interblocantes SpeedPRO, disponibles también en IP44 y IP67, están diseñadas para su uso en aquellos lugares industriales donde la seguridad es si cabe, más importante todavía. Gracias a su bloqueo en el interruptor, esta gama ofrece una perfecta solución y garantiza una intalación segura y de calidad.

The SpeedPRO switched interlocked sockets, which are also available in IP44 and IP67, are designed for use in industrial locations where security is even more important. Thanks to its locking system on the switch, this range offers a perfect solution and guarantees a safe and quality installation.



- Alta resistencia corrosión
- Alto grado de resistencia al impacto
- Protección contra los agentes químicos
- Interruptor de seguridad ON/OFF

- High corrosion resistance
- High impact resistance
- Protection against chemical agents
- Safety switch ON/OFF



Proyecto planta de gas Pemex Mexico
Gas Pemex Mexico plan Project



Proyecto mina Chinalco Perú
Chinalco Peru mine



BLOQUEO CONEXIONADO MECÁNICO
MECHANICAL INTERLOCKED



Después de puesto el switch en OFF y extraída la clavija, el mando queda bloqueado.
After switching-off and unplugging switch locked.



Después del conexionado y puesto en posición ON, la clavija queda bloqueada.
After plugging and switching-on the plug is locked.

BASES INTERBLOCANTES CUADRO VERTICAL

SWITCHED INTERLOCKED PANEL SOCKET VERTICAL

Pg. 53



BASES INTERBLOCANTES SUPERFICIE VERTICAL

SWITCHED INTERLOCKED WALL MOUNTED SOCKET VERTICAL

Pg. 55



BASES INTERBLOCANTES CUADRO HORIZONTAL

SWITCHED INTERLOCKED WALL PANEL SOCKET HORIZONTAL

Pg. 57



BASES INTERBLOCANTES SUPERFICIE HORIZONTAL

SWITCHED INTERLOCKED WALL MOUNTED SOCKET HORIZONTAL

Pg. 59



BASES INTERLOCANTES CUADRO CON CARRIL DIN

SWITCHED INTERLOCKED PANEL SOCKET WITH DIN RAIL

Pg. 61



BASES INTERLOCANTES SUPERFICIE CON CARRIL DIN

SWITCHED INTERLOCKED WALL MOUNTED SOCKET WITH DIN RAIL

Pg. 63



BASES INTERLOCANTES DE CUADRO CON MAGNETOTÉRMICO 63A

SWITCHED INTERLOCKED PANEL SOCKET WITH MCB 63A

Pg. 69



BASES INTERLOCANTES DE SUPERFICIE 63A

SWITCHED INTERLOCKED WALL MOUNTED SOCKET 63A

Pg. 67



BASES INTERBLOCANTES SUPERFICIE 125 A

SWITCHED INTERLOCKED WALL MOUNTED SOCKET 125 A

Pg. 71



BASES INTERBLOCANTES CUADRO VERTICAL / SWITCHED INTERLOCKED PANEL SOCKET VERTICAL

SpeedPRO IP44

base interblocante cuadro vertical / switched interlocked panel socket vertical

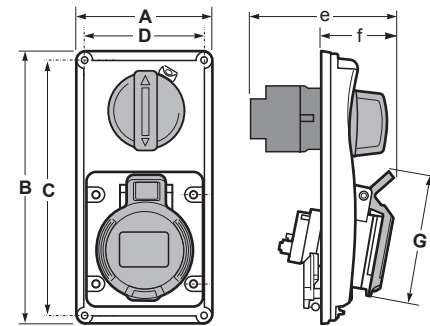

Poles	16A			32A		
	3	4	5	3	4	5
A	90	90	90	80	90	80
B	180	180	180	95	180	95
C	169	169	169	60	169	60
D	79	79	79	70	79	70
e	100	103	107	111	111	111
f	50	53	56	60	60	60
G	86	94	102	108	108	108
Connection type	Conexión por tornillo / Screw terminals					
Wire flexible (mm²)	1 - 2,5			2,5 - 6		
Weight (g)	361	372	397	425	435	455

- Terminales con tornillo
 - Material: PA6/ABS
 - Contactos: Niquelados
 - Bloqueo conexionado mecánico
- IP44 a prueba de salpicaduras**
- With screw terminals
 - Housing material: PA6/ABS
 - Contacts: Nickel-plated contacts
 - Mechanical Interlocked
- IP44 Splashproof**

3P = 2P + T
4P = 3P + T
5P = 3P + T + N

110V	230V	400V
50/60Hz	50/60Hz	50/60Hz

Amp	Poles	Pack unit	110V	230V	400V
			Poles: 3P 4P 5P Hour P: 4h 4h 4h	Poles: 3P 4P 5P Hour P: 6h 9h 9h	Poles: 3P 4P 5P Hour P: 9h 6h 6h

16	3	1	25031	25033	25023
	4	1	25032	25034	25036
	5	1	25019	25035	25037
32	3	1	25038	25040	25024
	4	1	25039	25041	25043
	5	1	25020	25042	25044



Ref. / Item 25033



SpeedPRO IP67

base interblocante cuadro vertical / switched interlocked panel socket vertical

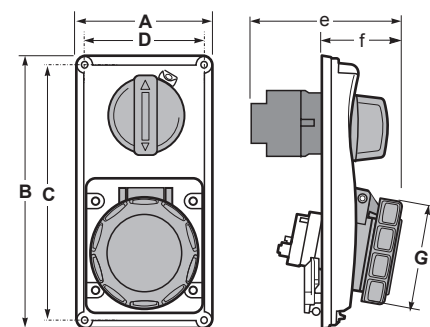

Poles	16A			32A		
	3	4	5	3	4	5
A	90	90	90	80	90	80
B	180	180	180	95	180	95
C	169	169	169	60	169	60
D	79	79	79	70	79	70
e	107	107	100	112	114	114
f	52	56	50	62	63	64
G	70	78	85	108	108	108
Connection type	Conexión por tornillo / Screw terminals					
Wire flexible (mm²)	1 - 2,5			2,5 - 6		
Weight (g)	375	385	405	440	455	485

- Terminales con tornillo
 - Material: PA6/ABS
 - Contactos: Niquelados
 - Bloqueo conexionado mecánico
- IP67 Hermético**
- With screw terminals
 - Housing material: PA6/ABS
 - Contacts: Nickel-plated contacts
 - Mechanical Interlocked
- IP67 Watertight**

16	3	1	25045	25000	25075
	4	1	25046	25047	25001
	5	1	25021	25048	25002
32	3	1	25049	25003	25076
	4	1	25050	25051	25004
	5	1	25022	25052	25005



Ref. / Item 25002



- Bloqueo conexionado mecánico:
 - Después del conexionado de la clavija y puesto el swich en ON, la clavija queda bloqueada
 - Después de puesto el swich en OFF y extraída la clavija, el mando queda bloqueado.
- Mechanical interlocked:
 - After plugging and switching-on the plug is locked.
 - After switching-off and unplugging switch is locked.

En posición ON o OFF del mando es posible de poner candado por seguridad
At switch ON or OFF position, its possible to be lockable by padlock



BASES INTERBLOCANTES SUPERFICIE VERTICAL / SWITCHED INTERLOCKED WALL MOUNTED SOCKET VERTICAL

SpeedPRO IP44

base interbloqueante superficie vertical / switched interlocked wall mounted socket vertical

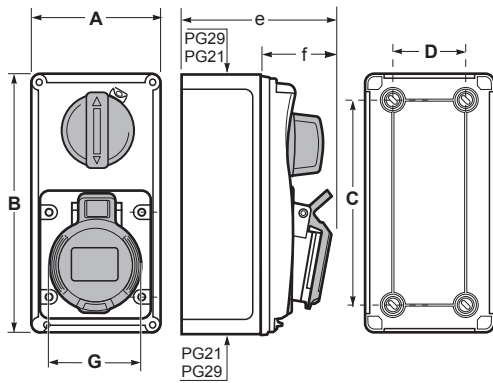

Poles	16A			32A		
	3	4	5	3	4	5
A	90	90	90	90	90	90
B	180	180	180	95	180	180
C	140	140	140	140	140	140
D	79	79	79	70	79	70
e	105	108	111	165	165	165
f	50	53	56	60	60	60
G	62	62	62	76	82	87
Connection type	Conexión por tornillo / Screw terminals					
Wire flexible (mm²)	1 - 2,5			2,5 - 6		
Weight (g)	488	499	524	552	562	582

- Terminales con tornillo
 - Material: PA6/ABS
 - Contactos: Niquelados
 - Bloqueo conexionado mecánico
- IP44 a prueba de salpicaduras**
- With screw terminals
 - Housing material: PA6/ABS
 - Contacts: Nickel-plated contacts
 - Mechanical Interlocked
- IP44 Splashproof**

3P = 2P + T
4P = 3P + T
5P = 3P + T + N

110V	230V	400V
50/60Hz	50/60Hz	50/60Hz

Amp	Poles	Pack unit	110V	230V	400V
			Poles: 3P 4P 5P Hour P: 4h 4h 4h	Poles: 3P 4P 5P Hour P: 6h 9h 9h	Poles: 3P 4P 5P Hour P: 9h 6h 6h

Amp	Poles	Pack unit	110V	230V	400V
16	3	1	19.3214G4	19.3214B6	26033
	4	1	19.3314G4	19.3314B9	19.3314R6
	5	1	19.3414G4	19.3414B9	19.3414R6
32	3	1	19.3234G4	19.3234B6	26034
	4	1	19.3334G4	19.3334B9	19.3334R6
	5	1	19.3434G4	19.3434B9	19.3434R6



Ref. / Item 26008



SpeedPRO IP67

base interbloqueante superficie vertical / switched interlocked wall mounted socket vertical

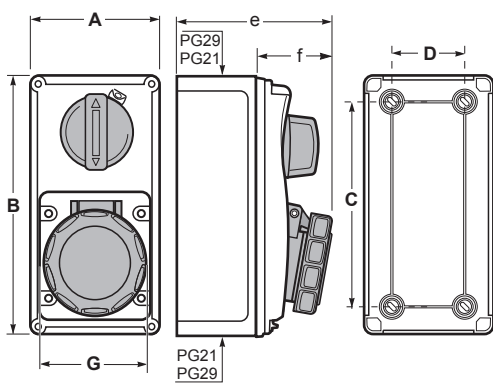

Poles	16A			32A		
	3	4	5	3	4	5
A	90	90	90	90	90	90
B	180	180	180	95	180	180
C	140	140	140	140	140	140
D	79	79	79	70	79	70
e	105	108	111	165	165	165
f	50	53	56	60	60	60
G	62	62	62	76	82	87
Connection type	Conexión por tornillo / Screw terminals					
Wire flexible (mm²)	1 - 2,5			2,5 - 6		
Weight (g)	488	499	524	552	562	582

- Terminales con tornillo
 - Material: PA6/ABS
 - Contactos: Niquelados
 - Bloqueo conexionado mecánico
- IP67 Hermético**
- With screw terminals
 - Housing material: PA6/ABS
 - Contacts: Nickel-plated contacts
 - Mechanical Interlocked
- IP67 Watertight**

Amp	Poles	Pack unit	110V	230V	400V
16	3	1	19.3216G4	19.3216B6	26035
	4	1	19.3316G4	19.3316B9	19.3316R6
	5	1	19.3416G4	19.3416B9	19.3416R6
32	3	1	19.3232G4	19.3232B6	26036
	4	1	19.3332G4	19.3332B9	19.3332R6
	5	1	19.3432G4	19.3432B9	19.3434R6



Ref. / Item 26002



- Bloqueo conexionado mecánico:
 - Después del conexionado de la clavija y puesto el swich en ON, la clavija queda bloqueada
 - Después de puesto el swich en OFF y extraída la clavija, el mando queda bloqueado.
- Mechanical interlocked:
 - After plugging and switching-on the plug is locked.
 - After switching-off and unplugging switch is locked.

En posición ON o OFF del mando es posible de poner candado por seguridad
At switch ON or OFF position, its possible to be lockable by padlock



BASES INTERBLOCANTES CUADRO HORIZONTAL / SWITCHED INTERLOCKED PANEL SOCKET HORIZONTAL

SpeedPRO IP44

base interblocante cuadro horizontal / switched interlocked panel socket horizontal

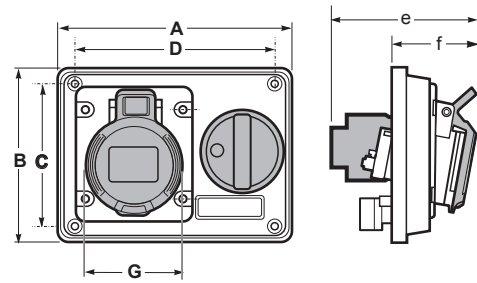

Poles	16A			32A		
	3	4	5	3	4	5
A	155	155	155	155	155	155
B	115	115	115	115	115	115
C	98	98	98	98	98	98
D	138	138	138	138	138	138
e	90	93	97	101	101	101
f	50	53	56	76	82	87
G	62	62	62	76	82	87
Connection type	Conexión por tornillo / Screw terminals					
Wire flexible (mm ²)	1 - 2,5			2,5 - 6		
Weight (g)	406	416	441	469	479	499

- Terminales con tornillo
 - Material: PA6/ABS
 - Contactos: Niquelados
 - Bloqueo conexionado mecánico
- IP44** a prueba de salpicaduras
- With screw terminals
 - Housing material: PA6/ABS
 - Contacts: Nickel-plated contacts
 - Mechanical Interlocked
- IP44** Splashproof

3P = 2P + T
4P = 3P + T
5P = 3P + T + N

110V	230V	400V
50/60Hz	50/60Hz	50/60Hz

Amp	Poles	Pack unit	110V	230V	400V
			Poles: 3P 4P 5P Hour P: 4h 4h 4h	Poles: 3P 4P 5P Hour P: 6h 9h 9h	Poles: 3P 4P 5P Hour P: 9h 6h 6h

Amp	Poles	Pack unit	110V	230V	400V
16	3	1	25054	25056	25079
	4	1	25055	25057	25059
	5	1	25085	25058	25060
32	3	1	25137	25063	25080
	4	1	25061	25064	25066
	5	1	25086	25065	25067



Ref. / Item 25056



SpeedPRO IP67

base interblocante cuadro horizontal / switched interlocked panel socket horizontal

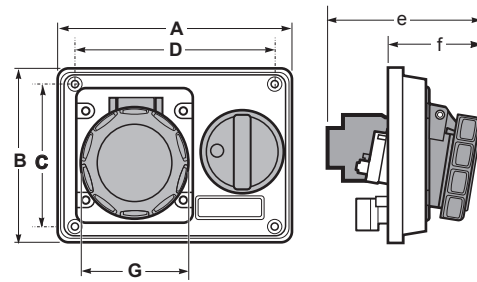

Poles	16A			32A		
	3	4	5	3	4	5
A	155	155	155	155	155	155
B	115	115	115	115	115	115
C	98	98	98	98	98	98
D	138	138	138	138	138	138
e	97	97	100	102	104	104
f	52	56	50	62	63	64
G	70	78	85	108	108	108
Connection type	Conexión por tornillo / Screw terminals					
Wire flexible (mm ²)	1 - 2,5			2,5 - 6		
Weight (g)	419	429	449	484	499	529

- Terminales con tornillo
 - Material: PA6/ABS
 - Contactos: Niquelados
 - Bloqueo conexionado mecánico
- IP67** Hermético
- With screw terminals
 - Housing material: PA6/ABS
 - Contacts: Nickel-plated contacts
 - Mechanical Interlocked
- IP67** Watertight

Amp	Poles	Pack unit	110V	230V	400V
16	3	1	25138	25008	25081
	4	1	25139	25068	25009
	5	1	25077	25069	25010
32	3	1	25070	25011	25082
	4	1	25071	25072	25012
	5	1	25078	25073	25013



Ref. / Item 25010



- Bloqueo conexionado mecánico:
 - Después del conexionado de la clavija y puesto el swich en ON, la clavija queda bloqueada
 - Después de puesto el swich en OFF y extraída la clavija, el mando queda bloqueado.
- Mechanical interlocked:
 - After plugging and switching-on the plug is locked.
 - After switching-off and unplugging switch is locked.

En posición ON o OFF del mando es posible de poner candado por seguridad
At switch ON or OFF position, its possible to be lockable by padlock



BASES INTERBLOCANTES SUPERFICIE HORIZONTAL / SWITCHED INTERLOCKED WALL MOUNTED SOCKET HORIZONTAL

SpeedPRO IP44

base interbloqueante superficie horizontal / switched interlocked wall mounted socket horizontal

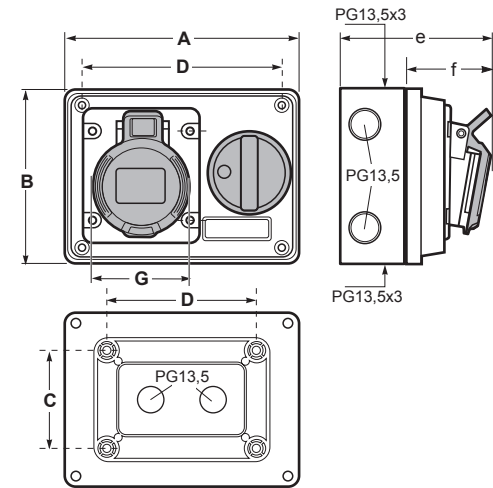

Poles	16A			32A		
	3	4	5	3	4	5
A	155	155	155	155	155	155
B	115	115	115	115	115	115
C	72	72	72	72	72	72
D	113	113	113	113	113	113
e	105	108	111	115	115	115
f	50	53	56	60	60	60
G	62	62	62	76	82	86
Connection type	Conexión por tornillo / Screw terminals					
Wire flexible (mm²)	1 - 2,5			2,5 - 6		
Weight (g)	521	531	541	584	594	614

- Terminales con tornillo
 - Material: PA6/ABS
 - Contactos: Niquelados
 - Bloqueo conexionado mecánico
- IP44 a prueba de salpicaduras**
- With screw terminals
 - Housing material: PA6/ABS
 - Contacts: Nickel-plated contacts
 - Mechanical Interlocked
- IP44 Splashproof**

3P = 2P + T
4P = 3P + T
5P = 3P + T + N

110V	230V	400V
50/60Hz	50/60Hz	50/60Hz

Amp	Poles	Pack unit	110V	230V	400V
			Poles: 3P 4P 5P Hour P: 4h 4h 4h	Poles: 3P 4P 5P Hour P: 6h 9h 9h	Poles: 3P 4P 5P Hour P: 9h 6h 6h

16	3	1	3214G4	3214B6	25148
	4	1	3314G4	3314B9	3314R6
	5	1	3414G4	3414B9	3434R6
32	3	1	3234G4	3234B6	25149
	4	1	3334G4	3334B9	3334R6
	5	1	25145	3434B9	3414R6



Ref. / Item 25116



SpeedPRO IP67

base interbloqueante superficie horizontal / switched interlocked wall mounted socket horizontal

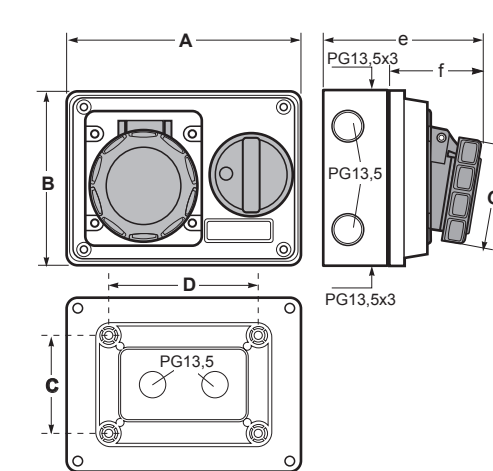

Poles	16A			32A		
	3	4	5	3	4	5
A	155	155	155	155	155	155
B	115	115	115	115	115	115
C	72	72	72	72	98	98
D	113	113	113	113	113	113
e	107	111	114	117	118	119
f	52	56	59	62	63	64
G	86	94	102	108	108	108
Connection type	Conexión por tornillo / Screw terminals					
Wire flexible (mm²)	1 - 2,5			2,5 - 6		
Weight (g)	534	544	584	599	614	644

- Terminales con tornillo
 - Material: PA6/ABS
 - Contactos: Niquelados
 - Bloqueo conexionado mecánico
- IP67 Hermético**
- With screw terminals
 - Housing material: PA6/ABS
 - Contacts: Nickel-plated contacts
 - Mechanical Interlocked
- IP67 Watertight**

16	3	1	3216G4	3216B6	25150
	4	1	3316G4	3316B9	3316R6
	5	1	25146	3416B9	3416R6
32	3	1	3232G4	3232B6	25151
	4	1	3416G4	3332B9	3332R6
	5	1	3432G4	3432B9	3432R6



Ref. / Item 25110



- Bloqueo conexionado mecánico:
 - Después del conexionado de la clavija y puesto el swich en ON, la clavija queda bloqueada
 - Después de puesto el swich en OFF y extraida la clavija, el mando queda bloqueado.
- Mechanical interlocked:
 - After plugging and switching-on the plug is locked.
 - After switching-off and unplugging switch is locked.

En posición ON o OFF del mando es posible de poner candado por seguridad
At switch ON or OFF position, its possible to be lockable by padlock



BASES INTERBLOCANTES CUADRO CON CARRIL DIN / SWITCHED INTERLOCKED PANEL SOCKET WITH DIN RAIL

SpeedPRO IP44

base interbloqueante cuadro con carril DIN / switched interlocked panel socket with DIN rail

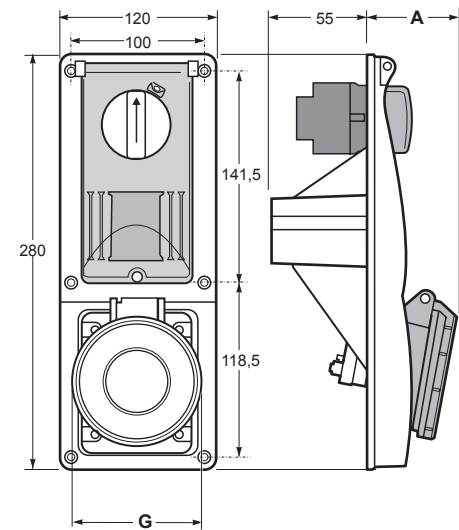

Poles	16A			32A		
	3	4	5	3	4	5
A	64	65,5	67	72,5	72,5	73,5
G	60	68	76	81	81	89
Connection type	Conexión por tornillo / Screw terminals					
Wire flexible (mm²)	1 - 2,5			2,5 - 6		
Weight (g)	686	692	702	796	802	812

- Si se quiere pedir con portafusible 10.3x38 50/60Hz, añadimos *FH, ej. 25706FH
- If you want to order with Fuse Holder 10.3x38 50/60Hz, add *FH, eg. 25706FH
- Si se quiere pedir con Magnetotérmico curva C reactivable desde el exterior + Luz de aviso de línea, añadimos *MCB, ej. 25706MCB
- If you want to order with MCB-Type C reactivable from the outside + Led warning light to signal the line connection, add *MCB, eg. 25706MCB

- Terminales con tornillo
- Material: PA6/ABS
- Contactos: Niquelados
- Bloqueo conexión mecánico
- Con carril DIN de 4 módulos y ventana abatible

IP44 a prueba de salpicaduras

- With screw terminals
- Housing material: PA6/ABS
- Contacts: Nickel-plated contacts
- Mechanical Interlocked
- With DIN-rail and hinged window for 4 modules

IP44 Splashproof

3P = 2P + T
4P = 3P + T
5P = 3P + T + N

110V	230V	400V
50/60Hz	50/60Hz	50/60Hz

Amp	Poles	Pack unit	110V	230V	400V
			Poles: 3P 4P 5P Hour P: 4h 4h 4h	Poles: 3P 4P 5P Hour P: 6h 9h 9h	Poles: 3P 4P 5P Hour P: 9h 6h 6h

16	3	1	16.3214G4R	16.3214B6R	25734
	4	1	16.3314G4R	16.3314B9R	16.3314R6R
	5	1	16.3414G4R	16.3414B9R	16.3414R6R
32	3	1	16.3234G4R	16.3234B6R	25735
	4	1	16.3334G4R	16.3334B9R	16.3334R6R
	5	1	16.3434G4R	16.3434B9R	16.3434R6R



Ref. / Item 25703



SpeedPRO IP67

base interbloqueante cuadro con carril DIN / switched interlocked panel socket with DIN rail

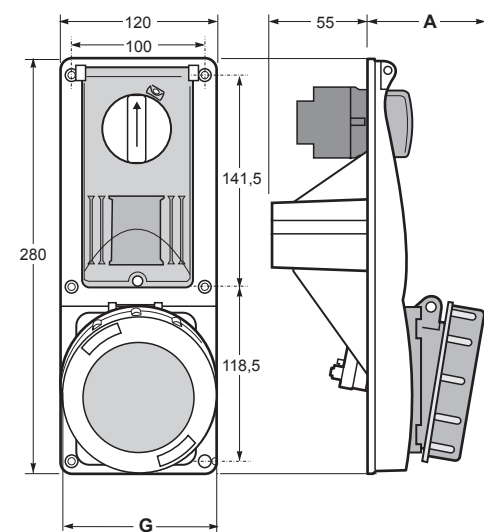

Poles	16A			32A		
	3	4	5	3	4	5
A	66	66,5	69	73,5	73,5	73,5
G	71	77	87	92	96	98
Connection type	Conexión por tornillo / Screw terminals					
Wire flexible (mm²)	1 - 2,5			2,5 - 6		
Weight (g)	696	706	715	810	822	832

- Si se quiere pedir con portafusible 10.3x38 50/60Hz, añadimos *FH, ej. 25720FH
- If you want to order with Fuse Holder 10.3x38 50/60Hz, add *FH, eg. 25720FH
- Si se quiere pedir con Magnetotérmico curva C reactivable desde el exterior + Luz de aviso de línea, añadimos *MCB, ej. 25720MCB
- If you want to order with MCB-Type C reactivable from the outside + Led warning light to signal the line connection, add *MCB, eg. 25720MCB

- Terminales con tornillo
- Material PA6/ABS
- Contactos: Niquelados
- Bloqueo conexión mecánico
- Con carril DIN de 4 módulos y ventana abatible

IP67 Hermético

- With screw terminals
- Housing material: PA6/ABS
- Contacts: Nickel-plated contacts
- Mechanical Interlocked
- With DIN-rail and hinged window for 4 modules

IP67 Watertight

16	3	1	16.3216G4R	16.3216B6R	25736
	4	1	16.3316G4R	16.3316B9R	16.3316R6R
	5	1	16.3416G4R	16.3416B9R	16.3416R6R
32	3	1	16.3232G4R	16.3232B6R	25737
	4	1	16.3332G4R	16.3332B9R	16.3332R6R
	5	1	16.3432G4R	16.3432B9R	16.3432R6R



Ref. / Item 25721



- Bloqueo conexión mecánico:
 - Después del conexionado de la clavija y puesto el swich en ON, la clavija queda bloqueada
 - Después de puesto el swich en OFF y extraída la clavija, el mando queda bloqueado.
- Mechanical interlocked:
 - After plugging and switching-on the plug is locked.
 - After switching-off and unplugging switch is locked.

En posición ON o OFF del mando es posible de poner candado por seguridad
At switch ON or OFF position, its possible to be lockable by padlock



BASES INTERBLOCANTES SUPERFICIE CON CARRIL DIN / SWITCHED INTERLOCKED WALL MOUNTED SOCKET WITH DIN RAIL

SpeedPRO IP44

base interbloqueante superficie con carril DIN / switched interlocked wall mounted socket with DIN rail

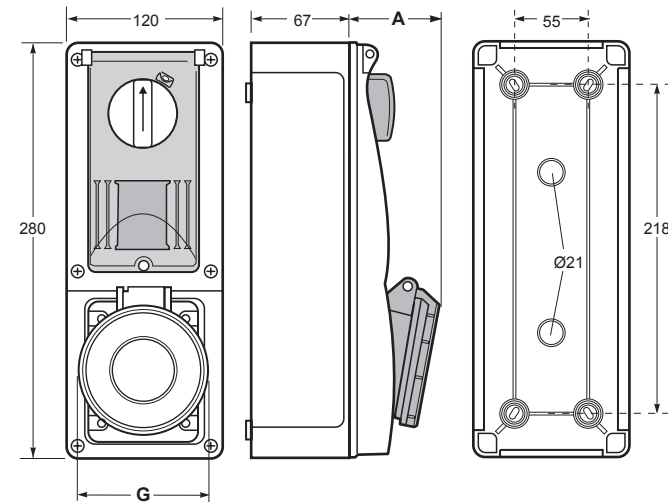

Poles	16A			32A		
	3	4	5	3	4	5
A	64	66,5	67	72,5	72,5	73,5
G	60	68	76	81	81	89
Connection type	Conexión por tornillo / Screw terminals					
Wire flexible (mm ²)	1 - 2,5			2,5 - 6		
Weight (g)	980	994	1070	995	1008	1090

- Terminales con tornillo
- Material: PA6/ABS
- Contactos: Niquelados
- Bloqueo conexionado mecánico
- Con carril DIN de 4 módulos y ventana abatible

IP44 a prueba de salpicaduras

- Si se quiere pedir con portafusible 10.3x38 50/60Hz, añadimos *FH, ej. 26306FH
- Si se quiere pedir con Magneto-térmico curva C reactivable desde el exterior + Luz de aviso de línea, añadimos *MCB, ej. 26306MCB

- With screw terminals
- Housing material: PA6/ABS
- Contacts: Nickel-plated contacts
- Mechanical Interlocked
- With DIN-rail and hinged window for 4 modules

IP44 Splashproof

- If you want to order with Fuse Holder 10.3x38 50/60Hz, add *FH, eg. 26306FH
- If you want to order with MCB-Type C reactivable from the outside + Led warning light to signal the line connection, add *MCB, eg. 26306MCB

3P = 2P + T
4P = 3P + T
5P = 3P + T + N

Amp	Poles	Pack unit	110V	230V	400V
			50/60Hz	50/60Hz	50/60Hz
			Poles: 3P 4P 5P Hour P: 4h 4h 4h	Poles: 3P 4P 5P Hour P: 6h 9h 9h	Poles: 3P 4P 5P Hour P: 9h 6h 6h

16	3	1	16.3214G4D	16.3214B6D	26334
	4	1	16.3314G4D	16.3314B9D	16.3314R6D
	5	1	26330	16.3414B9D	16.3414R6D

32	3	1	16.3234G4D	16.3234B6D	26335
	4	1	16.3414G4D	16.3334B9D	16.3334R6D
	5	1	16.3434G4D	16.3434B9D	16.3434R6D

Versión de RCD (30mA) disponible / RCD (30mA) version available

Para una versión de RCD transponga el 'D' para un 'R', p. 16.3214G4D es 16.3214G4R
For a RCD version transpose the 'D' for an 'R' e.g. 16.3214G4D is 16.3214G4R

Otras clasificaciones mA disponibles
Other mA ratings available



Ref. / Item 16.3214B6D



SpeedPRO IP67

base interbloqueante superficie con carril DIN / switched interlocked wall mounted socket with DIN rail

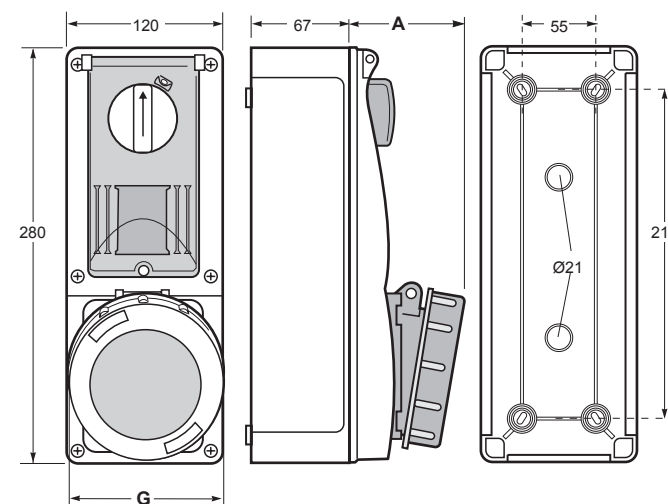

Poles	16A			32A		
	3	4	5	3	4	5
A	68	66,5	69	73,5	73,5	73,5
G	71	77	87	92	92	98
Connection type	Conexión por tornillo / Screw terminals					
Wire flexible (mm ²)	1 - 2,5			2,5 - 6		
Weight (g)	995	998	1085	1010	1018	1102

- Terminales con tornillo
- Material: PA6/ABS
- Contactos: Niquelados
- Bloqueo conexionado mecánico
- Con carril DIN de 4 módulos y ventana abatible

IP67 Hermético

- Si se quiere pedir con portafusible 10.3x38 50/60Hz, añadimos *FH, ej. 26320FH
- Si se quiere pedir con Magneto-térmico curva C reactivable desde el exterior + Luz de aviso de línea, añadimos *MCB, ej. 26320MCB

- With screw terminals
- Housing material: PA6/ABS
- Contacts: Nickel-plated contacts
- Mechanical Interlocked
- With DIN-rail and hinged window for 4 modules

IP67 Watertight

- If you want to order with Fuse Holder 10.3x38 50/60Hz, add *FH, eg. 26320FH
- If you want to order with MCB-Type C reactivable from the outside + Led warning light to signal the line connection, add *MCB, eg. 26320MCB

16	3	1	16.3216G4D	16.3216B6D	26336
	4	1	16.3316G4D	16.3316B9D	16.3316R6D
	5	1	16.3416G4D	16.3416B9D	16.3416R6D

32	3	1	16.3232G4D	16.3232B6D	26337
	4	1	16.3332G4D	16.3332B9D	16.3332R6D
	5	1	16.3432G4D	16.3432B9D	16.3432R6D

Versión de RCD (30mA) disponible / RCD (30mA) version available

Para una versión de RCD transponga el 'D' para un 'R', p. 16.3214G4D es 16.3214G4R
For a RCD version transpose the 'D' for an 'R' e.g. 16.3214G4D is 16.3214G4R

Otras clasificaciones mA disponibles
Other mA ratings available



Ref. / Item 16.3416R6D



- Bloqueo conexionado mecánico:
 - Después del conexionado de la clavija y puesto el switch en ON, la clavija queda bloqueada
 - Después de puesto el switch en OFF y extraída la clavija, el mando queda bloqueado.
- Mechanical interlocked:
 - After plugging and switching-on the plug is locked.
 - After switching-off and unplugging switch is locked.

En posición ON o OFF del mando es posible de poner candado por seguridad
At switch ON or OFF position, its possible to be lockable by padlock

SpeedPRO IP67

base interbloqueante superficie con carril DIN / switched interlocked wall mounted socket with DIN rail

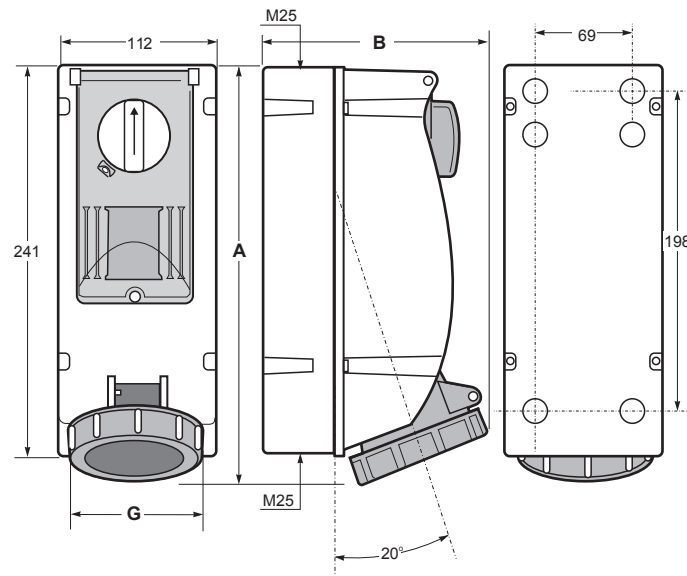

Poles	16A			32A		
	3	4	5	3	4	5
A	258	258	258	260	260	260
B	120	132	138	142	142	146
G	71	77	87	92	92	98
Connection type	Conexión por tornillo / Screw terminals					
Wire flexible (mm ²)	1 - 2,5			2,5 - 6		
Weight (g)	955	960	1030	965	971	1040

- Terminales con tornillo
- Material: PA6/ABS
- Contactos: Niquelados
- Bloqueo conexionado mecánico
- Con carril DIN de 4 módulos y ventana abatible

IP67 Hermético

- Si se quiere pedir con portafusible 10.3x38 50/60Hz, añadimos *FH, ej. 26506FH
- Si se quiere pedir con Magneto-térmico curva C reactivable desde el exterior + Luz de aviso de línea, añadimos *MCB, ej. 26506MCB

- With screw terminals
- Housing material: PA6/ABS
- Contacts: Nickel-plated contacts
- Mechanical Interlocked
- With DIN-rail and hinged window for 4 modules

IP67 Watertight

- If you want to order with Fuse Holder 10.3x38 50/60Hz, add *FH, eg. 26506FH
- If you want to order with MCB-Type C reactivable from the outside + Led warning light to signal the line connection, add *MCB, eg. 26506MCB

3P = 2P + T
4P = 3P + T
5P = 3P + T + N

110V
50/60Hz

230V
50/60Hz

400V
50/60Hz

500V
50/60Hz

Amp	Poles	Pack unit	Poles: 3P 4P 5P Hour P: 4h 4h 4h	Poles: 3P 4P 5P Hour P: 6h 9h 9h	Poles: 3P 4P 5P Hour P: 9h 6h 6h	Poles: 3P 4P 5P Hour P: 7h 7h 7h
-----	-------	-----------	-------------------------------------	-------------------------------------	-------------------------------------	-------------------------------------

16	3	1	17.216G4D	17.216B6D	26522	26524
	4	1	17.316G4D	17.316B9D	17.316R6D	26508
	5	1	17.416G4D	17.416B9D	17.416R6D	26509

32	3	1	17.232G4D	17.232B6D	26523	26525
	4	1	17.332G4D	17.332B9D	17.332R6D	26517
	5	1	17.432G4D	17.432B9D	17.432R6D	26518



Ref. / Item 26516



- Bloqueo conexionado mecánico:
 - Después del conexionado de la clavija y puesto el swich en ON, la clavija queda bloqueada
 - Después de puesto el swich en OFF y extraída la clavija, el mando queda bloqueado.
- Mechanical interlocked:
 - After plugging and switching-on the plug is locked.
 - After switching-off and unplugging switch is locked.

En posición ON o OFF del mando es posible de poner candado por seguridad
At switch ON or OFF position, its possible to be lockable by padlock



BASES INTERBLOCANTES DE SUPERFICIE 63A / SWITCHED INTERLOCKED WALL MOUNTED SOCKET 63A

SpeedPRO IP67

base interbloqueante superficie con carril DIN / switched interlocked wall mounted socket with DIN rail

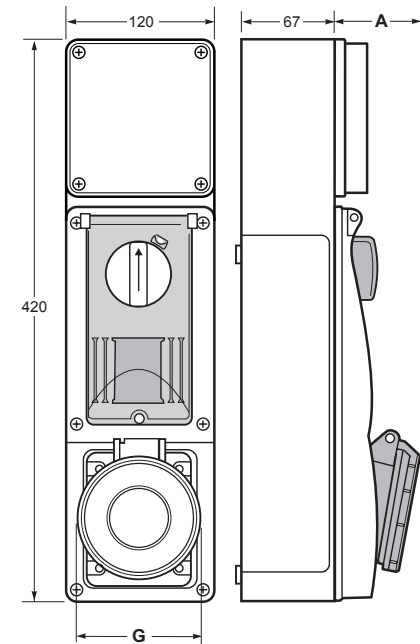

		63A		
Poles		3	4	5
A		88	88	88
G		111	111	111
Connection type		Conexión por tornillo / Screw terminals		
Wire flexible (mm ²)		6 - 16		
Weight (g)		1980	2010	2176

- Terminales con tornillo
- Material: PA6/ABS
- Contactos: Niquelados
- Bloqueo conexionado mecánico
- Con carril DIN de 4 módulos y ventana abatible

IP44 a prueba de salpicaduras

- Si se quiere pedir con portafusible 10.3x38 50/60Hz, añadimos *FH, ej. 26306FH
- Si se quiere pedir con Magneto-térmico curva C reactivable desde el exterior + Luz de aviso de línea, añadimos *MCB, ej. 26306MCB

- With screw terminals
- Housing material: PA6/ABS
- Contacts: Nickel-plated contacts
- Mechanical Interlocked
- With DIN-rail and hinged window for 4 modules

IP44 Splashproof

- If you want to order with Fuse Holder 10.3x38 50/60Hz, add *FH, eg. 26306FH
- If you want to order with MCB-Type C reactivable from the outside + Led warning light to signal the line connection, add *MCB, eg. 26306MCB

3P = 2P + T
4P = 3P + T
5P = 3P + T + N

110V
50/60Hz

230V
50/60Hz

400V
50/60Hz

500V
50/60Hz

Amp	Poles	Pack unit	Poles: 3P 4P 5P Hour P: 4h 4h 4h	Poles: 3P 4P 5P Hour P: 6h 9h 9h	Poles: 3P 4P 5P Hour P: 9h 6h 6h	Poles: 3P 4P 5P Hour P: 7h 7h 7h
-----	-------	-----------	-------------------------------------	-------------------------------------	-------------------------------------	-------------------------------------

63	3	1	16.263G4D	16.263B6D	25309	25316
	4	1	16.363G4D	16.363B6D	16.363R6D	25317
	5	1	16.463G4D	16.463B6D	16.463R6D	25318

Versión de RCD (30mA) disponible / RCD (30mA) version available

Para una versión de RCD transponga el 'D' para un 'MTR', p. 16.263G4D es 16.263G4MTR
For a RCD version transpose the 'D' for an 'MTR' e.g. 16.263G4D is 16.263G4MTR



Ref. / Item 16.463R6D



SpeedPRO IP67

base interbloqueante superficie con magnetotérmico / switched interlocked wall mounted socket with MCB

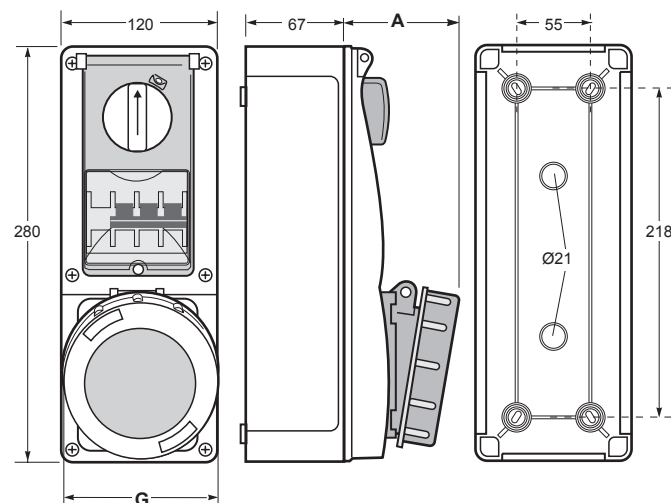

		63A		
Poles		3	4	5
A		88	88	88
G		111	111	111
Wire flexible (mm ²)		Conexión por tornillo / Screw terminals		
Weight (g)		6 - 15		
Weight (g)		1675	1780	1790

- Terminales con tornillo allen
- Material: PA6/ABS
- Contactos: Niquelados
- Bloqueo conexionado mecánico
- Con Magnetotérmico curva C reactivable desde el exterior + Luz de aviso de línea y ventana abatible

IP67 Hermético

- With screw terminals allen
- Housing material: PA6/ABS
- Contacts: Nickel-plated contacts
- Mechanical Interlocked
- MCB-Type C reactivable from the outside + Led warning light to signal the line connection, and hinged window

IP67 Watertight

63	3	1	25320	25323	25308	25326
	4	1	25321	25324	25306	25327
	5	1	25322	25325	25307	25328



Ref. / Item 25306



- Bloqueo conexionado mecánico:
 - Después del conexionado de la clavija y puesto el switch en ON, la clavija queda bloqueada
 - Después de puesto el switch en OFF y extraída la clavija, el mando queda bloqueado.
- Mechanical interlocked:
 - After plugging and switching-on the plug is locked.
 - After switching-off and unplugging switch is locked.

En posición ON o OFF del mando es posible de poner candado por seguridad
At switch ON or OFF position, its possible to be lockable by padlock

SpeedPRO IP67

base interbloqueante cuadro con magnetotérmico / switched interlocked panel socket with MCB

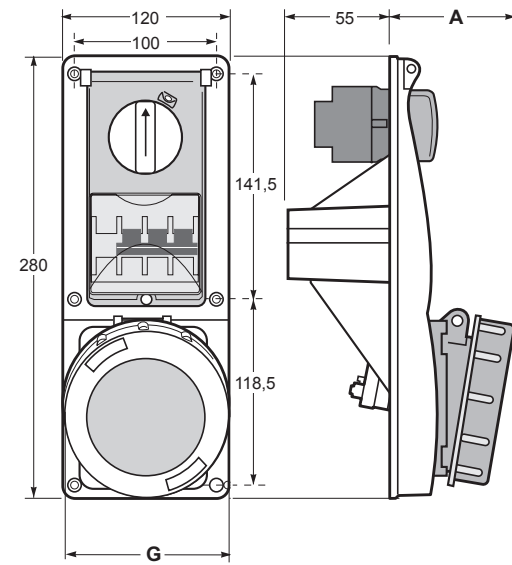

Poles	63A		
	3	4	5
A	88	88	88
G	111	111	111
Connection type	Conexión por tornillo / Screw terminals		
Wire flexible (mm ²)	6 - 16		
Weight (g)	1415	1520	1675

- Terminales con tornillo allen
- Material: PA6/ABS
- Contactos: Niquelados
- Bloqueo conexionado mecánico
- Con Magnetotérmico curva C reactivable desde el exterior + Luz de aviso de línea y ventana abatible

IP67 Hermético

- With screw terminals allen
- Housing material: PA6/ABS
- Contacts: Nickel-plated contacts
- Mechanical Interlocked
- MCB-Type C reactivable from the outside + Led warning light to signal the line connection, and hinged window

IP67 Watertight

3P = 2P + T
4P = 3P + T
5P = 3P + T + N

110V
50/60Hz

230V
50/60Hz

400V
50/60Hz

500V
50/60Hz

Amp	Poles	Pack unit	Poles: 3P 4P 5P Hour P: 4h 4h 4h	Poles: 3P 4P 5P Hour P: 6h 9h 9h	Poles: 3P 4P 5P Hour P: 9h 6h 6h	Poles: 3P 4P 5P Hour P: 7h 7h 7h
63	3	1	25330	25333	25208	25336
	4	1	25331	25334	25206	25337
	5	1	25332	25335	25207	25338



Ref. / Item 25206



- Bloqueo conexionado mecánico:
 - Después del conexionado de la clavija y puesto el swich en ON, la clavija queda bloqueada
 - Después de puesto el swich en OFF y extraida la clavija, el mando queda bloqueado.
- Mechanical interlocked:
 - After plugging and switching-on the plug is locked.
 - After switching-off and unplugging switch is locked.

En posición ON o OFF del mando es posible de poner candado por seguridad
At switch ON or OFF position, its possible to be lockable by padlock



SpeedPRO IP67
base interblocante superficie / switched interlocked wall mounted socket

3P = 2P + T
4P = 3P + T
5P = 3P + T + N

110V
50/60Hz

230V
50/60Hz

400V
50/60Hz

500V
50/60Hz

Amp	Poles	Pack unit	Poles: 3P 4P 5P Hour P: 4h 4h 4h	Poles: 3P 4P 5P Hour P: 6h 9h 9h	Poles: 3P 4P 5P Hour P: 9h 6h 6h	Poles: 3P 4P 5P Hour P: 7h 7h 7h
-----	-------	-----------	-------------------------------------	-------------------------------------	-------------------------------------	-------------------------------------

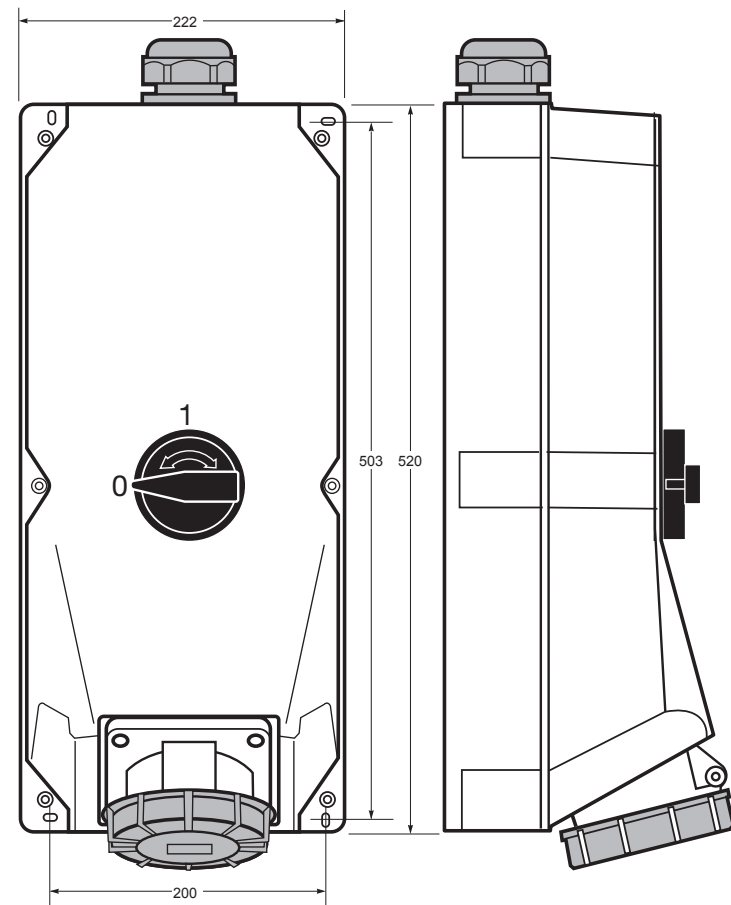

		125A		
Poles		3	4	5
Connection type	Conexión por tornillo / Screw terminals			
Cable gland M50	32 - 38 mm			

- Terminales con tornillo allen
- Material: PC/ABS
- Contactos: Latón
- Bloqueo conexionado mecánico
- Entrada superior

IP67 Hermético

- With screw terminals allen
- Housing material: PC/ABS
- Contacts: Brass
- Mechanical Interlocked
- Top entry

IP67 Watertight

125	3	1	9755102FAM	9755102	25158	25161
	4	1	25153	25156	9755099	25162
	5	1	25154	25157	9755100	25163



Ref. / Item 25159



- Bloqueo conexionado mecánico:
 - Después del conexionado de la clavija y puesto el swich en ON, la clavija queda bloqueada
 - Después de puesto el swich en OFF y extraída la clavija, el mando queda bloqueado.
- Mechanical interlocked:
 - After plugging and switching-on the plug is locked.
 - After switching-off and unplugging switch is locked.

En posición ON o OFF del mando es posible de poner candado por seguridad
At switch ON or OFF position, its possible to be lockable by padlock



3 TOMAS DE CORRIENTE DE CUADRO 50x50 PANEL SOCKETS OUTLETS 50x50

La gama de bases de cuadro 50 x 50 de Famatel, disponibles en IP54 y IP67, ofrece una lista amplia de soluciones al profesional, gracias en parte a sus diferentes posibilidades de cableado y su disponibilidad en diferentes sistemas de conexión (EU, FR, UK).

The range of Famatel 50 x 50 panel sockets, available in IP54 and IP67, offers a wide range of solutions to the professional user, thanks in part to their availability in different connection systems (EU, FR, UK).



- Nuevo diseño
- Protección IP54 - IP67
- Diferentes posibilidades de cableado
- Provisto de obturador

- New design
- IP54 - IP67 protection
- Different cabling options
- Child protection shutter



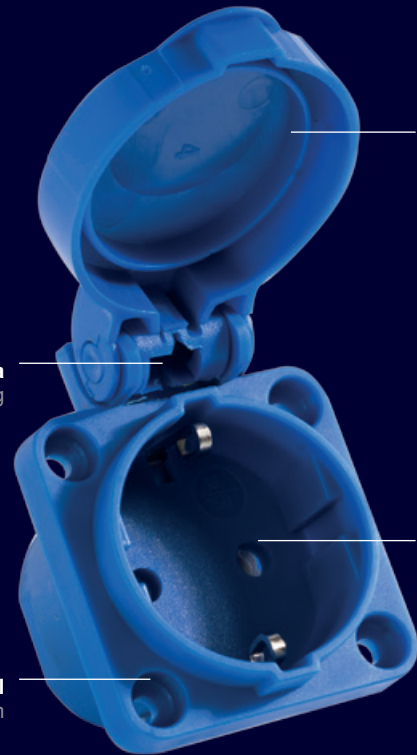

Carcasa y base de gran robustez
Robust housing construction

Muelle de alta Resistencia
High resistance spring

Obturador de seguridad infantil
Shutter child protection

Conexión por tornillo segura y profesional
Safe and profesional screw contact system

4 entradas de cable disponibles
4 cable entries available

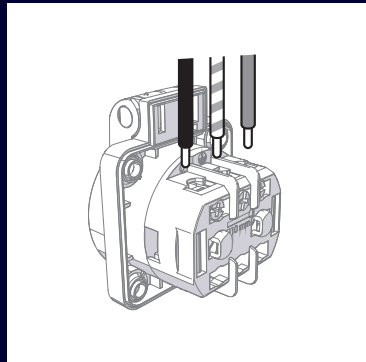

Conexión 1 lado vertical
Side vertical connector

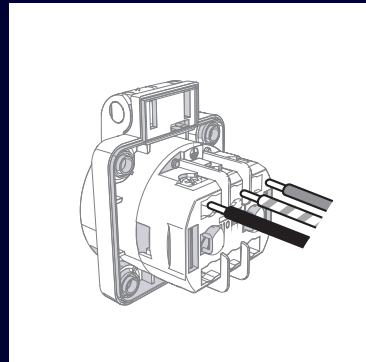

Conexión 1 lado horizontal simple
Side horizontal connector

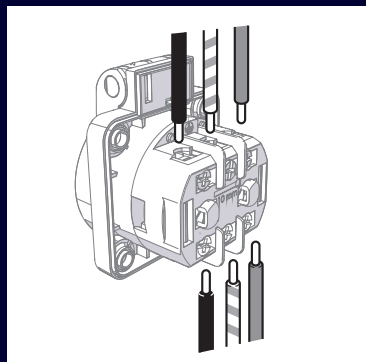

Conexión 2 lados vertical
Double vertical connector

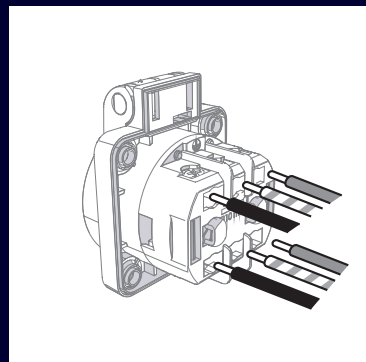

Conexión 2 lados horizontal
Double horizontal connector



Sistema alemán
German standard

Sistema francés
French standard

Sistema británico
British standard

TOMAS DE CORRIENTE 50x50 IP54
DIFERENTES CONEXIONES

IP54 SOCKET OUTLET 50x50 SIDE
DIFERENTS CONNECTIONS

Pg. 76



TOMA DE CORRIENTE BRITÁNICA
50x50 IP54

IP54 BRITISH SOCKET OUTLET 50x50

Pg. 76



TOMA DE CORRIENTE 55x55 IP67

IP67 SOCKET OUTLET 55x55

Pg. 77

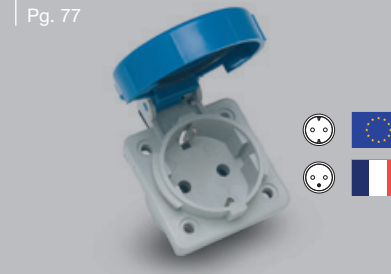

CLAVIJA - BASE AÉREA IP67

IP67 PLUG - SOCKET

Pg. 77



CAJAS SUPERFICIE PARA
TOMA DE CORRIENTE 50x50

SURFACE BOX FOR SOCKET
OUTLET 50x50

Pg. 77



PLACA ADAPTADORA PARA TOMA
DE CORRIENTE 50x50 Y 55x55

SOCKET COVER FOR OUTLET
50x50 AND 55x55

Pg. 77



3 TOMAS DE CORRIENTE DE CUADRO PANEL SOCKETS OUTLETS

TOMAS DE CUADRO IP54 / PANEL SOCKETS IP54 50x50

Tomas de cuadro IP54 / Panel sockets IP54

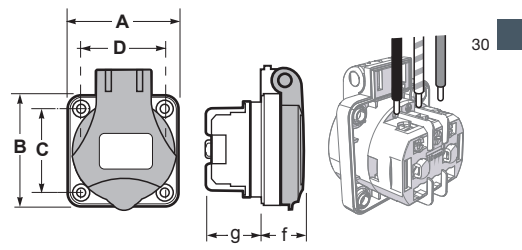

- Conexión 1 lado vertical
- Side vertical connection

Ref. / Item		13953
		13953F
16 A 2P+E polos / poles IP54		
Dimensions	A B C D f g	50 50 38 38 19,7 25,8
Connection type	Conexión por tornillo / Screw terminal	
Wire Flexible (mm ²)	1 - 2,5	
Weight (g)	47	

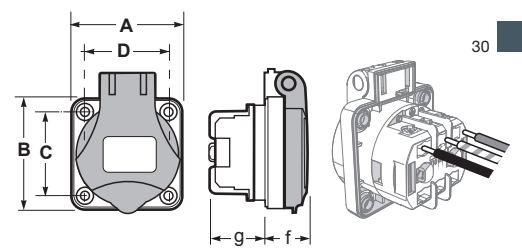

- Conexión 1 lado horizontal simple
- Side horizontal connection

Ref. / Item		13950
		13954F
16 A 2P+E polos / poles IP54		
Dimensions	A B C D f g	50 50 38 38 19,7 25,8
Connection type	Conexión por tornillo / Screw terminal	
Wire Flexible (mm ²)	1 - 2,5	
Weight (g)	47	

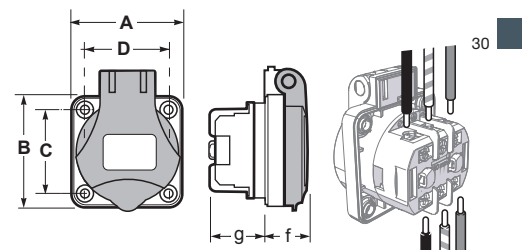

- Conexión 2 lados vertical
- Double vertical connection

Ref. / Item		13957
		13957F
16 A 2P+E polos / poles IP54		
Dimensions	A B C D f g	50 50 38 38 19,7 25,8
Connection type	Conexión por tornillo / Screw terminal	
Wire Flexible (mm ²)	1 - 2,5	
Weight (g)	47	

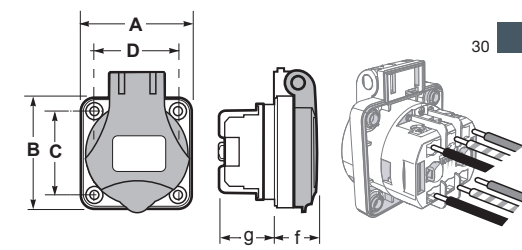

- Conexión 2 lados horizontal
- Double horizontal connection

Ref. / Item		13956
		13956F
16 A 2P+E polos / poles IP54		
Dimensions	A B C D f g	50 50 38 38 19,7 25,8
Connection type	Conexión por tornillo / Screw terminal	
Wire Flexible (mm ²)	1 - 2,5	
Weight (g)	47	

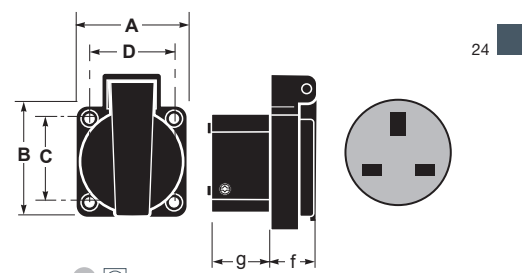

- Conexión 1 lado horizontal simple
- Side horizontal connection

Ref. / Item		13952
13 A 2P+E polos / poles IP54		
Dimensions	A B C D f g	50 50 38 38 17,5 24
Connection type	Conexión por tornillo / Screw terminal	
Wire Flexible (mm ²)	1 - 2,5	
Weight (g)	52	



TOMAS DE CUADRO IP67 / PANEL SOCKETS IP67 55x55

Tomas de cuadro IP67 / Panel sockets IP67

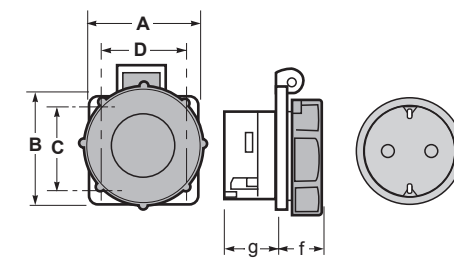

Ref. / Item		13960
16 A 2P+E polos / poles IP67		
Dimensions	A B C D f g	55 55 38 38 23,5 25,8
Connection type	Conexión por tornillo / Screw terminal	
Wire Flexible (mm ²)	1 - 2,5	
Weight (g)	76	

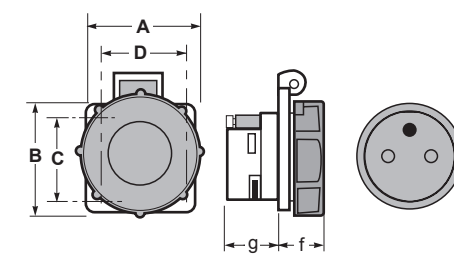

Ref. / Item		13960F
16 A 2P+E polos / poles IP67		
Dimensions	A B C D f g	55 55 38 38 23,5 25,8
Connection type	Conexión por tornillo / Screw terminal	
Wire Flexible (mm ²)	1 - 2,5	
Weight (g)	68	



Clavija - base aérea IP67 / Plug - Socket IP67

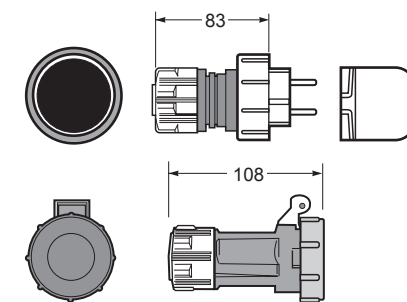

Ref. / Item		23960	Clavija aérea 16A 2P + TTL IP67 con doble contacto de tierra Schuko plug 16A 2P+E IP67
Ref. / Item		24960	Base aérea 16A 2P + TTL IP67 con doble contacto de tierra Schuko socket 16A 2P+E IP67
		24961	



Caja para tomas cuadro 50x50 / Box for panel sockets 50x50

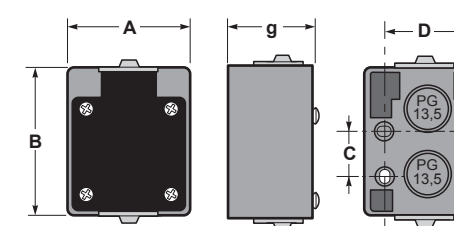

Ref. / Item		13955
Caja para mecanismos / box for mechanisms		
Dimensions	A B C D g	55 55 38 38 23,5
Weight (g)	52	

Incluye junta de goma / Include flange gasket

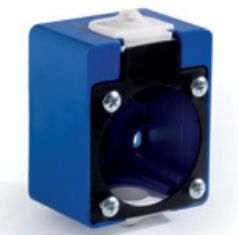

Adaptador para montar tomas 50x50 en armarios Acqua-Combi / Socket cover for panel socket 50x50 to mount in Acqua-Combi enclosures

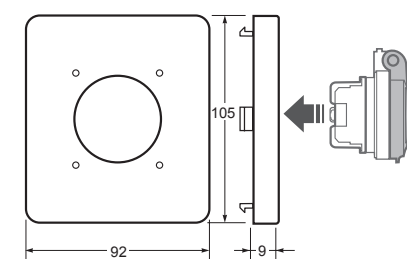

Ref. / Item		3905
Caja para mecanismos / box for mechanisms		
Weight (g)	35	



4 APLICACIONES ESPECIALES
SPECIAL APPLICATIONS

En Famatel ofrecemos 3 gamas especiales de tomas industriales destinadas para aquellos usos más específicos tales como eventos, contenedores en puerto o lugares con extrema conductividad. Las gamas de muy baja tensión, Container SpeedPRO y Eventos están diseñadas para su uso en estas aplicaciones.

In Famatel, we offer 3 special ranges of industrial plugs and sockets designed for those more specific uses such as events, containers in port or places with extreme conductivity. The very low voltage ranges, Container SpeedPRO and Events are designed for use in such applications.



Eventos
Events



Baja tensión
Low tension

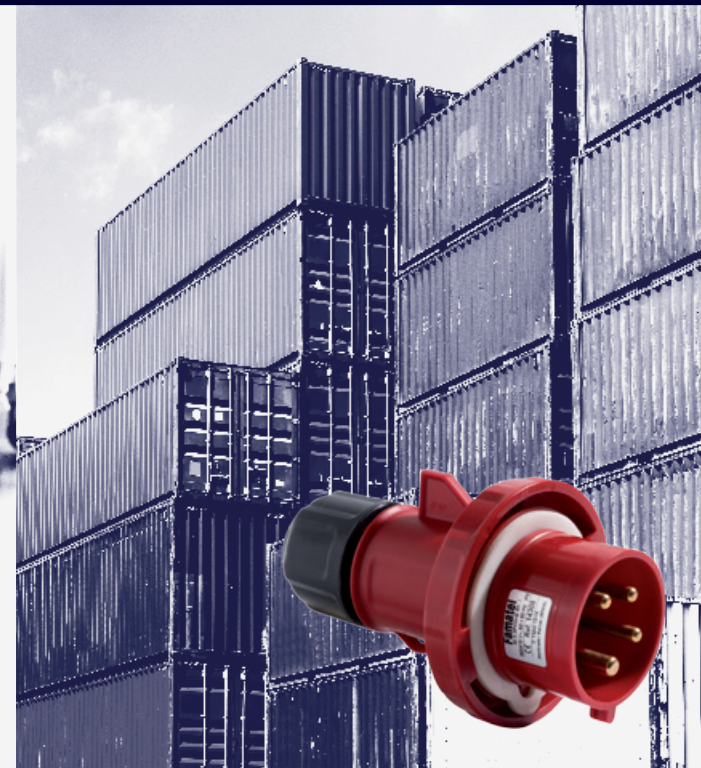

Contenedores
Containers



Proyecto terminal contenedores
Puerto Marsella
Loading terminal Marsella port project

- Gama especial para eventos
- Productos específicos a 3 h para terminales de carga
- Tomas y clavijas de bajísima tensión
- Special range for events
- Specific 3h products for loading terminals
- Low voltage plugs and sockets

4.1 CLAVIJAS Y BASES DE MUY BAJA TENSIÓN IP44/67
EXTRA LOW VOLTAGE PLUGS AND SOCKETS IP44/67



Usando la gama de bajo voltaje es la forma de una segura protección contra los choques eléctricos. Esta gama se utiliza en entornos donde hay un alto riesgo; piscinas, hospitales y entornos exteriores.

Using extra low voltage its a safety way to protect against electrical shock, extra low voltage is used where the risk is high; swimming pool, hospitals and outdoor applications.

4.2 CLAVIJAS Y BASES PARA CONTENEDORES SpeedPRO IP67
CONTAINER SpeedPRO PLUGS AND SOCKETS IP67



En entornos de atmósferas controladas nuestras tomas industriales juegan un papel determinante para asegurar el suministro eléctrico. Estas formas disponen de una configuración especial dadas las características de su entorno de trabajo. Configuradas en una posición horaria de 3h, protección IP67 y alta resistencia a los agentes externos..

In enviroments with controlled atmospheres our industrial sockets play a decisive role to ensure the electrical supply. These sockets have a special configuration given the characteristics of your working environment. Configured in a 3h time position, IP67 protection an high resistance to external agents.

4.3 CLAVIJAS Y BASES SpeepPRO IP44 Y EQUIPAMIENTO PARA EVENTOS
SpeedPRO PLUGS AND SOCKETS IP44 AND EVENT EQUIPMENT



Famatel pone a su disposición una gama completa de tomas industriales para su aplicación en eventos. Fabricadas en color negro y con una alta resistencia al impacto que las hace ideales para su aplicación a eventos.

Famatel has a wide range of industrial plugs and sockets for events. Manufactured in black colour with a very high resistance for the application on the events.

4.1

CLAVIJAS AÉREAS BAJA TENSIÓN IP44 / IP67

EXTRA-LOW VOLTAGE MOBILE PLUGS IP44 / IP67

Pg. 83



4.2

CLAVIJAS AÉREAS CONTENEDOR 3h IP67

CONTAINER PLUS 3H IP67

Pg. 90



4.3

CLAVIJAS AÉREAS EVENTOS IP44

MOBILE PLUGS FOR EVENTS IP44

Pg. 96



BASES AÉREAS BAJA TENSIÓN IP44 / IP67

EXTRA-LOW VOLTAGE MOBILE PLUGS IP44 / IP67

Pg. 85



BASES AÉREAS CONTENEDOR 3h IP67

CONTAINER SOCKETS 3h IP67

Pg. 90



BASES AÉREAS EVENTOS IP44

MOBILE SOCKETS FOR EVENTS IP44

Pg. 96



BASES DE CUADRO BAJA TENSIÓN IP44 / IP67

EXTRA-LOW VOLTAGE STRAIGHT PANEL SOCKETS IP44 / IP67

Pg. 87



BASES DE PARED Y CUADRO CONTENEDOR 3h IP67

CONTAINER WALL MOUNTED AND PANEL SOCKETS 3h IP67

Pg. 90



BASES DE CUADRO EVENTOS IP44

PANEL SOCKETS FOR EVENTS IP44

Pg. 96



BASES DE PARED BAJA TENSIÓN IP44 / IP67

EXTRA-LOW VOLTAGE WALL MOUNTED SOCKETS IP44 / IP67

Pg. 89



BASES INTERBLOCANTES CONTENEDOR 3h IP67

CONTAINER INTERLOCKED SOCKETS 3h IP67

Pg. 91



EQUIPAMIENTO PARA EVENTOS

EVENT EQUIPMENT

Pg. 97



Pg. 98



4.1 CLAVIJAS Y BASES DE MUY BAJA TENSIÓN IP44/67
EXTRA LOW VOLTAGE PLUGS AND SOCKETS IP44/67

CLAVIJAS DE MUY BAJA TENSIÓN / EXTRA LOW VOLTAGE PLUGS

SpeedPRO IP44
clavija aérea baja tensión / extra-low voltage mobile plug

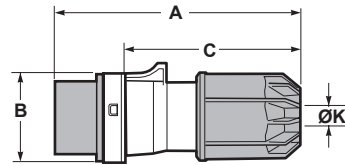

Poles	16A		32A	
	2	3	2	3
A	135	135	135	135
B	51	51	51	51
C	110	110	110	110
Ø K	9,5-24	9,5-24	9,5-24	9,5-24
Connection type	Conexión por tornillo / Screw terminals			
Wire flexible (mm²)	1 - 10		1 - 10	
Weight (g)	164	182	164	182

- Terminales con tornillo
- Materia: PA6
- Contactos: Niquelados
- IP44 a prueba de salpicaduras
- With screw terminals
- Housing material: PA6
- Contacts: Nickel-plated contacts
- IP44 Splashproof

Amp	Poles	Pack unit	20-25V 50/60Hz	40-50V 50/60Hz	20-25V 40-50V 100/200Hz	20-25V 40-50V DC
				Hour: 12h	Hour: 4h	Hour: 10h
16	2	10	13800	13900	13700	13600
	3	10	13801	13901	13701	13601
32	2	10	13820	13920	13720	13620
	3	10	13821	13921	13721	13621



Ref. / Item 13800



SpeedPRO IP67
clavija aérea baja tensión / extra-low voltage mobile plug

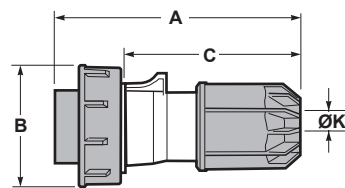

Poles	16A		32A	
	2	3	2	3
A	124	131	148	152
B	79	87	93	100
C	110	110	110	110
Ø K	9,5-24	9,5-24	9,5-24	9,5-24
Connection type	Conexión por tornillo / Screw terminals			
Wire flexible (mm²)	1 - 10		1 - 10	
Weight (g)	164	182	164	182

- Terminales con tornillo
- Material: PA6
- Contactos: Niquelados
- IP67 Hermético
- With screw terminals
- Housing material: PA6
- Contacts: Nickel-plated contacts
- IP67 Watertight

16	2	10	14800	14900	14700	14600
	3	10	14801	14901	14701	14601
32	2	10	14820	14920	14720	14620
	3	10	14821	14921	14721	14621



Ref. / Item 14800



Ej. Vista toma frontal
View; socket (front)

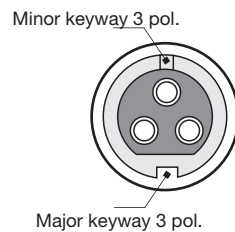

Para muy baja tensión la guía minor keyway es utilizada para distinguir el voltaje y la frecuencia.
For extra-low voltage a minor key is used to distinguish voltage and frequency-see table.

Rated Voltage - V	Frequency - Hz	Clockwise position		Colour acc. to EN 60309
		2P	3P	
20-25	50-60	without Minor key	without Minor key	Violet
40-50	50-60	12	12	White
	100-200	4	4	Green
20-25 and 40-50	300	2	2	Green *
	400	3	3	Green *
	> 400 - 500	11	11	Green *
	DC	10	10	White

* Solo bajo pedido / Available only upon request

- Esta gama está destinada a la solución de problemas de alimentación y de unión de circuitos con una tensión nominal de utilización de hasta 50V en instalaciones de lugares muy húmedos o con riesgo de incendios y explosiones.
- This range is used to solve problems of power supply or union of electrical circuits using a nominal voltage until 50V, using in conductive environment installations or with a high risk of fire or explosions.

4.1 CLAVIJAS Y BASES DE MUY BAJA TENSIÓN IP44/67
EXTRA LOW VOLTAGE PLUGS AND SOCKETS IP44/67

TOMAS DE MUY BAJA TENSIÓN / EXTRA LOW VOLTAGE SOCKETS

SpeedPRO IP44
base aérea baja tensión / extra-low voltage mobile socket

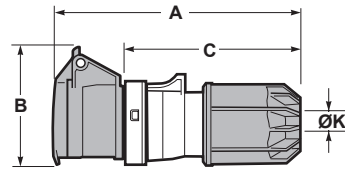

Poles	16A		32A	
	2	3	2	3
A	150	150	150	150
B	75	75	75	75
C	110	110	110	110
Ø K	9,5-24	9,5-24	9,5-24	9,5-24
Connection type	Conexión por tornillo / Screw terminals			
Wire flexible (mm ²)	1 - 10		1 - 10	
Weight (g)	179	199	179	199

- Terminales con tornillo
- Material: PA6
- Contactos: Niquelados
- IP44 a prueba de salpicaduras
- With screw terminals
- Housing material: PA6
- Contacts: Nickel-plated contacts
- IP44 Splashproof

Amp	Poles	Pack unit	20-25V 50/60Hz	40-50V 50/60Hz	20-25V 40-50V 100/200Hz	20-25V 40-50V DC
				Hour: 12h	Hour: 4h	Hour: 10h
16	2	10	23800	23900	23700	23600
	3	10	23801	23901	23701	23601
32	2	10	23820	23920	23720	23620
	3	10	23821	23921	23721	23621



Ref. / Item 23800



SpeedPRO IP67
base aérea baja tensión / extra-low voltage mobile socket

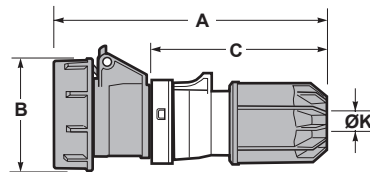

Poles	16A		32A	
	2	3	2	3
A	150	150	150	150
B	78	78	78	78
C	110	110	110	110
Ø K	9,5-24	9,5-24	9,5-24	9,5-24
Connection type	Conexión por tornillo / Screw terminals			
Wire flexible (mm ²)	1 - 10		1 - 10	
Weight (g)	199	219	199	219

- Terminales con tornillo
- Material: PA6
- Contactos: Niquelados
- IP67 Hermético
- With screw terminals
- Housing material: PA6
- Contacts: Nickel-plated contacts
- IP67 Watertight

Amp	Poles	Pack unit	20-25V 50/60Hz	40-50V 50/60Hz	20-25V 40-50V 100/200Hz	20-25V 40-50V DC
				Hour: 12h	Hour: 4h	Hour: 10h
16	2	10	24800	24900	24700	24600
	3	10	24801	24901	24701	24601
32	2	10	24820	24920	24720	24620
	3	10	24821	24921	24721	24621

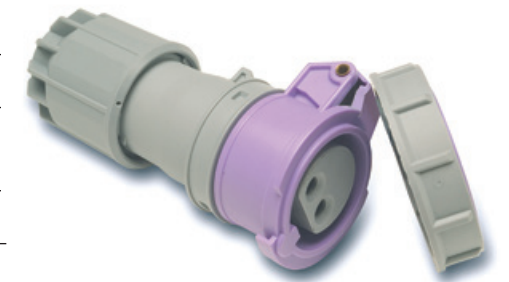

Ref. / Item 24800



Ej. Vista toma frontal
View; socket (front)

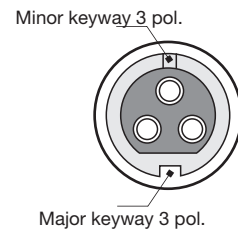

Para muy baja tensión la guía minor keyway es utilizada para distinguir el voltaje y la frecuencia.
For extra-low voltage a minor key is used to distinguish voltage and frequency-see table.

Rated Voltage - V	Frequency - Hz	Clockwise position		Colour acc. to EN 60309
		2P	3P	
20-25	50-60	without Minor key	without Minor key	Violet
40-50	50-60	12	12	White
	100-200	4	4	Green
20-25 and 40-50	300	2	2	Green *
	400	3	3	Green *
	> 400 - 500	11	11	Green *
	DC	10	10	White

* Solo bajo pedido / Available only upon request

- Esta gama está destinada a la solución de problemas de alimentación y de unión de circuitos con una tensión nominal de utilización de hasta 50V en instalaciones de lugares muy húmedos o con riesgo de incendios y explosiones.
- This range is used to solve problems of power supply or union of electrical circuits using a nominal voltage until 50V, using in conductive environment installations or with a high risk of fire or explosions.

4.1 CLAVIJAS Y BASES DE MUY BAJA TENSIÓN IP44/67
EXTRA LOW VOLTAGE PLUGS AND SOCKETS IP44/67

BASES DE CUADRO DE MUY BAJA TENSIÓN / EXTRA LOW VOLTAGE STRAIGHT PANEL SOCKETS

SpeedPRO IP44 75x85

base de cuadro baja tensión / extra-low voltage straight panel socket

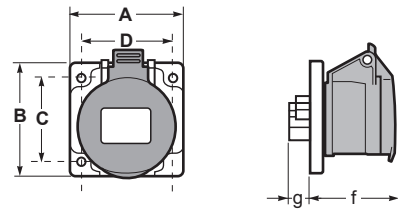

Poles	16A		32A	
	2	3	2	3
A	75	75	75	75
B	85	85	85	85
C	60	60	60	60
D	60	60	60	60
f	47	47	47	47
g	20	20	20	20
Connection type	Conexión por tornillo / Screw terminals			
Wire flexible (mm²)	1 - 10		1 - 10	
Weight (g)	136	146	128	146

- Terminales con tornillo
- Material: PA6
- Contactos: Niquelados
- IP44 a prueba de salpicaduras
- With screw terminals
- Housing material: PA6
- Contacts: Nickel-plated contacts
- IP44 Splashproof

Amp	Poles	Pack unit	20-25V	40-50V	20-25V	20-25V
			50/60Hz	50/60Hz	40-50V	40-50V
				Hour: 12h	Hour: 4h	Hour: 10h

16	2	2	25540	25544	25548	25552
	3	3	25541	25545	25549	25553
32	2	2	25542	25546	25550	25554
	3	3	25543	25547	25551	25555



Ref. / Item 25540



SpeedPRO IP67 75x85

base de cuadro baja tensión / extra-low voltage straight panel socket

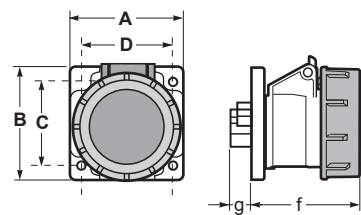

Poles	16A		32A	
	2	3	2	3
A	75	75	75	75
B	85	85	85	85
C	60	60	60	60
D	60	60	60	60
f	48	48	48	48
g	20	20	20	20
Connection type	Conexión por tornillo / Screw terminals			
Wire flexible (mm²)	1 - 10		1 - 10	
Weight (g)	145	165	145	165

- Terminales con tornillo
- Material: PA6
- Contactos: Niquelados
- IP67 Hermético
- With screw terminals
- Housing material: PA6
- Contacts: Nickel-plated contacts
- IP67 Watertight

16	2	2	25556	25560	25564	25568
	3	3	25557	25561	25565	25569
32	2	2	25558	25562	25566	25570
	3	3	25559	25563	25567	25571



Ref. / Item 25556



Ej. Vista toma frontal
View; socket (front)

Minor keyway 3 pol.

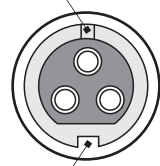

Major keyway 3 pol.

Para muy baja tensión la guía minor keyway es utilizada para distinguir el voltaje y la frecuencia.
For extra-low voltage a minor key is used to distinguish voltage and frequency-see table.

Rated Voltage - V	Frequency - Hz	Clockwise position		Colour acc. to EN 60309
		2P	3P	
20-25	50-60	without Minor key	without Minor key	Violet
40-50	50-60	12	12	White
	100-200	4	4	Green
20-25 and 40-50	300	2	2	Green *
	400	3	3	Green *
	> 400 - 500	11	11	Green *
	DC	10	10	White

* Solo bajo pedido / Available only upon request

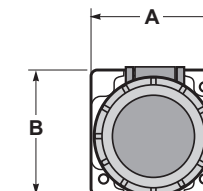

- Disponible en 54x60 (AxB), consultar
- Available in 54x60 (AxB), please consult

4.1 CLAVIJAS Y BASES DE MUY BAJA TENSIÓN IP44/67
EXTRA LOW VOLTAGE PLUGS AND SOCKETS IP44/67

BASES DE PARED DE MUY BAJA TENSIÓN / EXTRA LOW VOLTAGE WALL MOUNTED SOCKETS

SpeedPRO IP44
base de pared baja tensión / extra-low voltage wall mounted socket

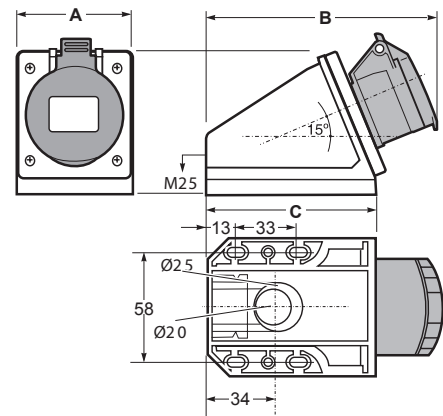

Poles	16A		32A	
	2	3	2	3
A	70,5	54	70,5	54
B	119	60	119	60
C	85	44	85	44
Connection type	Conexión por tornillo / Screw terminals			
Wire flexible (mm²)	1 - 10		1 - 10	
Weight (g)	109	130	109	130

- Terminales con tornillo
 - Material: PA6
 - Contactos: Niquelados
 - Incluye cono pasacable roscado
- IP44** a prueba de salpicaduras
- With screw terminals
 - Housing material: PA6
 - Contacts: Nickel-plated contacts
 - Include threaded grommet
- IP44** Splashproof

Amp	Poles	Pack unit	20-25V 50/60Hz	40-50V 50/60Hz	20-25V 40-50V 100/200Hz	20-25V 40-50V DC
			Hour: 12h	Hour: 4h	Hour: 10h	
16	2	10	23070	23075	23079	23082
	3	10	23072	23076	23080	23084
32	2	10	23073	23077	23081	23085
	3	10	23074	23078	23082	23086



Ref. / Item 23072



SpeedPRO IP67
base de pared baja tensión / extra-low voltage wall mounted socket

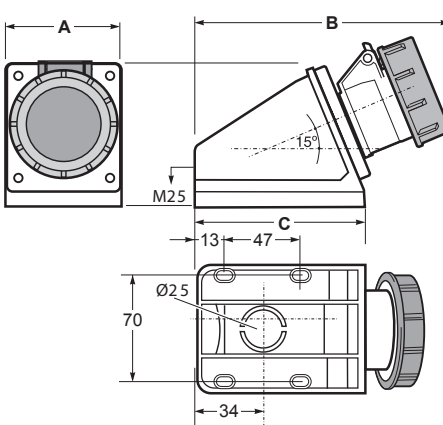

Poles	16A		32A	
	2	3	2	3
A	80	80	80	80
B	143	143	143	143
C	95	95	95	95
Connection type	Conexión por tornillo / Screw terminals			
Wire flexible (mm²)	1 - 10		1 - 10	
Weight (g)	231	251	231	251

- Terminales con tornillo
 - Material: PA6
 - Contactos: Niquelados
 - Incluye tapón roscado
- IP67** Hermético
- With screw terminals
 - Housing material: PA6
 - Contacts: Nickel-plated contacts
 - Include threaded bung
- IP67** Watertight

Amp	Poles	Pack unit	20-25V 50/60Hz	40-50V 50/60Hz	20-25V 40-50V 100/200Hz	20-25V 40-50V DC
			Hour: 12h	Hour: 4h	Hour: 10h	
16	2	10	24990	24994	24998	24982
	3	10	24991	24995	24999	24983
32	2	10	24992	24996	24980	24984
	3	10	24993	24997	24981	24985



Ref. / Item 24991



Ej. Vista toma frontal
View; socket (front)

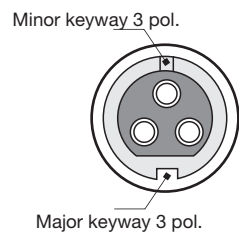

Para muy baja tensión la guía minor keyway es utilizada para distinguir el voltaje y la frecuencia.
For extra-low voltage a minor key is used to distinguish voltage and frequency-see table.

Rated Voltage - V	Frequency - Hz	Clockwise position		Colour acc. to EN 60309
		2P	3P	
20-25	50-60	without Minor key	without Minor key	Violet
40-50	50-60	12	12	White
20-25 and 40-50	100-200	4	4	Green
	300	2	2	Green *
	400	3	3	Green *
	> 400 - 500	11	11	Green *
	DC	10	10	White

* Solo bajo pedido / Available only upon request

- Esta gama está destinada a la solución de problemas de alimentación y de unión de circuitos con una tensión nominal de utilización de hasta 50V en instalación de lugares muy húmedos o con riesgo de incendios y explosiones.
- This range is used to solve problems of power supply or union of electrical circuits using a nominal voltage until 50V, using in conductive environment installations or with a high risk of fire or explosions.

Dimensiones en mm / Dimensions in mm

CLAVIJAS Y BASES IP67 / PLUGS AND SOCKETS IP67

Container SpeedPRO IP67
clavija aerea / mobile plug

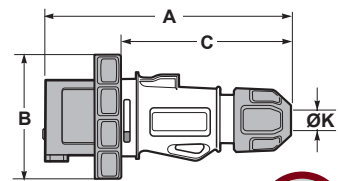

32A	
Poles	4
A	172
B	73
C	125
ØK	11,5-21
Connection type	Conexión por tornillo / Screw terminals
Wire flexible (mm²)	2,5 - 6
Weight (g)	123

- Terminales con tornillo
 - Material: PA6/ABS
 - Contactos: Latón
- IP67 Hermético
- With screw terminals
 - Housing material: PA6/ABS
 - Contacts: Brass
- IP67 Watertight



Container SpeedPRO IP67
base aerea / mobile socket

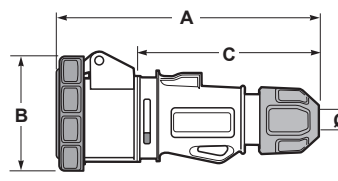

32A	
Poles	4
A	170
B	92
C	125
ØK	11,5-21
Connection type	Conexión por tornillo / Screw terminals
Wire flexible (mm²)	2,5 - 6
Weight (g)	315

- Terminales con tornillo
 - Material: PA6/ABS
 - Contactos: Niquelados
- IP67 Hermético
- With screw terminals
 - Housing material: PA6/ABS
 - Contacts: Nickel-plated contacts
- IP67 Watertight



Container SpeedPRO IP67 80x95
base de cuadro inclinada 10° / angled panel socket 10°

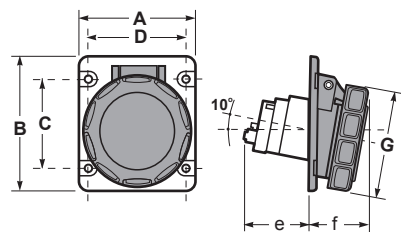

32A	
Poles	4
A	80
B	95
C	60
D	70
e	60
f	40
G	92
Connection type	Conexión por tornillo / Screw terminals
Wire flexible (mm²)	2,5 - 6
Weight (g)	215

- Terminales con tornillo
 - Material: PA6/ABS
 - Contactos: Niquelados
- IP67 Hermético
- With screw terminals
 - Housing material: PA6/ABS
 - Contacts: Nickel-plated contacts
- IP67 Watertight



Container SpeedPRO IP67
base de pared / wall mounted socket

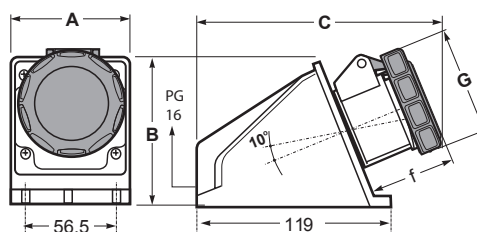

32A	
Poles	4
A	81
B	97
C	176
G	92
f	57
Connection type	Conexión por tornillo / Screw terminals
Wire flexible (mm²)	2,5 - 6
Weight (g)	335

- Terminales con tornillo
 - Material: PA6/ABS
 - Contactos: Niquelados
 - Entrada trasera
- IP67 Hermético
- With screw terminals
 - Housing material: PA6/ABS
 - Contacts: Nickel plated contacts
 - Rear entry
- IP67 Watertight



BASES INTERBLOCANTES IP67 VERTICALES / SWITCHED INTERLOCKED SOCKETS IP67 VERTICAL

Container SpeedPRO IP67
base interbloqueante cuadro vertical / switched interlocked panel socket vertical

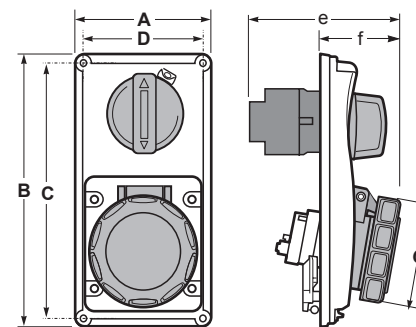

32A	
Poles	4
A	90
B	180
C	169
D	79
e	114
f	63
G	108
Connection type	Conexión por tornillo / Screw terminals
Wire flexible (mm²)	2,5 - 6
Weight (g)	455

- Terminales con tornillo
 - Material: PA6/ABS
 - Contactos: Niquelados
 - Bloqueo conexionado mecánico
- IP67 Hermético
- With screw terminals
 - Housing material: PA6/ABS
 - Contacts: Nickel-plated contacts
 - Mechanical interlocked
- IP67 Watertight



Ref. / Item	Pack unit.
25053	1



Container SpeedPRO IP67
base interbloqueante superficie vertical / switched interlocked wall mounted socket vertical

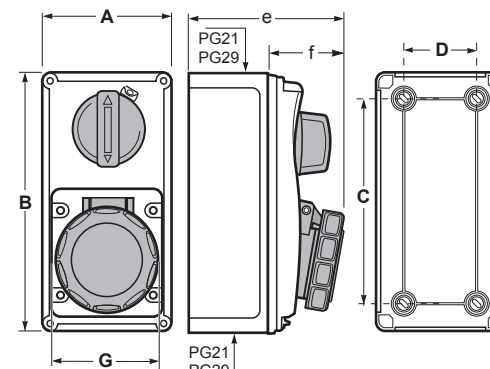

32A	
Poles	4
A	90
B	180
C	169
D	79
e	114
f	63
G	108
Connection type	Conexión por tornillo / Screw terminals
Wire flexible (mm²)	2,5 - 6
Weight (g)	455

- Terminales con tornillo
 - Material: PA6/ABS
 - Contactos: Niquelados
 - Bloqueo conexionado mecánico
- IP67 Hermético
- With screw terminals
 - Housing material: PA6/ABS
 - Contacts: Nickel-plated contacts
 - Mechanical interlocked
- IP67 Watertight



Ref. / Item	Pack unit.
26028	1



- Bloqueo conexionado mecánico:
 - Después del conexionado de la clavija y puesto el swich en ON, la clavija queda bloqueada
 - Después de puesto el swich en OFF y extraída la clavija, el mando queda bloqueado.
- Mechanical interlocked:
 - After plugging and switching-on the plug is locked.
 - After switching-off and unplugging switch is locked.

En posición ON o OFF del mando es posible de poner candado por seguridad
At switch ON or OFF position, its possible to be lockable by padlock



BASES INTERBLOCANTES HORIZONTALES IP67 / HORIZONTAL SWITCHED INTERLOCKED SOCKETS IP67

Container SpeedPRO IP67

base interbloqueante cuadro horizontal / switched interlocked panel socket horizontal

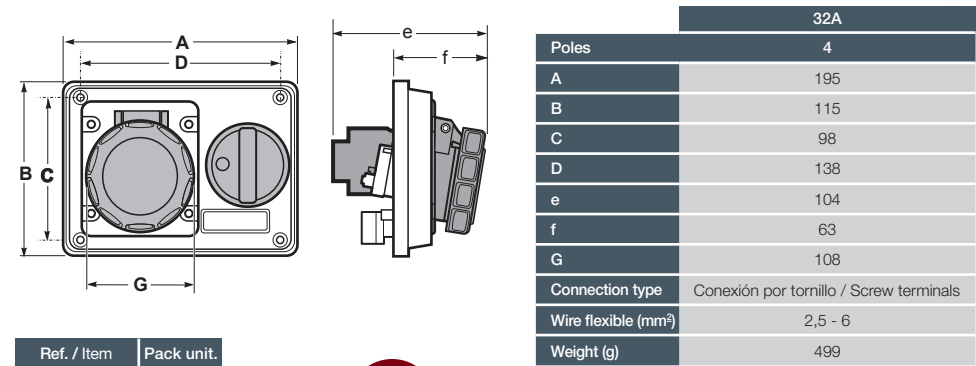

Ref. / Item	Pack unit.
25074	1

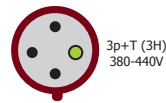

- Terminales con tornillo
- Material: PA6/ABS
- Contactos: Niquelados
- Bloqueo conexionado mecánico
- With screw terminals
- Housing material: PA6/ABS
- Contacts: Nickel-plated contacts
- Mechanical interlocked

IP67 Hermético

IP67 Watertight

Container SpeedPRO IP67

base interbloqueante superficie horizontal / switched interlocked wall mounted socket horizontal

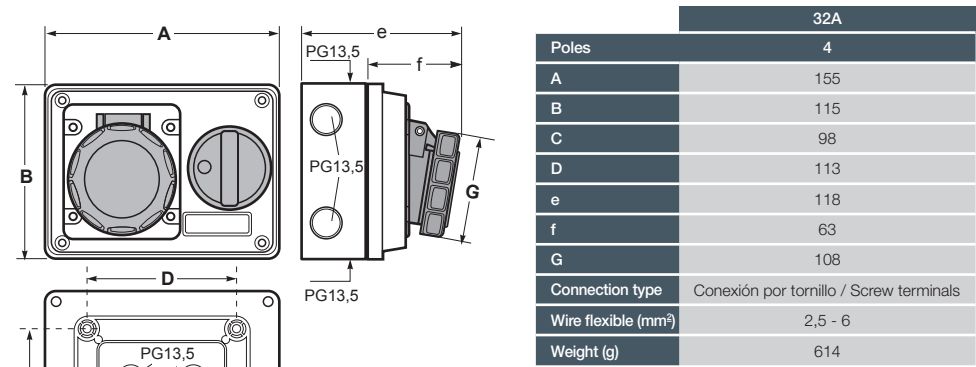

Ref. / Item	Pack unit.
25136	1

- Terminales con tornillo
- Material: PA6/ABS
- Contactos: Niquelados
- Bloqueo conexionado mecánico
- With screw terminals
- Housing material: PA6/ABS
- Contacts: Nickel-plated contacts
- Mechanical interlocked

IP67 Hermético

IP67 Watertight

• Bloqueo conexionado mecánico:

- Después del conexionado de la clavija y puesto el swich en ON, la clavija queda bloqueada
- Después de puesto el swich en OFF y extraida la clavija, el mando queda bloqueado.

• Mechanical interlocked:

- After plugging and switching-on the plug is locked.
- After switching-off and unplugging switch is locked.

En posición ON o OFF del mando es posible de poner candado por seguridad
At switch ON or OFF position, its possible to be lockable by padlock



BASES INTERBLOCANTES CON CARRIL DIN / SWITCHED INTERLOCKED SOCKETS WITH DIN RAIL

Container SpeedPRO IP67

base interbloqueante cuadro con carril DIN / switched interlocked panel socket with DIN rail

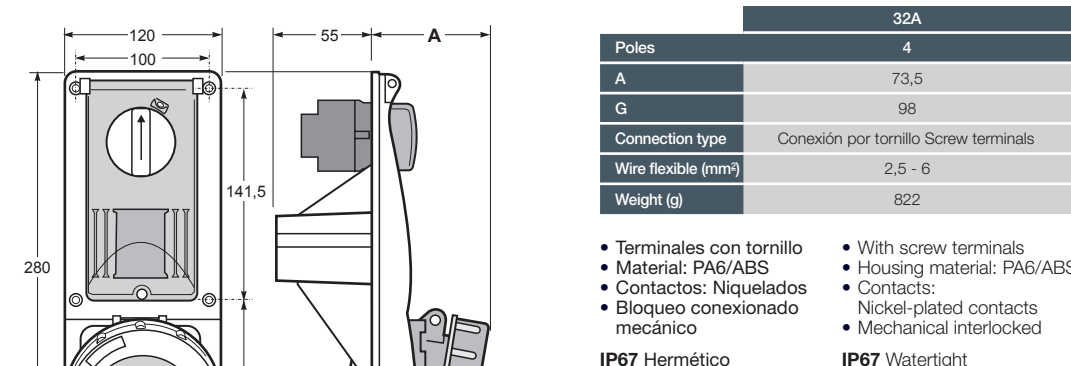

Ref. / Item	Pack unit.
25727	1

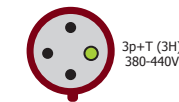

- Terminales con tornillo
- Material: PA6/ABS
- Contactos: Niquelados
- Bloqueo conexionado mecánico
- With screw terminals
- Housing material: PA6/ABS
- Contacts: Nickel-plated contacts
- Mechanical interlocked

IP67 Hermético

IP67 Watertight

- Si se quiere pedir con portafusible 10.3x38 50/60Hz, añadimos *FH, ej. 25727FH
- If you want to order with Fuse Holder 10.3x38 50/60Hz, add *FH, eg. 25727FH

- Si se quiere pedir con Magnetotérmico curva C reactivable desde el exterior + Luz de aviso de linea, añadimos *MCB, ej. 25727MCB
- If you want to order with MCB-Type C reactivable from the outside + Led warning light to signal the line connection, add *MCB, eg. 25727MCB

Container SpeedPRO IP67

base interbloqueante superficie vertical / switched interlocked wall mounted socket vertical

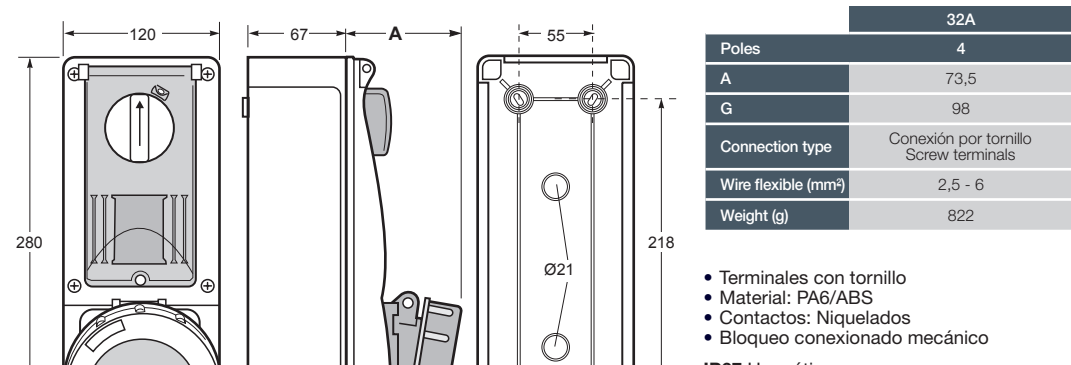

Ref. / Item	Pack unit.
26327	1

- Terminales con tornillo
- Material: PA6/ABS
- Contactos: Niquelados
- Bloqueo conexionado mecánico

IP67 Hermético

IP67 Watertight

- With screw terminals
- Housing material: PA6/ABS
- Contacts: Nickel-plated contacts
- Mechanical interlocked

- Si se quiere pedir con portafusible 10.3x38 50/60Hz, añadimos *FH, ej. 26327FH
- If you want to order with Fuse Holder 10.3x38 50/60Hz, add *FH, eg. 26327FH

- Si se quiere pedir con Magnetotérmico curva C reactivable desde el exterior + Luz de aviso de linea, añadimos *MCB, ej. 26327MCB
- If you want to order with MCB-Type C reactivable from the outside + Led warning light to signal the line connection, add *MCB, eg. 26327MCB

• Bloqueo conexionado mecánico:

- Después del conexionado de la clavija y puesto el swich en ON, la clavija queda bloqueada
- Después de puesto el swich en OFF y extraida la clavija, el mando queda bloqueado.

• Mechanical interlocked:

- After plugging and switching-on the plug is locked.
- After switching-off and unplugging switch is locked.

En posición ON o OFF del mando es posible de poner candado por seguridad
At switch ON or OFF position, its possible to be lockable by padlock



BASES INTERBLOCANTES CON CARRIL DIN / SWITCHED INTERLOCKED SOCKETS WITH DIN RAIL

Container SpeedPRO IP67

base interbloqueante superficie con carril DIN / switched interlocked wall mounted socket with DIN rail

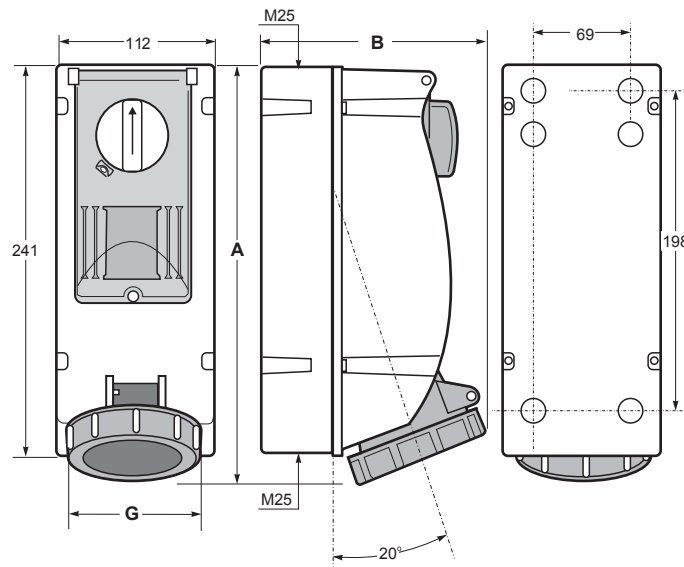

	32A
Poles	4
A	250
G	142
Connection type	Conexión por tornillo Screw terminals
Wire flexible (mm ²)	2,5 - 6
Weight (g)	971



Ref. / Item	Pack unit.
26514	1

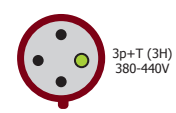

- Terminales con tornillo
 - Material: PA6/ABS
 - Contactos: Niquelados
 - Bloqueo conexionado mecánico
 - Con carril DIN de 4 módulos y ventana abatible
 - IP67 Hermético
- With screw terminals
 - Housing material: PA6/ABS
 - Contacts: Nickel-plated contacts
 - Mechanical interlocked
 - With DIN-rail and hinged window for 4 modules
 - IP67 Watertight

- Si se quiere pedir con portafusible 10.3x38 50/60Hz, añadimos *FH, ej. 26514FH
- If you want to order with Fuse Holder 10.3x38 50/60Hz, add *FH, eg. 26514FH
- Si se quiere pedir con Magnetotérmico curva C reactivable desde el exterior + Luz de aviso de línea, añadimos *MCB, ej. 26514MCB
- If you want to order with MCB-Type C reactivable from the outside + Led warning light to signal the line connection, add *MCB, eg. 26514MCB

- Bloqueo conexionado mecánico:
 - Después del conexionado de la clavija y puesto el swich en ON, la clavija queda bloqueada
 - Después de puesto el swich en OFF y extraída la clavija, el mando queda bloqueado.
- Mechanical interlocked:
 - After plugging and switching-on the plug is locked.
 - After switching-off and unplugging switch is locked.

En posición ON o OFF del mando es posible de poner candado por seguridad
At switch ON or OFF position, its possible to be lockable by padlock

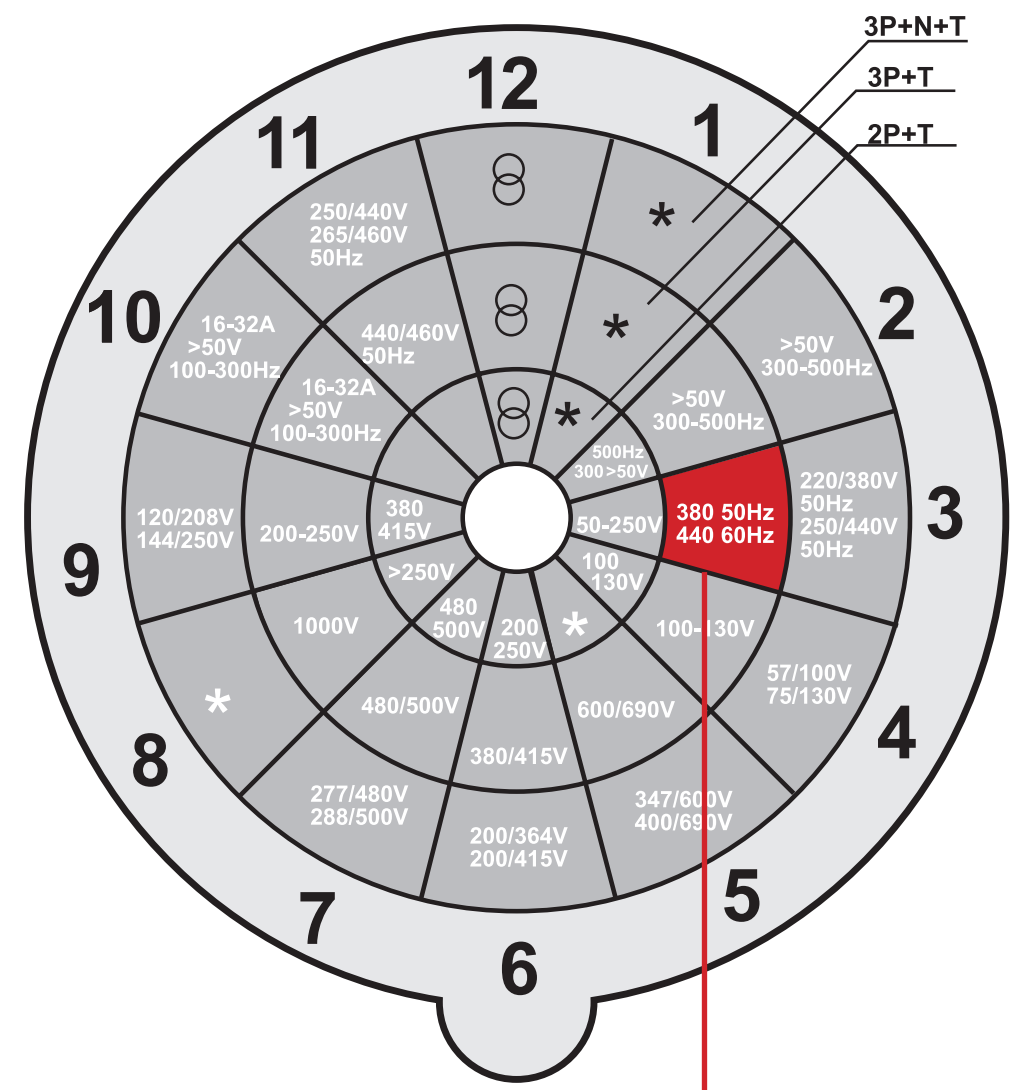

Aplicación Application	Posición horaria Position of the earthing contact
Contenedores refrigerados Reefer Container installations	h 3

CLAVIJAS Y BASES IP44 / PLUGS AND SOCKETS IP44

Eventos / Events **SpeedPRO IP44**
clavijas y bases aereas / mobile plugs and sockets

Clavija aerea / Mobile plug - Ref. Item **13410**

10

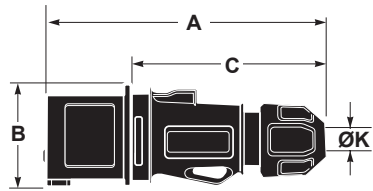

16A / 220/240V	
Poles	3
A	150
B	55
C	110
ØK	6-15
Connection type	Conexión por tornillo Screw terminals
Wire flexible (mm²)	1 -2,5
Weight (g)	123

Otros amperajes, voltaje o número de polos, consultar
Other Amperage, voltage or number of poles, please consult us

- Terminales con tornillo
- Material: PA6/ABS
- Contactos: Latón
- IP44 a prueba de salpicaduras
- With screw terminals
- Housing material: PA6/ABS
- Contacts: Brass
- IP44 Splashproof



Base aerea / Mobile socket - Ref. Item **23410**

10

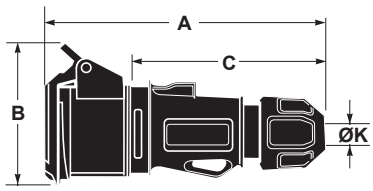

16A / 220/240V	
Poles	3
A	157
B	85
C	110
ØK	6-15
Connection type	Conexión por tornillo Screw terminals
Wire flexible (mm²)	1 -2,5
Weight (g)	215

Otros amperajes, voltaje o número de polos, consultar
Other Amperage, voltage or number of poles, please consult us

- Terminales con tornillo
- Material: PA6/ABS
- Contactos: Niquelados
- IP44 a prueba de salpicaduras
- With screw terminals
- Housing material: PA6/ABS
- Contacts: Nickel-plated contacts
- IP44 Splashproof



Base de cuadro / Panel socket - Ref. Item **23480**

10

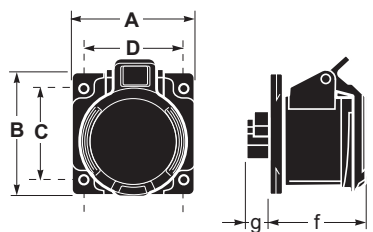

16A / 220/240V	
Poles	3
A	55
B	55
C	44
D	44
f	48
g	15
Connection type	Conexión por tornillo Screw terminals
Wire flexible (mm²)	1 -2,5
Weight (g)	138

Otros amperajes, voltaje o número de polos, consultar
Other Amperage, voltage or number of poles, please consult us

- Terminales con tornillo
- Material: PA6/ABS
- Contactos: Niquelados
- IP44 a prueba de salpicaduras
- With screw terminals
- Housing material: PA6/ABS
- Contacts: Nickel-plated contacts
- IP44 Splashproof



CLAVIJAS, BASES Y ADAPTADORES / PLUGS, SOCKETS AND ADAPTORS

Eventos / Events **IP44**

Eventos clavija / Event plug - Ref. Item **1106**

20

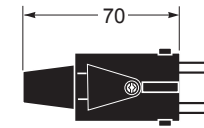

- Clavija bipolar en goma con TT lateral 16A/250V~, IP44
- Rubber plug with earth 16A/250V~, IP44



Eventos toma corriente / Event socket - Ref. Item **2106 - 2107**

20

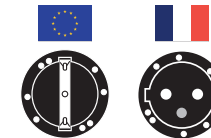
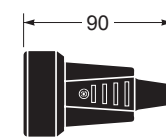

Ref. 2106 Ref. 2107

- Toma de corriente en goma con TT lateral 16A/250V~, IP44
- Trailing rubber socket with earth 16A/250V~, IP44



Eventos clavija / Event plug - Ref. Item **1107**

10

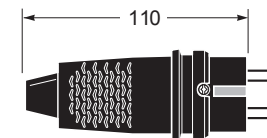

- Clavija bipolar en goma con doble contacto de tierra 16A/250V~, IP44
- Rubber plug with earth 16A/250V~, IP44



Eventos toma corriente / Event socket - Ref. Item **2108 - 2109**

10

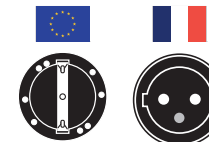
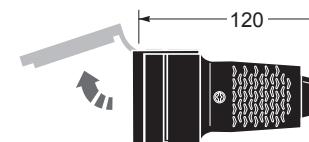

Ref. 2108 Ref. 2109

- Toma de corriente en goma con TT lateral 16A/250V~, IP44
- Trailing rubber socket with earth 16A/250V~, IP44



Eventos adaptador / Event adaptor - Ref. Item **187-G**

1

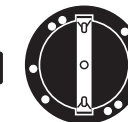
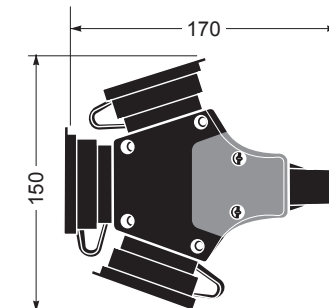

- Adaptador triple en goma con TT lateral 16A/250V~, IP44
- Triple rubber adaptor with earth 16A/250V~, IP44



Características generales / General characteristics

Color Colour	Resistencia al impacto Impact resistance	Grado autoextinguibilidad Auto-extinguishing degree	Estabilidad dimensional Dimensional stability	Hilo incandescente Glow wire test	Norma Norm
Negro Black	IK07	VO Autoextinguible Auto-extinguishing	- 25° + 85°	750°C partes activas, 650°C resto 750°C active parts, 650°C other parts	UNE 20315-2-5 UNE 20315-1-1 UNE 20315-1-2

4.3 CLAVIJAS Y BASES SpeepPRO IP44 Y EQUIPAMIENTO PARA EVENTOS
SpeedPRO PLUGS AND SOCKETS IP44 AND EVENT EQUIPMENT

CAJAS DE DISTRIBUCIÓN TERMOPLÁSTICAS / TERMOPLASTIC DISTRIBUTION BOXES

Caja vacía / Empty box 1

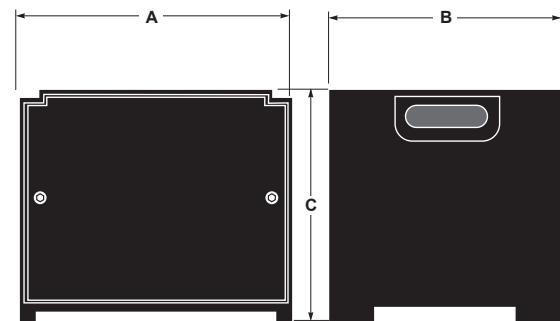

• Cajas móviles para la distribución de energía en eventos, ferias, eventos deportivos, cine y televisión

Ventajas

- Cajas extremadamente robustas fabricadas en Polietileno
- Ligeras y fáciles de trasladar
- Apilables

• Mobile boxes for the distribution of Energy in Events, fairs, sport events, film and television

Advantatges

- Extremely robust polyethylene housing
- Lightweight and easy to handle
- Stackable



Ref. / Item	Dimensions		
	A	B	C
39103	400	350	340
39104	560	350	340 *
39105	600	400	545 *
39106	600	400	670 *

* Posibilidad de instalar mecanismos en el panel frontal y trasero, los tornillos del panel frontal y trasero tienen rosca metálica, facilitando su extracción y colocación

* Possibility to mount devices in the frontal and rear panel, the screws of the front and rear panel have metal threads and may therefore be screwed in and out as often as required

Mirillas de maniobra IP66/67 / Hinged windows IP66/67

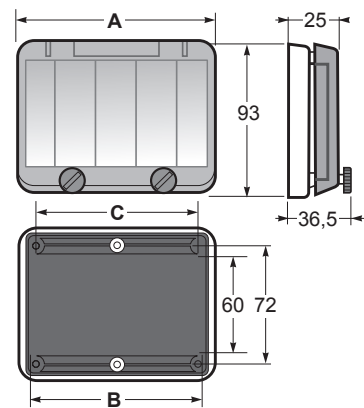

Mirillas de maniobra 2/4 módulos / Hinged window 2/4 modules

Ref. / Item	Módulos Modules	Dimensions			Peso Weight g	Pack unit.
		A	B	C		
23003	2	49	27	32	51	40
23004	4	85	65	72	80	20

Mirillas de maniobra 5/13 módulos / Hinged window 5/13 modules

Ref. / Item	Módulos Modules	Dimensions			Peso Weight g	Pack unit.
		A	B	C		
23005	5	103	41,5	90	90	20
23006	6	121	50,5	108	102	15
23007	7	139	59,5	126	114	15
23008	8	157	68,5	144	126	15
23009	9	175	77,5	162	133	15
23010	10	193	86,5	180	145	15
23011	12	229	104,5	215	168	10
23012	13	247	113,5	234	180	10

Mirillas de maniobra 18 módulos / Hinged window 18 modules

Ref. / Item	Módulos Modules	Dimensions			Peso Weight g	Pack unit.
		A	B	C		
23013	18	357	105	324	245	12

- * Posibilidad de montar mirillas en las cajas
- * Possibility to mount hinged windows in the boxes

ACCESORIOS / ACCESSORIES

Ref. / Item **1830** (Para/for 39103 / 39104)
1832 (Para/for 39105 / 39106)

- Taburete apilable galvanizado
- Galvanized stackable stool



Ref. / Item **1831** (Para/for 39105 / 39106)

- Chasis, 4 ruedas, 2 con freno
- Chassis, 4 wheels, 2 wheels with brake



CONFIGURACIÓN PERSONALIZADA / CUSTOM-MADE CONFIGURATION

1º

Elija el tipo de caja
Select the box

Apilable
Stackable

Superficie de mecanizado para mecanismos
Surface to mount devices

Ref. / Item	Dimensions	
	A	B
39103	300	250
39104	460	250 *
39105	500	300 *
39106	500	300 *

* Posibilidad de instalar mecanismos en ambas caras
* Possibility to mount devices at both sides

2º

Selecione las tomas
Select the sockets

16A, 32A, 63A

3º

Selecione el nº de protecciones y su mirilla correspondiente
Select the protections devices and the suitable Hinged window

En 24 h tiene su presupuesto
Yo will receive the quotation in 24 h



5 ADAPTADORES INDUSTRIALES IP44 / IP67 INDUSTRIAL ADAPTORS IP44 / IP67

SpeedPRO

El resultado de la gama de adaptadores industriales Famatel es una amplia variedad de posibilidades gracias a sus múltiples combinaciones y diferentes sistemas de conexión. Fabricados con materiales altamente resistentes al impacto y efectos climatológicos, esta serie cumplirá las más altas exigencias del profesional.

The result of the Famatel range of industrial adapters is a wide variety of possibilities thanks to its multiple combination and different connection systems. Manufactured with materials highly resistant to impact and weather conditions, this series will meet the highest demands of the professional users.



- Carcasa fabricada en PA6 / ABS
- Provisto de colgador para su fijación
- Múltiples combinaciones
- House body made in PA6 / ABS
- Built-in-hanger in its body
- Multiple combinations

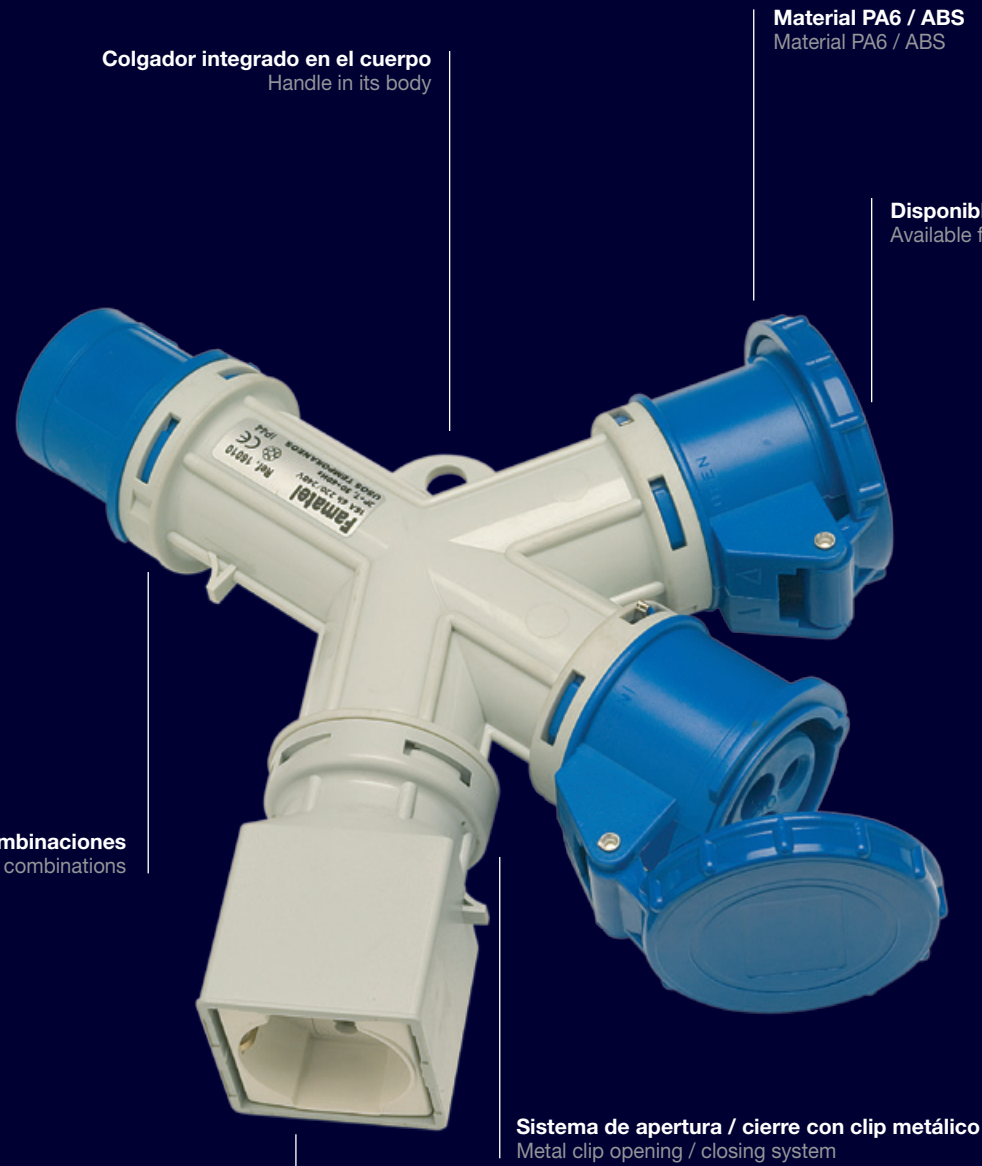

Colgador integrado en el cuerpo
Handle in its body

Material PA6 / ABS
Material PA6 / ABS

Disponible desde 110 a 500 V
Available from 110 to 500 V

Múltiples combinaciones
Multiple combinations

Sistema de apertura / cierre con clip metálico
Metal clip opening / closing system

Diferentes tipos de tomas
Different standards

ADAPTADORES
DOMÉSTICO-INDUSTRIAL IP20

DOMESTIC-INDUSTRIAL
ADAPTORS IP20

Pg. 104



ADAPTADORES MÚLTIPLES
DOMÉSTICO-INDUSTRIAL IP20

MULTIPLR DOMESTIC-INDUSTRIAL
ADAPTORS IP20

Pg. 105



ADAPTADORES INDUSTRIALES
MÚLTIPLES IP44 / IP67

MULTIPLE INDUSTRIAL ADAPTORS
IP44 / IP67

Pg. 107



ADAPTADORES INDUSTRIALES
MÚLTIPLES CON CABLE IP44 / IP67

MULTIPLE INDUSTRIAL ADAPTORS
IP44 / IP67 WITH CABLE

Pg. 113



ADAPTADORES INDUSTRIALES / INDUSTRIAL ADAPTORS

Adaptador doméstico-industrial IP20 / Domestic-industrial IP20

12

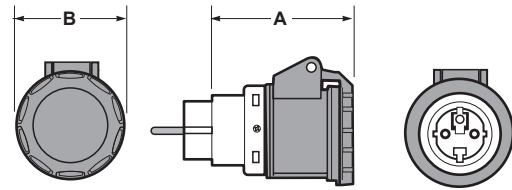

Ref. / Item		13912
Dimensions	A	B
Entrada / Entry	Clavija/plug schuko 16A/250V	
Salida / outlet	Toma/socket ind. CEE 16A/250V~2P+T 6h	
Weight (g)	164	



Adaptador industrial-doméstico IP20 / Industrial-Domestic IP20

12

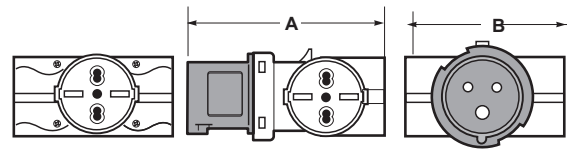

Ref. / Item		13913
Dimensions	A	B
Entrada / Entry	Clavija CEE /CEE plug16A/250V~ 2P+T 6h	
Salida / outlet	3 Tomas/sockets Bipasso 16A/250V	
Weight (g)	164	



Adaptador industrial-doméstico IP20 / Industrial-Domestic IP20

10

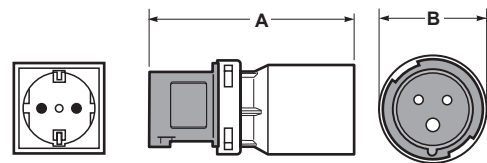

Ref. / Item		13910
Salida / outlet	Toma/socket schuko 16A/250V	
Ref. / Item		13910F
Salida / outlet	Toma/schucko FR 16A/250V	
Ref. / Item		13914
Salida / outlet	Toma/schucko UK 13A/250V	
Dimensions	A	B
Entrada / Entry	Clavija CEE /CEE plug16A/250V~ 2P+T 6h	
Weight (g)	154	



Adaptador industrial-doméstico IP44 / Industrial-domestic IP44

1

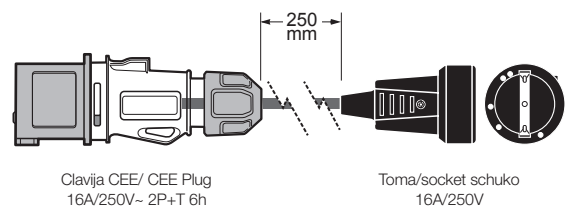

Ref. / Item	13000
• Adaptador industrial doméstico con prolongación IP44	
• Industrial-domestic adaptor cable extension IP44	



Adaptador industrial-doméstico IP44 / Industrial-domestic IP44

1

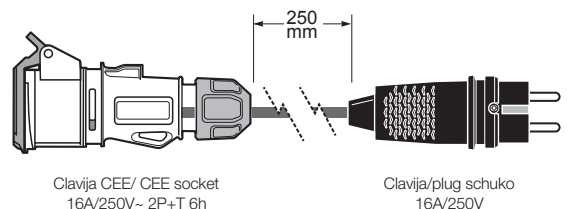

Ref. / Item	13011
• Adaptador industrial doméstico con prolongación IP44	
• Industrial-domestic adaptor cable extension IP44	



ADAPTADORES INDUSTRIALES MULTIPLES / MULTIPLE INDUSTRIAL ADAPTORS

Adaptador doméstico-industrial IP20 / Domestic-industrial IP20

2

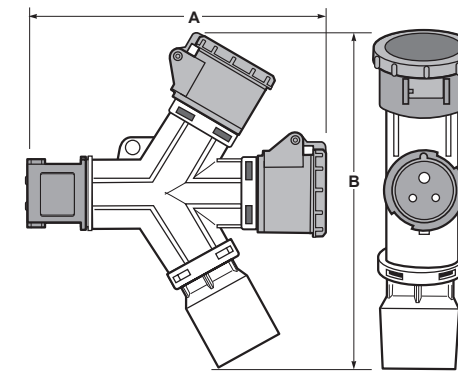

Ref. / Item		16010
Salida / outlet	2 ind. CEE 2P+T 16A/250V 6h + 1 schuko toma/socket 16A/250V	
Ref. / Item		16010F
Salida / outlet	2 ind. CEE 2P+T 16A/250V 6h + 1 schuko FR toma/socket 16A/250V	
Ref. / Item		16010E
Salida / outlet	2 ind. CEE 2P+T 16A/250V 6h + 1 UK toma/socket 13A/250V	
Dimensions	16A/250~2P+T	
	A	B
Entrada / Entry	Clavija CEE /CEE plug16A/250V~ 2P+T 6h	
Weight (g)	530	



Adaptador doméstico-industrial IP20 / Domestic-industrial IP20

4

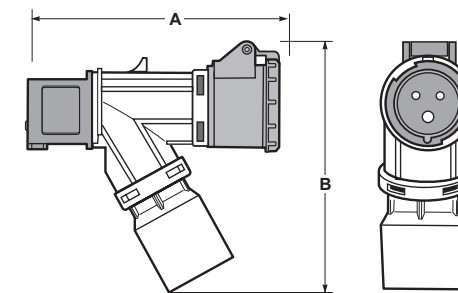

Ref. / Item		15002
Salida / outlet	1 ind. CEE 2P+T 16A/250V 6h + 1 schuko toma/socket 16A/250V	
Ref. / Item		15002F
Salida / outlet	1 ind. CEE 2P+T 16A/250V 6h + 1 schuko FR toma/socket 16A/250V	
Ref. / Item		15002E
Salida / outlet	1 ind. CEE 2P+T 16A/250V 6h + 1 UK toma/socket 13A/250V	
Dimensions	16A/250~2P+T	
	A	B
Entrada / Entry	Clavija CEE /CEE plug16A/250V~ 2P+T 6h	
Weight (g)	530	



ADAPTADORES INDUSTRIALES MÚLTIPLES / MULTIPLE INDUSTRIAL ADAPTORS

Adaptadores múltiples 3 tomas baja tensión IP44
Multiple adaptors low voltage 50/60 Hz IP44

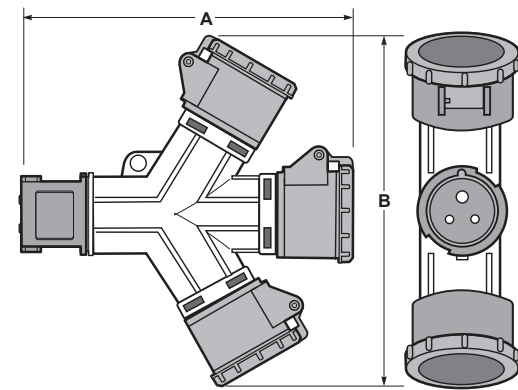

Dimensions		Amp	Polos Poles	Weight (g)
A	B			
225	220	16	2P + T	530
225	220	16	3P + T	563
225	220	16	3P + N + T	585
225	220	32	2P + T	605
225	220	32	3P + T	620
225	220	32	3P + N + T	678

3P = 2P + T
4P = 3P + T
5P = 3P + T + N

110V
50/60Hz

230V
50/60Hz

400V
50/60Hz

500V
50/60Hz

Amp	Poles	Pack unit	Poles: 3P 4P 5P Hour P: 4h 4h 4h	Poles: 3P 4P 5P Hour P: 6h 9h 9h	Poles: 3P 4P 5P Hour P: 9h 6h 6h	Poles: 3P 4P 5P Hour P: 7h 7h 7h
-----	-------	-----------	-------------------------------------	-------------------------------------	-------------------------------------	-------------------------------------

16	3	2	1401A	1402A	15020	15026
	4	2	15014	15021	15007	15027
	5	2	15015	15022	15008	15028
32	3	4	1407	1411	15023	15029
	4	4	15017	15024	15010	15030
	5	4	15018	15025	15009	15031



Ref. / Item 15006



Adaptadores múltiples 3 tomas baja tensión IP67
Multiple adaptors low voltage 50/60 Hz IP67

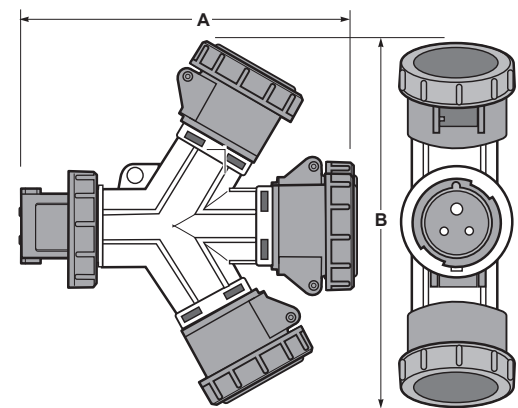

Dimensions		Amp	Polos Poles	Weight (g)
A	B			
285	280	16	2P + T	987
285	280	16	3P + T	995
285	280	16	3P + N + T	1010
285	280	32	2P + T	1018
285	280	32	3P + T	1035
285	280	32	3P + N + T	1075

16	3	2	16013	16002	16024	16026
	4	2	16014	16019	16003	16027
	5	2	16015	16020	16004	16028
32	3	4	1451	1461	16025	16029
	4	4	16017	16022	16009	16030
	5	4	16018	16023	16005	16031



Ref. / Item 16002



ADAPTADORES INDUSTRIALES MÚLTIPLES / MULTIPLE INDUSTRIAL ADAPTORS

Adaptadores múltiples 2 tomas baja tensión IP44
Multiple adaptors low voltage 50/60 Hz IP44

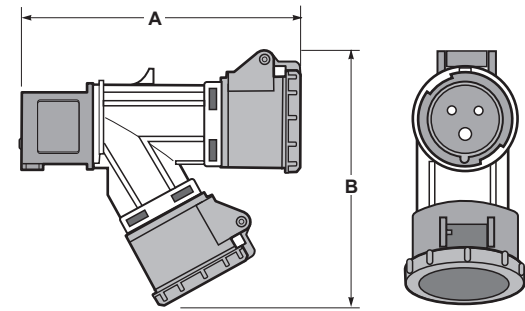

Dimensions		Amp	Polos Poles	Weight (g)
A	B			
160	168	16	2P + T	390
160	168	16	3P + T	450

3P = 2P + T
4P = 3P + T
5P = 3P + T + N

110V
50/60Hz

230V
50/60Hz

400V
50/60Hz

500V
50/60Hz

Amp	Poles	Pack unit	Poles: 3P 4P 5P Hour P: 4h 4h 4h	Poles: 3P 4P 5P Hour P: 6h 9h 9h	Poles: 3P 4P 5P Hour P: 9h 6h 6h	Poles: 3P 4P 5P Hour P: 7h 7h 7h
16	3	4	15032	15000	15036	15039
	4	4	15033	15037	15001	15040
	5	4	15034	15035	15038	15041



Ref. / Item 15001



Adaptadores múltiples 2 tomas baja tensión IP67
Multiple adaptors low voltage 50/60 Hz IP67

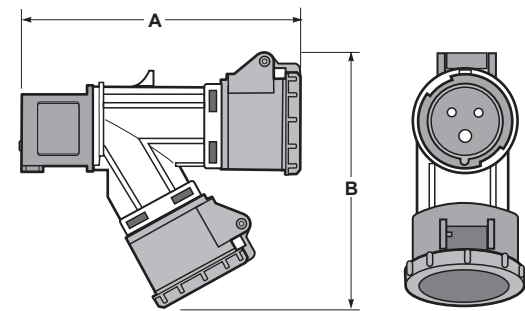

Dimensions		Amp	Polos Poles	Weight (g)
A	B			
170	162	16	2P + T	411
170	162	16	3P + T	470

Amp	Poles	Pack unit	Poles: 3P 4P 5P Hour P: 4h 4h 4h	Poles: 3P 4P 5P Hour P: 6h 9h 9h	Poles: 3P 4P 5P Hour P: 9h 6h 6h	Poles: 3P 4P 5P Hour P: 7h 7h 7h
16	3	4	16032	16000	16036	16039
	4	4	16033	16037	16001	16040
	5	4	16034	16035	16038	16041



Ref. / Item 16001



ADAPTADORES INDUSTRIALES MULTIPLES / MULTIPLE INDUSTRIAL ADAPTORS

Adaptadores múltiples 2 tomas baja tensión IP44
Multiple adaptors low voltage 50/60 Hz IP44

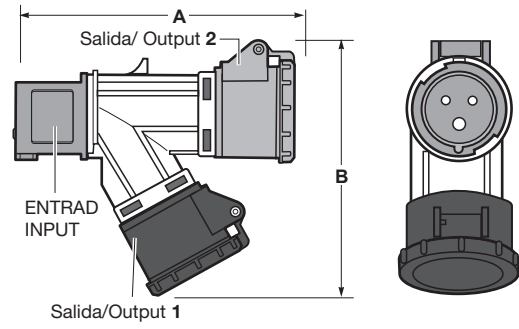

Dimensions		Amp	Polos Poles	Weight (g)
A	B			
160	168	16	2P + T	390
160	168	16	3P + T	450

		Entrada / Input: 400V Clavija / Plug 16A 3P+T+N 400 V IP44		
Amp	Pack unit	Adaptador industrial 2 salidas IP44 2 ways sockets industrial adaptor IP44		
Salida / Output 1		1 toma/socket 3P+T 400V	1 toma/socket 2P+T 230V	1 toma/socket 3P+T 400V
Salida / Output 2		1 toma/socket 2P+T 220V	1 toma/socket 2P+T 230V	1 toma/socket 3P+T 400V
16	4	15003	15004	15005



Ref. / Item 15003



Adaptadores múltiples 2 tomas baja tensión IP67
Multiple adaptors low voltage 50/60 Hz IP67

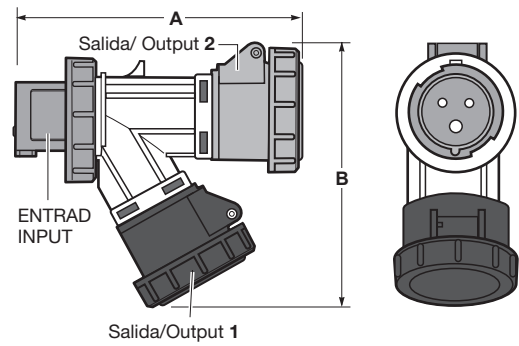

Dimensions		Amp	Polos Poles	Weight (g)
A	B			
170	162	16	2P + T	411
170	162	16	3P + T	470

		Entrada / Input: 400V Clavija / Plug 16A 3P+T+N 400 V IP67		
Amp	Pack unit	Adaptador industrial 2 salidas IP67 2 ways sockets industrial adaptor IP67		
Salida / Output 1		1 toma/socket 3P+T 400V	1 toma/socket 2P+T 230V	1 toma/socket 3P+T 400V
Salida / Output 2		1 toma/socket 2P+T 220V	1 toma/socket 2P+T 230V	1 toma/socket 3P+T 400V
16	4	16006	16007	16008



Ref. / Item 16006



ADAPTADORES INDUSTRIALES 2 SALIDAS / INDUSTRIAL ADAPTORS 2 WAYS

Adaptadores industriales 2 salidas IP44
Industrial adaptors 2 ways IP44

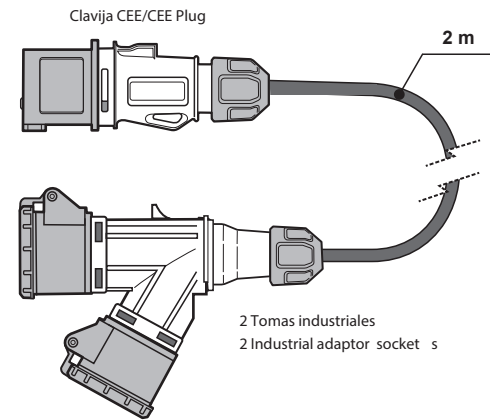

- Adaptador industrial 2 salidas con prolongación de 2 m de cable flexible y clavija IP44
- Industrial adaptor 2 ways with 2 m flexible cable anf plug IP44

Adaptadores industriales 2 salidas IP67
Industrial adaptors 2 ways IP67

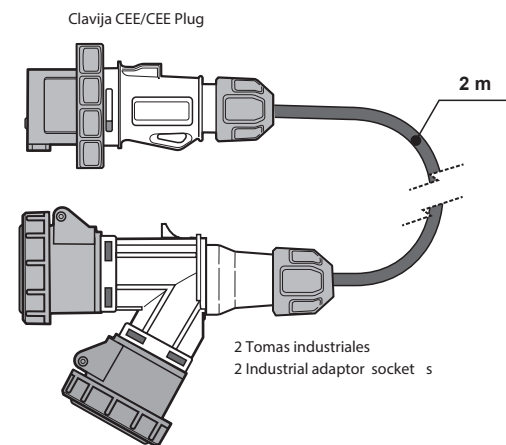

- Adaptador industrial 2 salidas con prolongación de 2 m de cable flexible y clavija IP67
- Industrial adaptor 2 ways with 2 m flexible cable anf plug IP67

3P = 2P + T
4P = 3P + T
5P = 3P + T + N

110V 50/60Hz	230V 50/60Hz	400V 50/60Hz	500V 50/60Hz
------------------------	------------------------	------------------------	------------------------

Amp	Poles	Pack unit	Poles: 3P 4P 5P Hour P: 4h 4h 4h	Poles: 3P 4P 5P Hour P: 6h 9h 9h	Poles: 3P 4P 5P Hour P: 9h 6h 6h	Poles: 3P 4P 5P Hour P: 7h 7h 7h
-----	-------	-----------	-------------------------------------	-------------------------------------	-------------------------------------	-------------------------------------

16	3	2	31002	31004	31063	31064
	4	2	31003	31005	31006	31007
	5	2	31065	31066	31067	31068



16	3	2	31008	31010	31069	31070
	4	2	31009	31011	31012	31013
	5	2	31071	31072	31073	31074



ADAPTADORES INDUSTRIALES 3 SALIDAS / INDUSTRIAL ADAPTORS 3 WAYS

Adaptadores industriales 3 salidas IP44
Industrial adaptors 3 ways IP44

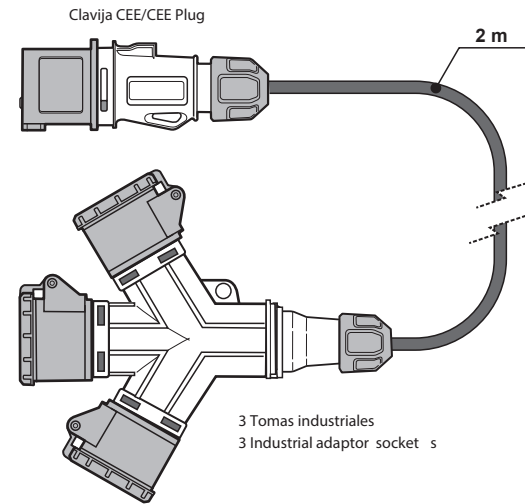

- Adaptador industrial 3 salidas con prolongación de 2 m de cable flexible y clavija IP44
- Industrial adaptor 3 ways with 2 m flexible cable anf plug IP44

Adaptadores industriales 3 salidas IP67
Industrial adaptors 3 ways IP67

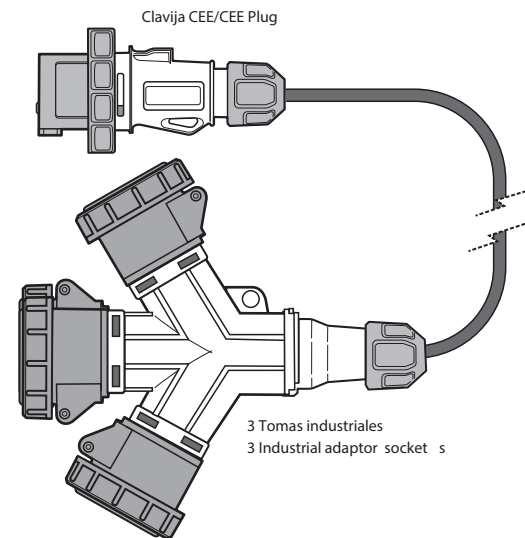

- Adaptador industrial 3 salidas con prolongación de 2 m de cable flexible y clavija IP67
- Industrial adaptor 3 ways with 2 m flexible cable anf plug IP67

3P = 2P + T
4P = 3P + T
5P = 3P + T + N

110V 50/60Hz	230V 50/60Hz	400V 50/60Hz	500V 50/60Hz
------------------------	------------------------	------------------------	------------------------

Amp	Poles	Pack unit	Poles: 3P 4P 5P Hour P: 4h 4h 4h	Poles: 3P 4P 5P Hour P: 6h 9h 9h	Poles: 3P 4P 5P Hour P: 9h 6h 6h	Poles: 3P 4P 5P Hour P: 7h 7h 7h
-----	-------	-----------	-------------------------------------	-------------------------------------	-------------------------------------	-------------------------------------

16	3	1	31044	31034	31054	31056
	4	1	31045	31035	31040	31050
	5	1	31046	31036	31041	31051
32	3	1	31047	31037	31055	31057
	4	1	31048	31038	31042	31052
	5	1	31049	31039	31043	31053



Ref. / Item 31040



16	3	1	31024	31014	31058	31060
	4	1	31025	31015	31020	31030
	5	1	31026	31016	31021	31031
32	3	1	31027	31017	31059	31062
	4	1	31028	31018	31022	31032
	5	1	31029	31019	31023	31033



Ref. / Item 31020





6 ENROLLACABLES INDUSTRIALES IP67 INDUSTRIAL CABLE REELS IP67

La gama de enrollacables industriales Famatel ofrece una solución industrial robusta y de calidad, perfecta para la industria, construcción y cualquier otro lugar en donde tomas con porteccción IP67 sean requeridas.

The Famatel range of industrial cablereels offers a quality and robust industrial solution perfects to the industry, constructions and any other place where the IP67 sockets are needed.



- Diseñado para entornos exigentes
 - Para su uso en ambientes exteriores IP67
 - Fácil transporte
 - Disponibles en diferentes configuraciones
- Designed for heavy duty use
 - Outdoor use IP67
 - Easy transport
 - Available in different configurations



Empuñadura fabricada en goma que facilita su portabilidad.

Handle with a rubber coating to assure a perfect portability.



Manivela para una perfecta manipulación.

Crank for a perfect handling.



Disyuntor térmico automático en caso de sobrecalentamiento.

Automatic cut-out.



Freno ajustable.

Adjustable brake for cable reeling.



Tomas industriales IP67 que garantiza la máxima seguridad en ambientes con mucho polvo y humedad.

Industrial IP67 plugs and sockets that guarantee the maximum security in harsh environments.



Salida de cable que facilita el bobinado.

Cable exit to help the cable reeling.

ENROLLACABLES INDUSTRIALES TOMAS SCHUKO IP67

IP 67 INDUSTRIAL CABLE REEL WITH SCHUKO SOCKETS

Pg. 120



ENROLLACABLES INDUSTRIALES TOMAS INDUSTRIALES IP67

IP67 INDUSTRIAL CABLE REEL WITH INDUSTRIAL SOCKETS

Pg. 120



ENROLLACABLES INDUSTRIALES TOMAS SCHUKO IP67 CON DIFERENCIAL MAGNETOTÉRMICO

IP67 INDUSTRIAL CABLE REEL WITH SCHUKO SOCKETS AND RCCB + MCB

Pg. 120



ENROLLACABLES INDUSTRIALES TOMAS SCHUKO IP67

IP67 INDUSTRIAL CABLE REEL WITH SCHUKO SOCKETS

Pg. 121



ENROLLACABLES IP67 / CABLE REEL IP67

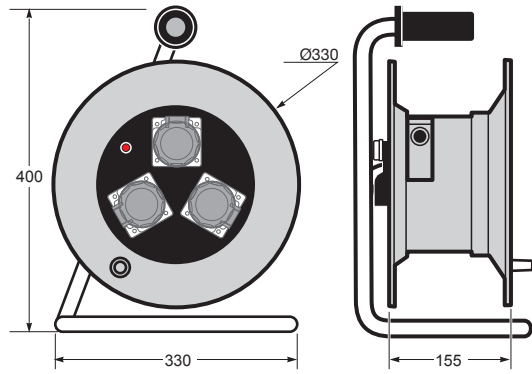

Ref. / Item	Cable	Clavija de entrada / Input plug	Tomas salida / Sockets outputs
30013	30 m H07RN-F 3 x 1,5 mm ²	Schuko IP67 2P+TTL 16A/250V IP67 schuko 2P+E 16/250V	4 Schuko IP67 2P+TTL 16A/250V 4 Schuko IP67 2P+E 16A/250V
30014	50 m H07RN-F 3 x 1,5 mm ²	Schuko IP67 2P+TTL 16A/250V IP67 schuko 2P+E 16/250V	4 Schuko IP67 2P+TTL 16A/250V 4 Schuko IP67 2P+E 16A/250V
30015	50 m H07RN-F 3 x 1,5 mm ²	Industrial CEE IP67 2P+T 16A/250V IP67 Industrial CEE 2P+E 16/250V	4 Schuko IP67 2P+TTL 16A/250V 4 Schuko IP67 2P+E 16A/250V
30016*	30 m H07RN-F 3 x 1,5 mm ²	Schuko IP67 2P+TTL 16A/250V IP67 schuko 2P+E 16/250V	3 Schuko IP67 2P+TTL 16A/250V 3 Schuko IP67 2P+E 16A/250V
30002	30 m H07RN-F 3 x 2,5 mm ²	Industrial CEE IP67 2P+T 16A/250V IP67 Industrial CEE 2P+E 16/250V	3 Industrial CEE IP67 2P+T 16A/250V 3 Industrial CEE IP67 2P+T 16A/250V
30004	30 m H07RN-F 4 x 2,5 mm ²	Industrial CEE IP67 3P+T 16A/380V IP67 Industrial CEE 3P+E 16/380V	3 Industrial CEE IP67 3P+T 16A/380V 3 Industrial CEE IP67 3P+T 16A/380V

Descripción: Enrollables con disyuntor
 • Grado de protección: **IP67**
 • Resistencia al impacto: **IK06**
 • Estabilidad dimensional: **-25°C +85°C**
 • Hilo incandescente: **750°C partes activas**
650°C otras partes
EN61242
 • Norma:

Description: Cable reel with safety cut out
 • Degree of protection: **IP67**
 • Impact resistance: **IK06**
 • Dimensional stability: **-25°C +85°C**
 • Glow wire test: **750°C active parts**
650°C other parts
EN61242
 • Norm:

Carga máxima / Max power		
	16A / 230V	1800 W
	16A / 400V	5500 W
	16A / 230V	3500 W
	16A / 400V	11000 W

ENROLLACABLES IP67 / CABLE REEL IP67

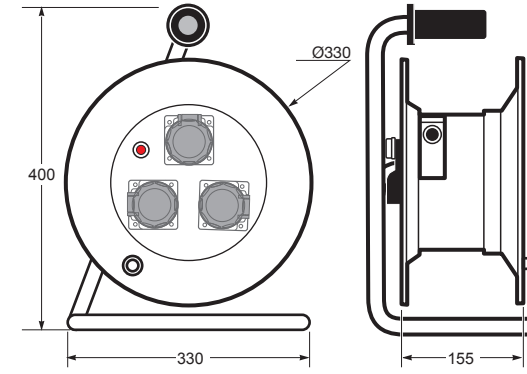

Ref. / Item	Cable	Clavija de entrada / Input plug	Tomas salida / Sockets outputs
30017	25 m H07RN-F 3 x 1,5 mm ²	Schuko IP67 2P+TTL 16A/250V IP67 schuko 2P+E 16/250V	3 Schuko IP67 2P+TTL 16A/250V 3 Schuko IP67 2P+E 16A/250V
30018	50 m H07RN-F 3 x 1,5 mm ²	Schuko IP67 2P+TTL 16A/250V IP67 schuko 2P+E 16/250V	3 Schuko IP67 2P+TTL 16A/250V 3 Schuko IP67 2P+E 16A/250V
30019	30 m H07RN-F 3 x 2,5 mm ²	Schuko IP67 2P+TTL 16A/250V IP67 schuko 2P+E 16/250V	3 Schuko IP67 2P+TTL 16A/250V 3 Schuko IP67 2P+E 16A/250V

Descripción: Enrollables con disyuntor
 • Grado de protección: **IP67**
 • Resistencia al impacto: **IK06**
 • Estabilidad dimensional: **-25°C +85°C**
 • Hilo incandescente: **750°C partes activas**
650°C otras partes
EN61242
 • Norma:

Description: Cable reel with safety cut out
 • Degree of protection: **IP67**
 • Impact resistance: **IK06**
 • Dimensional stability: **-25°C +85°C**
 • Glow wire test: **750°C active parts**
650°C other parts
EN61242
 • Norm:

Carga máxima / Max power		
	16A / 230V	1800 W
	16A / 400V	5500 W
	16A / 230V	3500 W
	16A / 400V	11000 W



* Incluye diferencial magnetotérmico 16A

* Include RCCB+MCB compaq circuit breaker 16A





7 INTERRUPTORES DE CORTE IP65

SAFETY SWITCHES IP65

La seguridad de las personas es esencial por eso en Famatel ponemos a su disposición nuestra nueva gama de interruptores de corte IP65. Fabricados con materiales altamente resistentes al impacto, la corrosión y agentes químicos, esta gama proporciona un punto extra de seguridad y garantía a la instalación.

The safety of people is essential, for that reason at Famatel we put at your disposal our new range of IP65 switches. Manufactured with materials highly resistant to impact, corrosion and chemical agents, this range provides an extra point of security and guarantee to the installation.



- Protección IP65
- Contactos de plata
- Entradas pretroueladas

- IP65 Protection
- Silver metal contacts
- Pre drilled entries

Interruptores / Switches

1

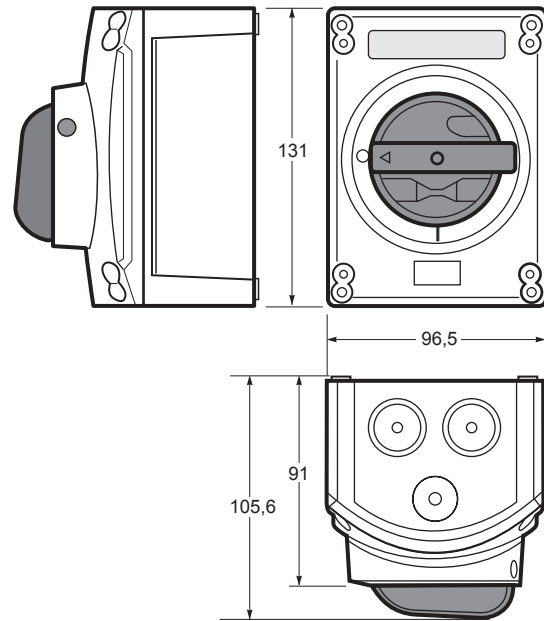

Rango de uso Range of use	Zona de utilización / Rating use Corriente nominal de utilización A / Nominal current of use A									
	Corriente nominal / Nominal current of use A									
	16		20		25		32		40	
AC23A	10A	690V	16A	690V	20A	690V	25A	690V	25A	690V
	16A	500V	20A	500V	25A	500V	32A	500V	32A	500V
AC22A	16A	690V	20A	690V	25A	690V	32A	690V	32A	690V
AC21A	16A	690V	20A	690V	25A	690V	32A	690V	40A	690V

Descripción / Description

Dimensiones (B*H*P) / External dimensions	B*H*P	96,5 x 131 x 105,50 mm
Peso / Weight	kg	0,150 kg
Grado de protección / Degree of protection	IP	IP65
Resistencia al impacto 20°C / Impact resistance	IK	IK 08
Temperatura de uso / Laying temperature	°C	-5 + 40
Temperatura máx. de utilización / Operating temperature	°C	60
Hilo incandescente / Resistance to glow wire test	°C	650
Norma de referencia / reference standards	CEI EN 60947-3	
Polos / Poles	P	2P - 3P - 4P
Tens. nominal aislamiento Ui / Rated insulation voltage	V	690
Tens. nominal a sobretensión / Rated voltage pulses	KV	6
Corriente nominal interior caja Rated thermal current inside the box	A	40
Corriente de cortocircuito condicional Rated conditional short-circuit	KA	10
Frecuencia / Frequency	Hz	50/60
Conexión flexible / conductores rígidos mm² Connecting conductors flexible / solid mm²	Min/Max	1,5 - 10

- Interruptor de corte diseñado para aplicaciones industriales y de consumo.
- Estructura dividida en 3 partes, fondo, cubierta (fabricado con materiales con alta resistencia mecánica a los golpes) y el interruptor interno.
- Disconnecting switch designed for industrial and domestic applications.
- Structure divided into 3 parts, bottom, cover (manufactured with high mechanical resistance materials) and the internal switch.



Corriente Nominal Nominal current	Nº Polos Poles	Notas Notes	Ref. / Item
16A	2+E		25510
	2+NP+E	Solid Neutral	25511
	3+E		25512
	3+NP+E	Solid Neutral	25513
	4+E		25514
20A	4+NP+E	Solid Neutral	25515
	2+E		25501
	2+NP+E	Solid Neutral	25516
	3+E		25502
	3+NP+E	Solid Neutral	25517
25A	4+E		25503
	4+NP+E	Solid Neutral	25518
	2+E	Solid Neutral	25519
	2+NP+E		25520
	3+E	Solid Neutral	25521
32A	3+NP+E		25522
	4+E	Solid Neutral	25523
	4+NP+E		25524
	2+E		25504
	2+NP+E	Solid Neutral	25525
40A	3+E		25505
	3+NP+E	Solid Neutral	25526
	4+E		25506
	4+NP+E	Solid Neutral	25527
	2+E	Solid Neutral	25507
40A	2+NP+E		25528
	3+E	Solid Neutral	25508
	3+NP+E		25529
	4+E	Solid Neutral	25509
	4+NP+E		25530





ARMARIOS Y MIRILLAS DE MANIOBRA
ENCLOSURES AND FUSE WINDOW



8.1



8.2



8.3



8.4



8.5



8.6



8.7



8.8



9

8.1 CAJAS INDUSTRIALES IP65
INDUSTRIAL ENCLOSURES IP65

- Gama modulable según sus necesidades de instalación
 - Sistema de sujeción de tomas de corriente universal (admite el 90% de las tomas del mercado)
 - Facilidad y rapidez de montaje
 - Diseñadas para su utilización en entornos industriales asegurando una alta resistencia a los agentes externos
- Modular range accordingly to your needs
 - Universal clamping system for flange sockets (accepts the 90% of the flange sockets of the market)
 - Easy and fast of assembly
 - Designed for its use in industrial environments, ensuring a high resistance to external agents

Nuevo concepto de cajas industriales modulares IP65, enlazables en sentido vertical y horizontal mediante racords de unión. La gama está compuesta por más de 12 modelos enlazables entre sí: cajas estancas, cajas universales para tomas industriales, cajas para los elementos de protección (diferenciales, magnetotérmicos, bobinas de emisión, etc).

A new concept of modular 65 industrial enclosures, linkable vertically and horizontally through a simple joining accessory. The range consists of over 12 models linkable together, sealed boxes for switchgears (circuit breakers, shunt, RCCB's, etc).



12 modelos combinables según necesidades
12 models to combine accordingly to your needs

Admite cualquier toma del mercado sin necesidad de troquelar
Ready to adapt any industrial socket available on the market without drilling the box

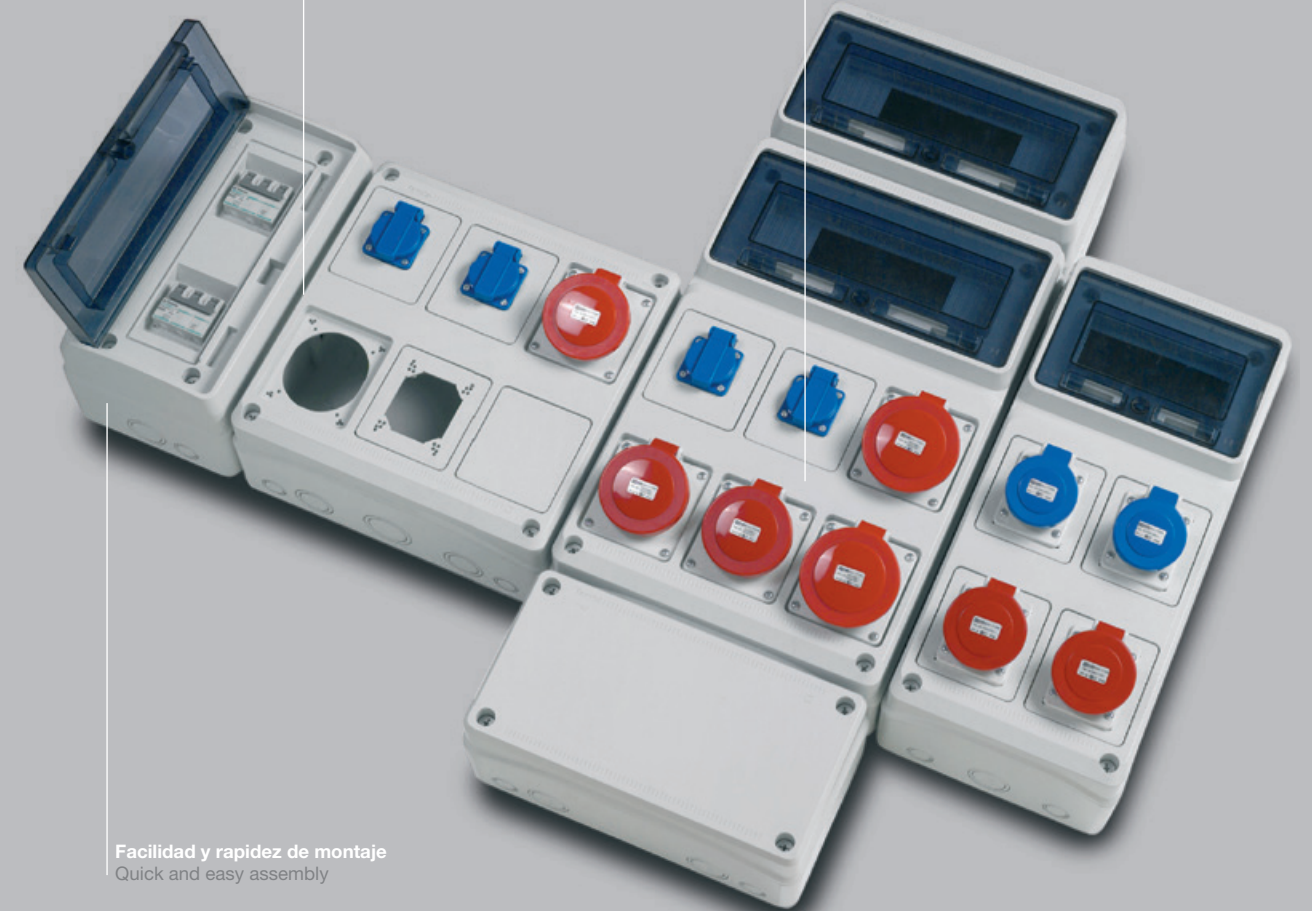

Facilidad y rapidez de montaje
Quick and easy assembly

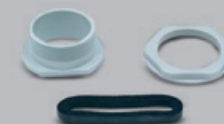

Racord de unión para cajas industriales AcquaCOMBI
Link for AcquaCOMBI boxes





Bisagras reversibles permitiendo apertura puerta 180°
Reversible hinges that allows a 180° door opening



Disposición de orificios en la base para sujeción de bornes, placas metálicas, etc...
Holes on the base for the fixation of metal bar, plates and other accessories



Disposición de entradas protoqueladas superiores
Pre-drilled entries on the top



Posibilidad de instalar cerradura metálica
Possibility of installing a metal lock



Carril DIN regulable en altura
DIN rail adjustable in height



Placa extraíble según necesidades de instalación
Removable plate for an easy cable and installation

Entradas protoqueladas
Knock-outs



Terminal de neutro y/o tierra
Earth/neutral bar



Cerradura metálica opcional
Optional metal lock



Sistema patentado de placa universal para tomas IP44 / IP67
Patented system of universal cover for IP44 / IP67 industrial sockets



Bisagras reversibles sujeción puerta
Reversible door hinges



Tapones tornillos
Screw covers



Fig.1
Pic.1

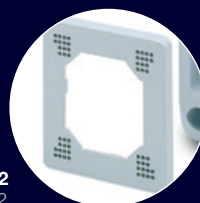

Fig.2
Pic.2

Según la toma a instalar del mercado, utilizar la placa extraíble troquelada (Fig.2) o el troquel directo de caja (Fig.1)
Depending on the socket to be installed, you may either use the plate provided (Pic.2) or fix the socket directly on to the enclosure (Pic.1)

CAJAS CIEGAS IP65

BLIND BOXES IP65

Pg. 132



CAJAS PRETROQUELADAS IP65

KNOCK-OUT BOXES IP65

Pg. 140



CAJAS TROQUELADAS PARA TOMAS INTERBLOCANTES

DRILLED BOXES FOR INTERLOCKED SOCKETS

Pg. 148



CAJAS COMPLEMENTARIAS MODULARES IP65

MODULAR COMPLEMENTARY BOXES IP65

Pg. 154



SOPORTES METÁLICOS AcquaCOMBI

METAL SUPPORTS AcquaCOMBI

Pg. 158



ACCESORIOS

ACCESSORIES

Pg. 160

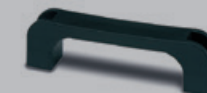

CAJAS CIEGAS IP65 / BLIND BOXES IP65

Caja ciega / Blind box - Ref. Item 3927

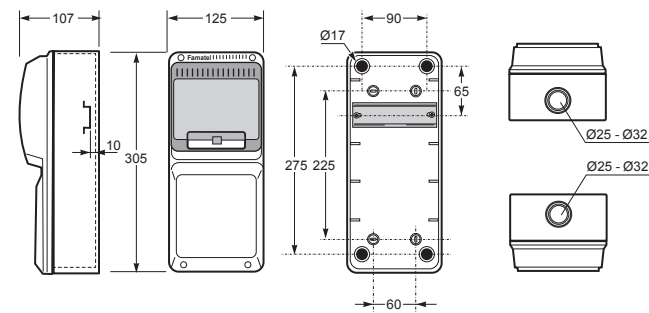

Dimensiones / Dimensions	
Altura / Height	305
Ancho / Width	125
Profundidad / Deep	107

Entradas / Entries	
Superior / Top	1 x Ø25 / 32
Inferior / Bottom	1 x Ø25 / 32

No enlazable / No linkable
Norma / Norm: EN62208



- Marco y base en ABS
- Ventana transparente en PC
- Incluye tapones interiores para IP

- Frame and base in ABS
- Windows transparent in PC
- Screw taps included for IP



Ref. Item 3927

Caja ciega / Blind box - Ref. Item 3950

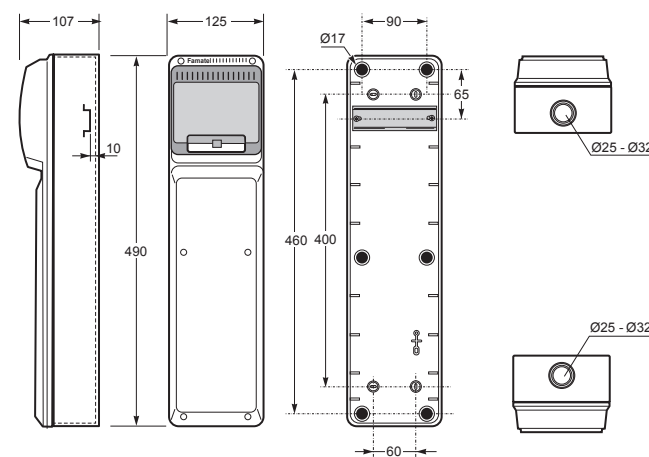

Dimensiones / Dimensions	
Altura / Height	490
Ancho / Width	125
Profundidad / Deep	107

Entradas / Entries	
Superior / Top	1 x Ø25 / 32
Inferior / Bottom	1 x Ø25 / 32

No enlazable / No linkable
Norma / Norm: EN62208



- Marco y base en ABS
- Ventana transparente en PC
- Incluye tapones interiores para IP

- Frame and base in ABS
- Windows transparent in PC
- Screw taps included for IP



Ref. Item 3950

Caja ciega / Blind box - Ref. Item 3951

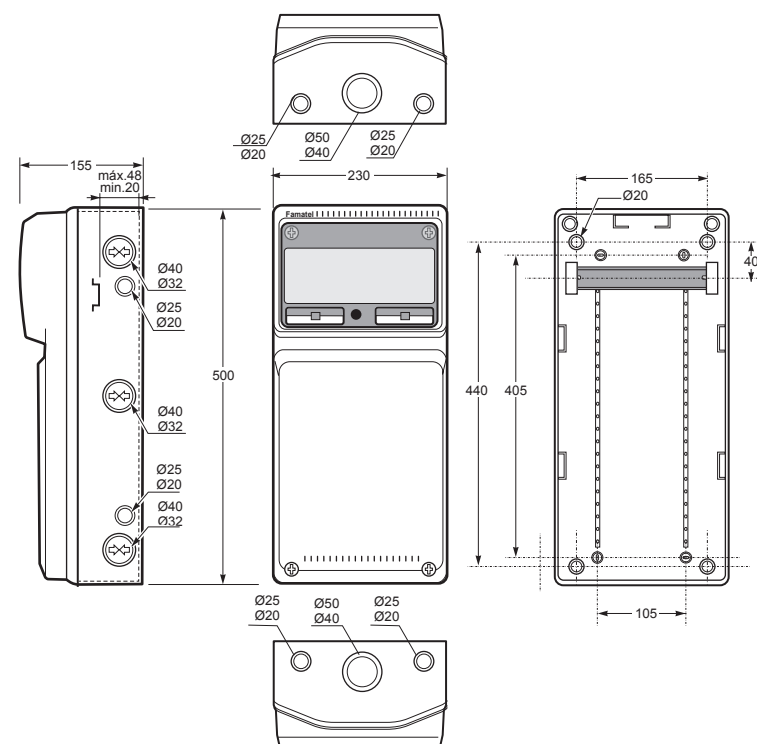

Dimensiones / Dimensions	
Altura / Height	500
Ancho / Width	230
Profundidad / Deep	155

Entradas / Entries	
Superior / Top	2 x Ø25 - Ø20 + 1 x Ø50 - Ø40
Inferior / Bottom	2 x Ø25 - Ø20 + 1 x Ø50 - Ø40
Lado / Side	3 x Ø40 - Ø32 + 2 x Ø25 - Ø20

Enlazable / Linkable
Norma / Norm: EN62208



- Marco y base en ABS
- Ventana transparente en PC
- Incluye tapones interiores para IP

- Frame and base in ABS
- Windows transparent in PC
- Screw taps included for IP



Ref. Item 3951

CAJAS CIEGAS IP65 / BLIND BOXES IP65

Caja ciega / Blind box - Ref. Item **3974**

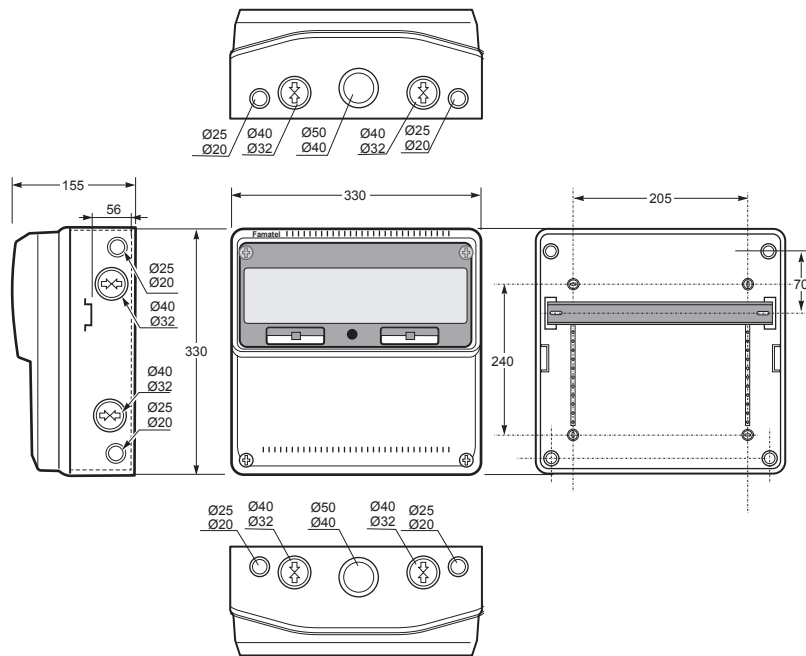

Dimensiones / Dimensions	
Altura / Height	330
Ancho / Width	330
Profundidad / Deep	155

Entradas / Entries	
Superior / Top	2 x Ø40-Ø32 + 2 x Ø25-Ø20 + 1 x Ø50-Ø40
Inferior / Bottom	2 x Ø40-Ø32 + 2 x Ø25-Ø20 + 1 x Ø50-Ø40
Lado / Side	2 x Ø40-Ø32 + 2 x Ø25-Ø20

Enlazable / Linkable
Norma / Norm: **EN62208**

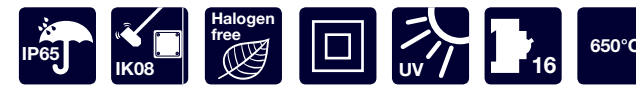

- Marco y base en ABS
- Ventana transparente en PC
- Incluye tapones interiores para IP

- Frame and base in ABS
- Windows transparent in PC
- Screw taps included for IP



Ref. Item **3974**

Caja ciega / Blind box - Ref. Item **3952**

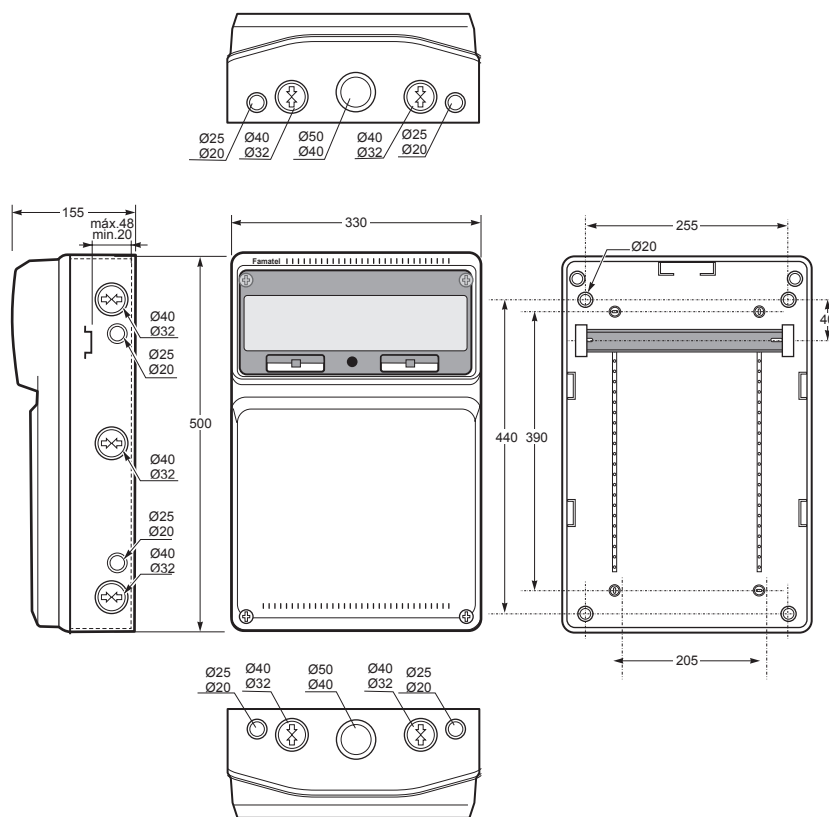

Dimensiones / Dimensions	
Altura / Height	500
Ancho / Width	330
Profundidad / Deep	155

Entradas / Entries	
Superior / Top	2 x Ø40-Ø32 + 2 x Ø25-Ø20 + 1 x Ø50-Ø40
Inferior / Bottom	2 x Ø40-Ø32 + 2 x Ø25-Ø20 + 1 x Ø50-Ø40
Lado / Side	3 x Ø40 - Ø32 + 2 x Ø25 - Ø20

Enlazable / Linkable
Norma / Norm: **EN62208**



- Marco y base en ABS
- Ventana transparente en PC
- Incluye tapones interiores para IP

- Frame and base in ABS
- Windows transparent in PC
- Screw taps included for IP



Ref. Item **3952**

Caja ciega / Blind box - Ref. Item **3977**

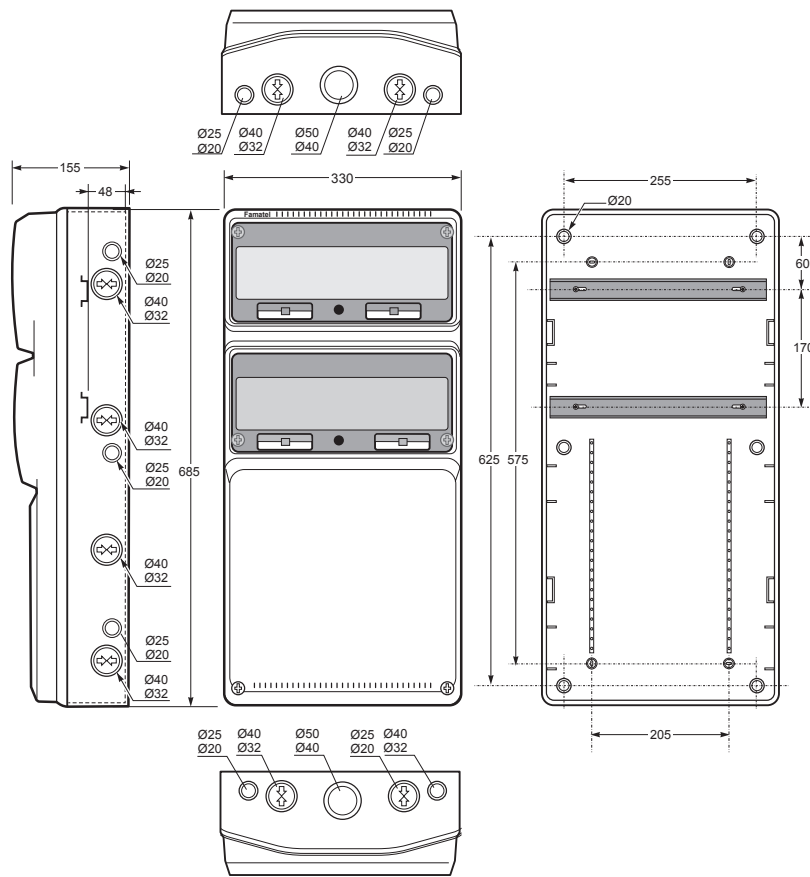

Dimensiones / Dimensions	
Altura / Height	685
Ancho / Width	330
Profundidad / Deep	155

Entradas / Entries	
Superior / Top	2 x Ø25-Ø20 + 2 x Ø40-Ø32 + 1 x Ø50-Ø40
Inferior / Bottom	2 x Ø25-Ø20 + 2 x Ø40-Ø32 + 1 x Ø50-Ø40
Lado / Side	3 x Ø25 - Ø20 + 4 x Ø40 - Ø32

Enlazable / Linkable
Norma / Norm: **EN62208**



- Marco y base en ABS
- Ventana transparente en PC
- Incluye tapones interiores para IP
- Frame and base in ABS
- Windows transparent in PC
- Screw taps included for IP



Ref. Item **3977**

CAJAS CIEGAS IP65 / BLIND BOXES IP65

Caja ciega / Blind box - Ref. Item **3957**

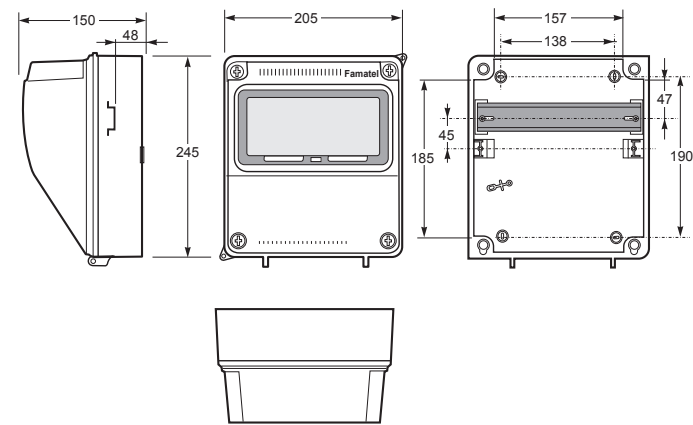

Dimensiones / Dimensions	
Altura / Height	245
Ancho / Width	205
Profundidad / Deep	150

No enlazable / No linkable
Norma / Norm: EN62208



- Marco y base en ABS
- Ventana transparente en PC
- Incluye tapones interiores para IP

- Frame and base in ABS
- Windows transparent in PC
- Screw taps included for IP



Ref. Item **3957**

Caja ciega / Blind box - Ref. Item **3958**

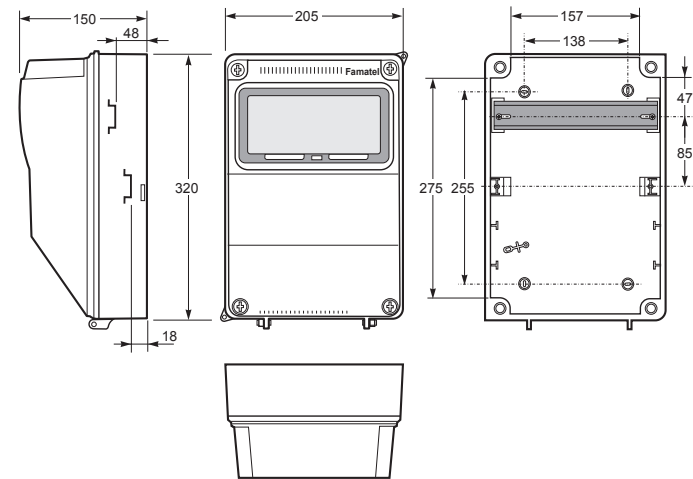

Dimensiones / Dimensions	
Altura / Height	320
Ancho / Width	205
Profundidad / Deep	150

No enlazable / No linkable
Norma / Norm: EN62208

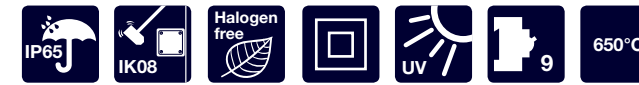

- Marco y base en ABS
- Ventana transparente en PC
- Incluye tapones interiores para IP

- Frame and base in ABS
- Windows transparent in PC
- Screw taps included for IP



Ref. Item **3958**

Caja ciega / Blind box - Ref. Item **3959**

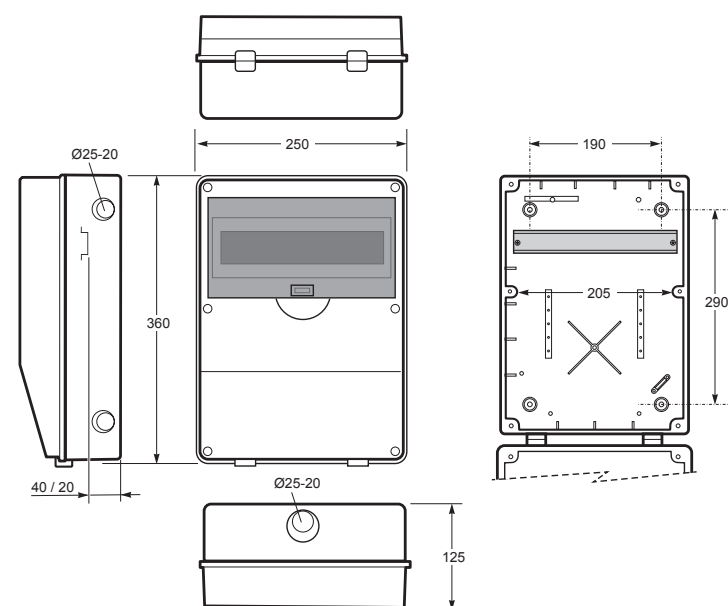

Dimensiones / Dimensions	
Altura / Height	360
Ancho / Width	250
Profundidad / Deep	125

No enlazable / No linkable
Norma / Norm: EN62208



- Marco y base en ABS
- Ventana transparente en PC
- Incluye tapones interiores para IP

- Frame and base in ABS
- Windows transparent in PC
- Screw taps included for IP



Ref. Item **3959**

CAJAS PRETROQUELADAS IP65 / KNOCK-OUT BOXES IP65

Caja pretroquelada / Knock-out box - Ref. Item **3928**

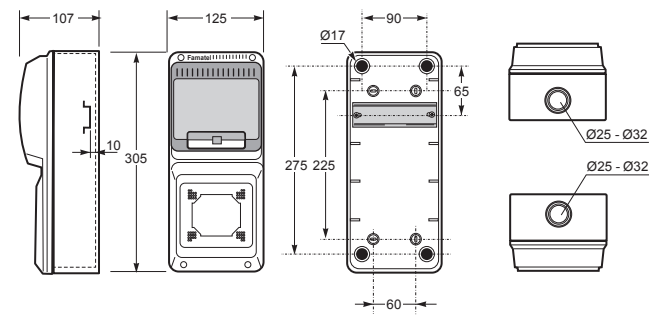

Dimensiones / Dimensions	
Altura / Height	305
Ancho / Width	125
Profundidad / Deep	107

Entradas / Entries	
Superior / Top	1 x Ø25 / 32
Inferior / Bottom	1 x Ø25 / 32

No enlazable / No linkable
Norma / Norm: EN62208



1 IEC 16A/32A IP44/IP67
*Consultar por 63A
Ask for 63A

- Marco y base en ABS
- Ventana transparente en PC
- Incluye tapones interiores para IP

- Frame and base in ABS
- Windows transparent in PC
- Screw taps included for IP



Ref. Item **3928**

Caja pretroquelada / Knock-out box - Ref. Item **3960**

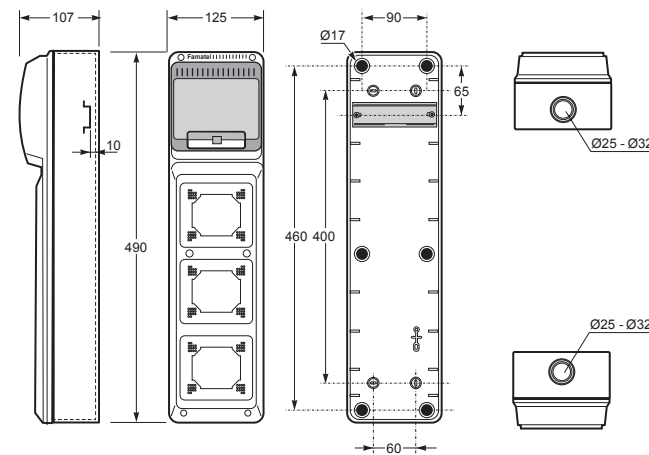

Dimensiones / Dimensions	
Altura / Height	490
Ancho / Width	125
Profundidad / Deep	107

Entradas / Entries	
Superior / Top	1 x Ø25 / 32
Inferior / Bottom	1 x Ø25 / 32

No enlazable / No linkable
Norma / Norm: EN62208



3 IEC 16A/32A IP44/IP67
*Consultar por 63A
Ask for 63A

- Marco y base en ABS
- Ventana transparente en PC
- Incluye tapones interiores para IP

- Frame and base in ABS
- Windows transparent in PC
- Screw taps included for IP



Ref. Item **3960**

Caja pretroquelada / Knock-out box - Ref. Item **3975**

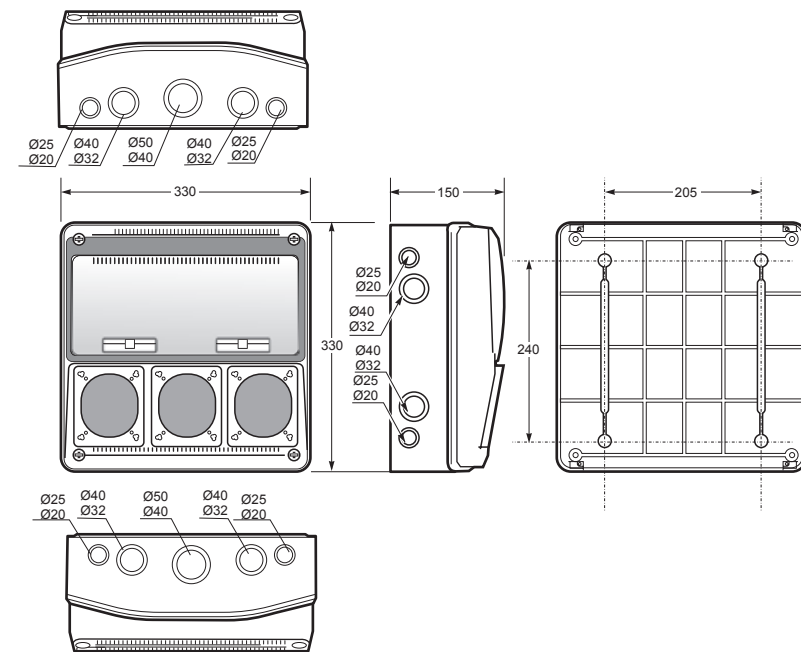

Dimensiones / Dimensions	
Altura / Height	330
Ancho / Width	330
Profundidad / Deep	150

Entradas / Entries	
Superior / Top	2 x Ø40-Ø32 + 2 x Ø25-Ø20 + 1 x Ø50-Ø40
Inferior / Bottom	2 x Ø40-Ø32 + 2 x Ø25-Ø20 + 1 x Ø50-Ø40
Lado / Side	2 x Ø40-Ø32 + 2 x Ø25-Ø20

Enlazable / Linkable
Norma / Norm: EN62208



3 IEC 16A/32A IP44/IP67
*Consultar por 63A
Ask for 63A

- Marco y base en ABS
- Ventana transparente en PC
- Incluye tapones interiores para IP

- Frame and base in ABS
- Windows transparent in PC
- Screw taps included for IP



Ref. Item **3975**

CAJAS PRETROQUELADAS IP65 / KNOCK-OUT BOXES IP65

Caja pretroquelada / Knock-out box - Ref. Item **3961**

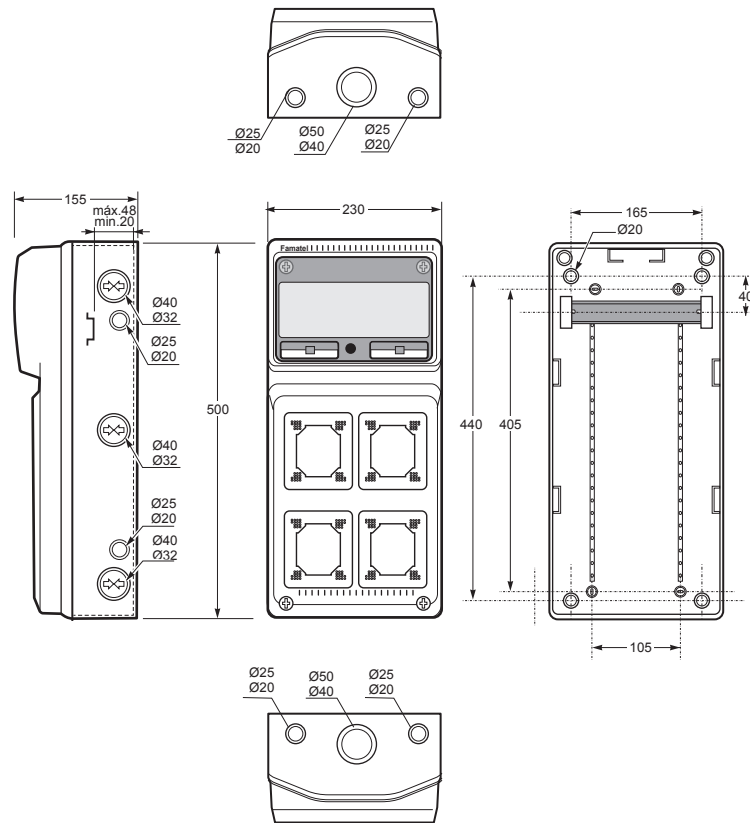

Dimensiones / Dimensions	
Altura / Height	500
Ancho / Width	230
Profundidad / Deep	155

Entradas / Entries	
Superior / Top	2 x Ø25 - Ø20 + 1 x Ø50 - Ø40
Inferior / Bottom	2 x Ø25 - Ø20 + 1 x Ø50 - Ø40
Lado / Side	3 x Ø40 - Ø32 + 2 x Ø25 - Ø20

Enlazable / Linkable
Norma / Norm: **EN62208**



4 IEC 16A/32A IP44/IP67
*Consultar por 63A
Ask for 63A

- Marco y base en ABS
- Ventana transparente en PC
- Incluye tapones interiores para IP

- Frame and base in ABS
- Windows transparent in PC
- Screw taps included for IP



Ref. Item **3961**

Caja pretroquelada / Knock-out box - Ref. Item **3962**

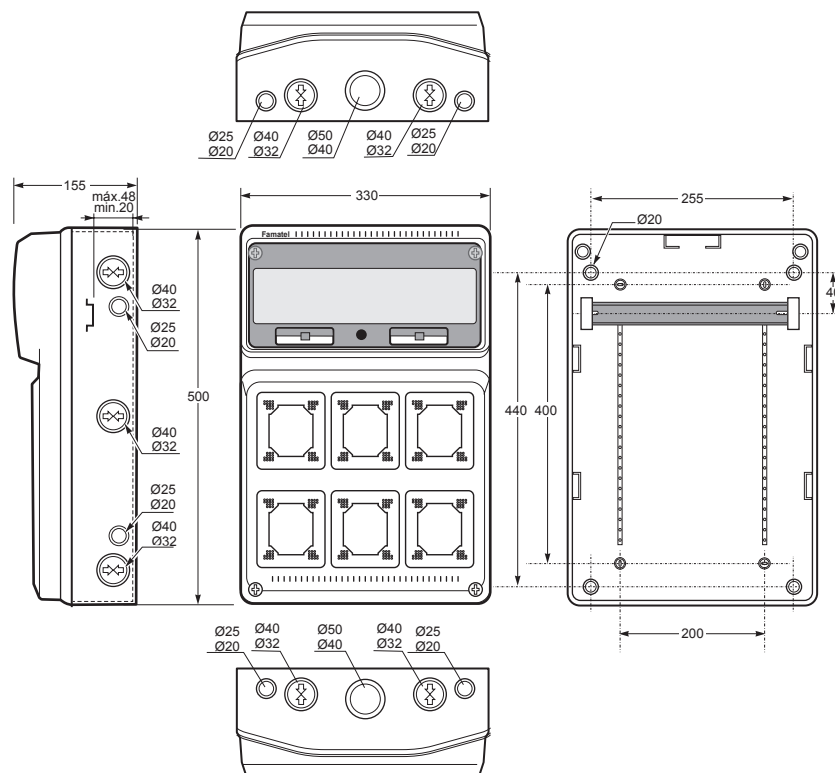

Dimensiones / Dimensions	
Altura / Height	500
Ancho / Width	330
Profundidad / Deep	155

Entradas / Entries	
Superior / Top	2 x Ø40-Ø32 + 2 x Ø25-Ø20 + 1 x Ø50-Ø40
Inferior / Bottom	2 x Ø40-Ø32 + 2 x Ø25-Ø20 + 1 x Ø50-Ø40
Lado / Side	3 x Ø40 - Ø32 + 2 x Ø25 - Ø20

Enlazable / Linkable
Norma / Norm: **EN62208**



6 IEC 16A/32A IP44/IP67
*Consultar por 63A
Ask for 63A

- Marco y base en ABS
- Ventana transparente en PC
- Incluye tapones interiores para IP

- Frame and base in ABS
- Windows transparent in PC
- Screw taps included for IP



Ref. Item **3962**

Caja pretroquelada / Knock-out box - Ref. Item **3978**

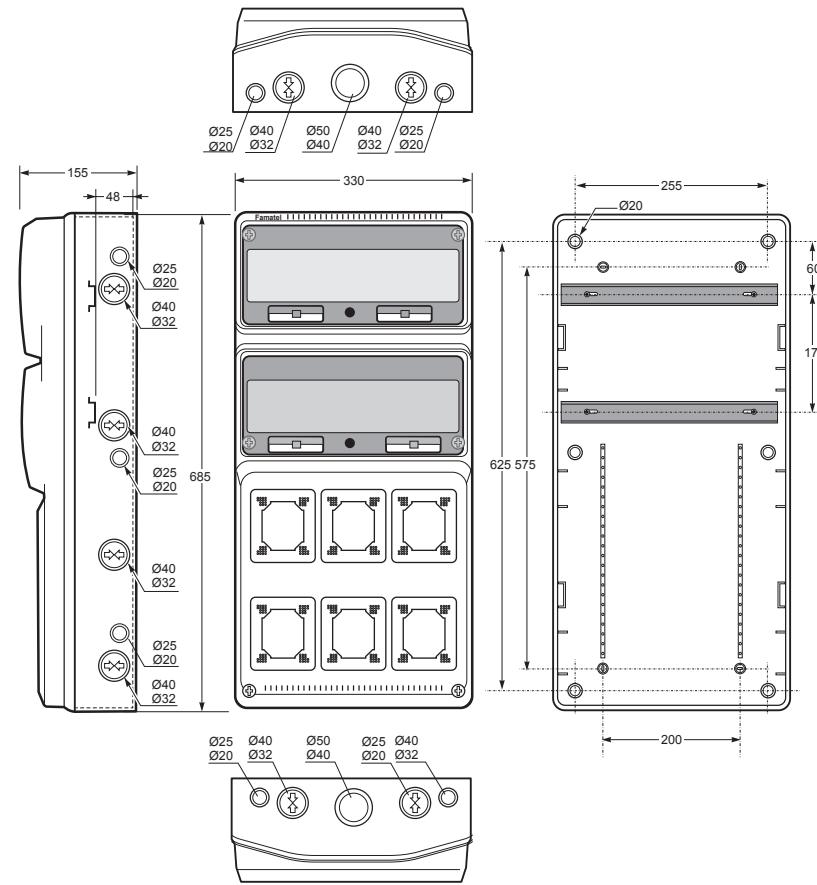

Dimensiones / Dimensions	
Altura / Height	685
Ancho / Width	330
Profundidad / Deep	155

Entradas / Entries	
Superior / Top	2 x Ø25-Ø20 + 2 x Ø40-Ø32 + 1 x Ø50-Ø40
Inferior / Bottom	2 x Ø25-Ø20 + 2 x Ø40-Ø32 + 1 x Ø50-Ø40
Lado / Side	3 x Ø25 - Ø20 + 4 x Ø40 - Ø32

Enlazable / Linkable
Norma / Norm: **EN62208**



6 IEC 16A/32A IP44/IP67
*Consultar por 63A
Ask for 63A

- Marco y base en ABS
- Ventana transparente en PC
- Incluye tapones interiores para IP

- Frame and base in ABS
- Windows transparent in PC
- Screw taps included for IP



Ref. Item **3978**

CAJAS PRETROQUELADAS IP65 / KNOCK-OUT BOXES IP65

Caja pretroquelada / Knock-out box - Ref. Item **3963**

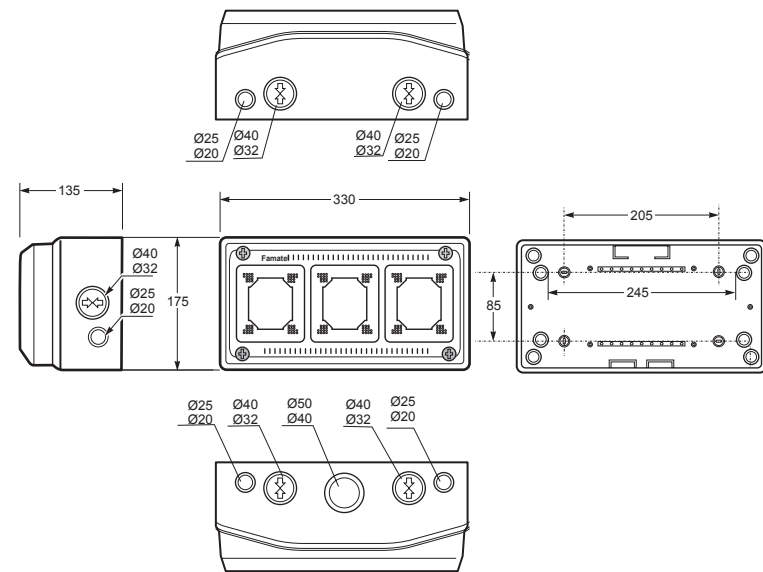

Dimensiones / Dimensions	
Altura / Height	175
Ancho / Width	330
Profundidad / Deep	135

Entradas / Entries	
Superior / Top	2 x Ø40-Ø32 + 2 x Ø25-Ø20 + 1 x Ø50-Ø40
Inferior / Bottom	2 x Ø40-Ø32 + 2 x Ø25-Ø20
Lado / Side	1 x Ø40-Ø32 + 1 x Ø25-Ø20

Enlazable / Linkable
Norma / Norm: **EN62208**



3 IEC 16A/32A IP44/IP67
*Consultar por 63A
Ask for 63A

- Marco y base en ABS
- Ventana transparente en PC
- Incluye tapones interiores para IP

- Frame and base in ABS
- Windows transparent in PC
- Screw taps included for IP



ef. Item **3963**

Caja pretroquelada / Knock-out box - Ref. Item **3966**

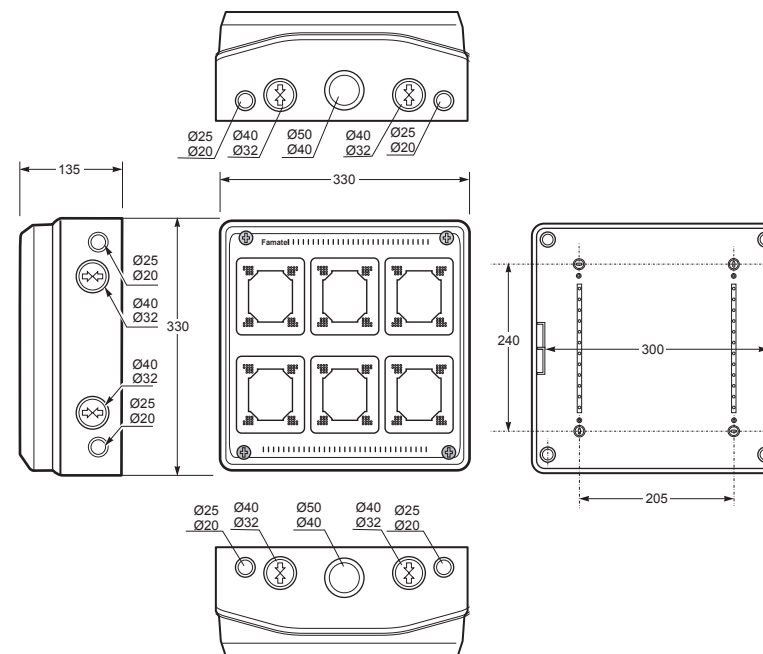

Dimensiones / Dimensions	
Altura / Height	330
Ancho / Width	330
Profundidad / Deep	135

Entradas / Entries	
Superior / Top	2 x Ø25 - Ø20 + 1 x Ø40 - Ø32 + 1 x Ø50 - Ø40
Inferior / Bottom	2 x Ø25 - Ø20 + 1 x Ø40 - Ø32 + 1 x Ø50 - Ø40
Lado / Side	2 x Ø40 - Ø32 + 2 x Ø25 - Ø20

Enlazable / Linkable
Norma / Norm: **EN62208**



3 IEC 16A/32A IP44/IP67
*Consultar por 63A
Ask for 63A

- Marco y base en ABS
- Ventana transparente en PC
- Incluye tapones interiores para IP

- Frame and base in ABS
- Windows transparent in PC
- Screw taps included for IP



Ref. Item **3966**

CAJAS TROQUELADAS PARA TOMAS INTERBLOCANTES / DRILLED BOXES FOR INTERLOCKED SOCKETS

Caja Troquelada / Drilled box - Ref. Item **3967**

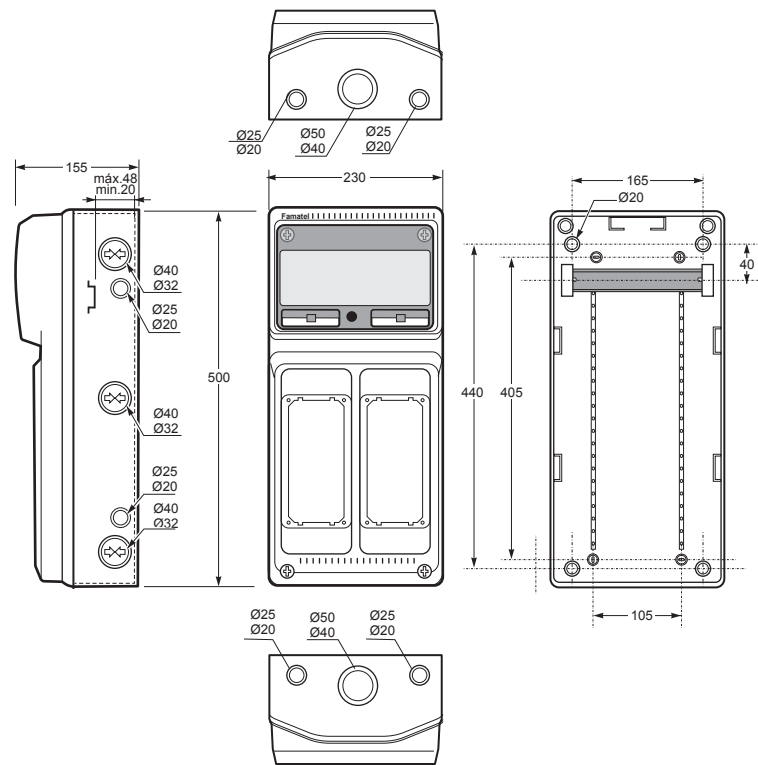

Dimensiones / Dimensions	
Altura / Height	500
Ancho / Width	230
Profundidad / Deep	155

Entradas / Entries	
Superior / Top	2 x Ø25-Ø20 + 1 x Ø50-Ø40
Inferior / Bottom	2 x Ø25-Ø20 + 1 x Ø50-Ø40
Lado / Side	3 x Ø40-Ø32 + 2 x Ø25-Ø20

Enlazable / Linkable
Norma / Norm: **EN62208**



- Marco y base en ABS
- Ventana transparente en PC
- Incluye tapones interiores para IP

- Frame and base in ABS
- Windows transparent in PC
- Screw taps included for IP



Ref. Item **3967**

Caja Troquelada / Drilled box - Ref. Item **3968**

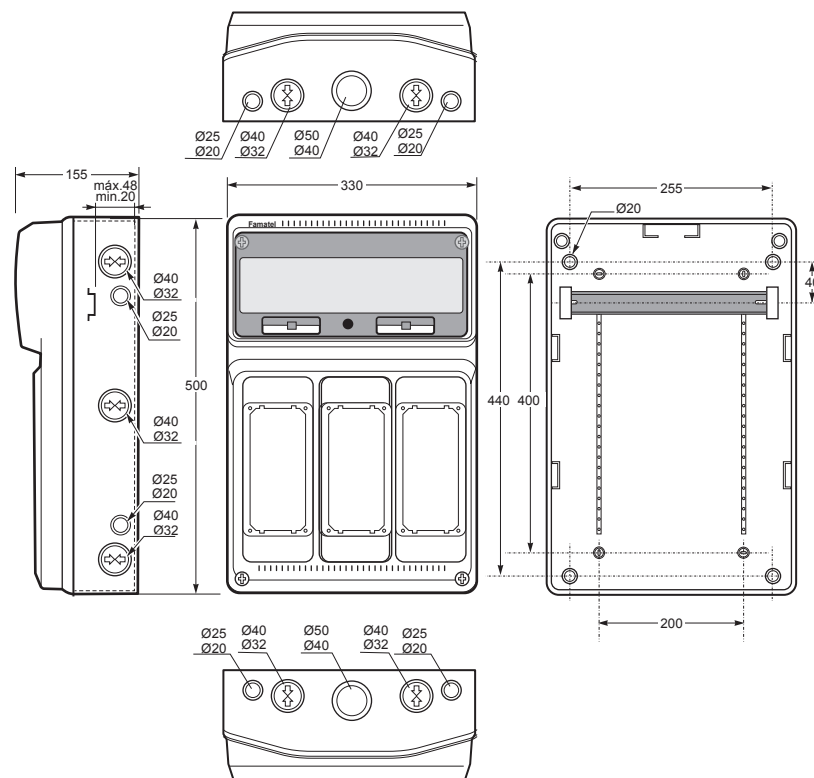

Dimensiones / Dimensions	
Altura / Height	500
Ancho / Width	330
Profundidad / Deep	155

Entradas / Entries	
Superior / Top	2 x Ø40-Ø32 + 2 x Ø25-Ø20 + 1 x Ø50-Ø40
Inferior / Bottom	2 x Ø40-Ø32 + 2 x Ø25-Ø20 + 1 x Ø50-Ø40
Lado / Side	3 x Ø40-Ø32 + 2 x Ø25-Ø20

Enlazable / Linkable
Norma / Norm: **EN62208**



- Marco y base en ABS
- Ventana transparente en PC
- Incluye tapones interiores para IP

- Frame and base in ABS
- Windows transparent in PC
- Screw taps included for IP



Ref. Item **3968**

CAJAS TROQUELADAS PARA TOMAS INTERBLOCANTES / DRILLED BOXES FOR INTERLOCKED SOCKETS

Caja Troquelada / Drilled box - Ref. Item **3969**

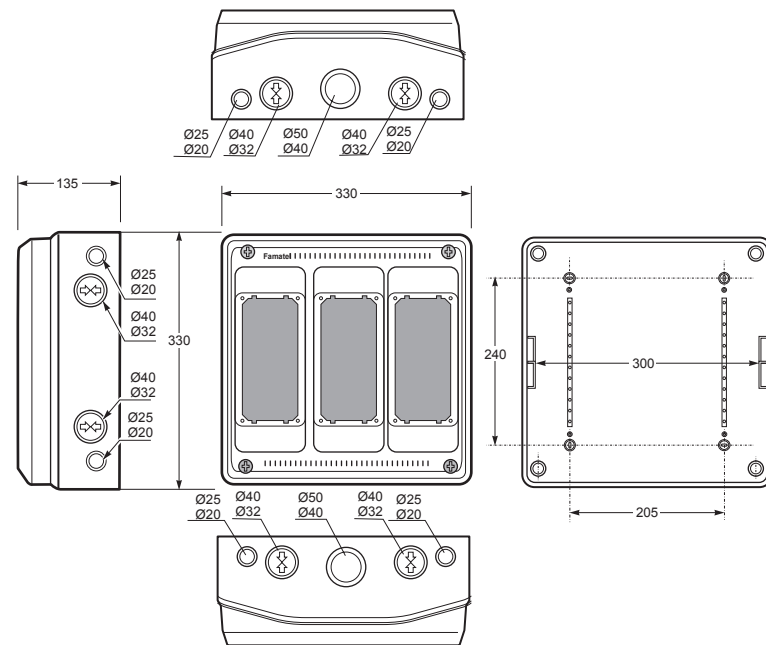

Dimensiones / Dimensions	
Altura / Height	330
Ancho / Width	330
Profundidad / Deep	135

Entradas / Entries	
Superior / Top	2 x Ø40-Ø32 + 2 x Ø25-Ø20 + 1 x Ø50-Ø40
Inferior / Bottom	2 x Ø40-Ø32 + 2 x Ø25-Ø20 + 1 x Ø50-Ø40
Lado / Side	2 x Ø40-Ø32 + 2 x Ø25-Ø20

Enlazable / Linkable
Norma / Norm: EN62208

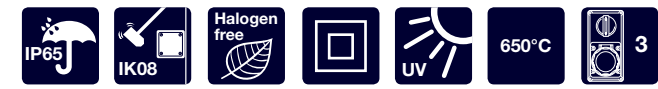

3 IEC Interlocked
Vertical IP44/IP67

- Marco y base en ABS
- Ventana transparente en PC
- Incluye tapones interiores para IP

- Frame and base in ABS
- Windows transparent in PC
- Screw taps included for IP



Ref. Item
3969

Caja Troquelada / Drilled box - Ref. Item **3970**

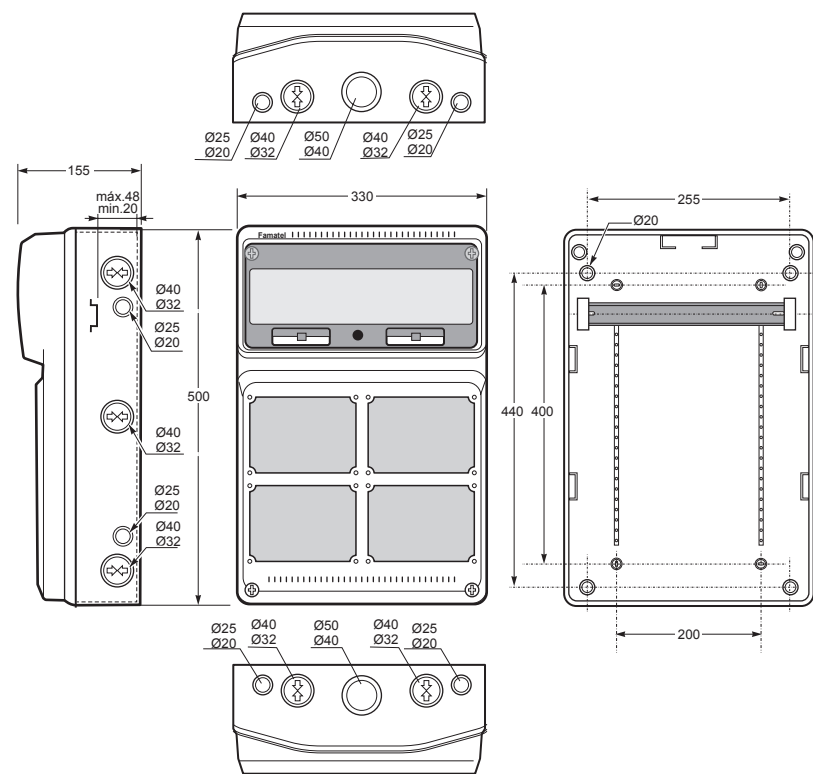

Dimensiones / Dimensions	
Altura / Height	500
Ancho / Width	330
Profundidad / Deep	155

Entradas / Entries	
Superior / Top	2 x Ø40-Ø32 + 2 x Ø25-Ø20 + 1 x Ø50-Ø40
Inferior / Bottom	2 x Ø40-Ø32 + 2 x Ø25-Ø20 + 1 x Ø50-Ø40
Lado / Side	3 x Ø40 - Ø32 + 2 x Ø25 - Ø20

Enlazable / Linkable
Norma / Norm: EN62208



4 IEC Interlocked
Horizontal IP44/IP67

- Marco y base en ABS
- Ventana transparente en PC
- Incluye tapones interiores para IP

- Frame and base in ABS
- Windows transparent in PC
- Screw taps included for IP



Ref. Item
3970

CAJAS TROQUELADAS PARA TOMAS INTERBLOCANTES / DRILLED BOXES FOR INTERLOCKED SOCKETS

Caja Troquelada / Drilled box - Ref. Item **3979**

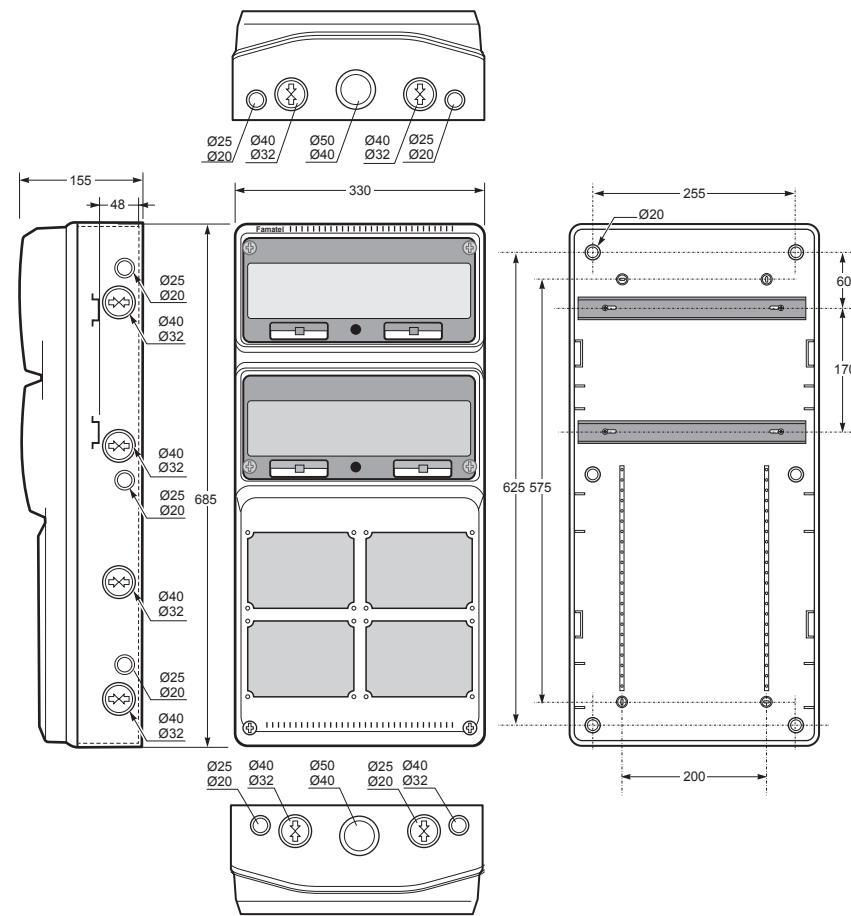

Dimensiones / Dimensions	
Altura / Height	685
Ancho / Width	330
Profundidad / Deep	155

Entradas / Entries	
Superior / Top	2 x Ø40-Ø32 + 2 x Ø25-Ø20 + 1 x Ø50-Ø40
Inferior / Bottom	2 x Ø40-Ø32 + 2 x Ø25-Ø20 + 1 x Ø50-Ø40
Lado / Side	3 x Ø25-Ø20 + 4 x Ø40-Ø32

Enlazable / Linkable
Norma / Norm: **EN62208**



- Marco y base en ABS
- Ventana transparente en PC
- Incluye tapones interiores para IP

- Frame and base in ABS
- Windows transparent in PC
- Screw taps included for IP



Ref. Item **3979**

Caja Troquelada / Drilled box - Ref. Item **3973**

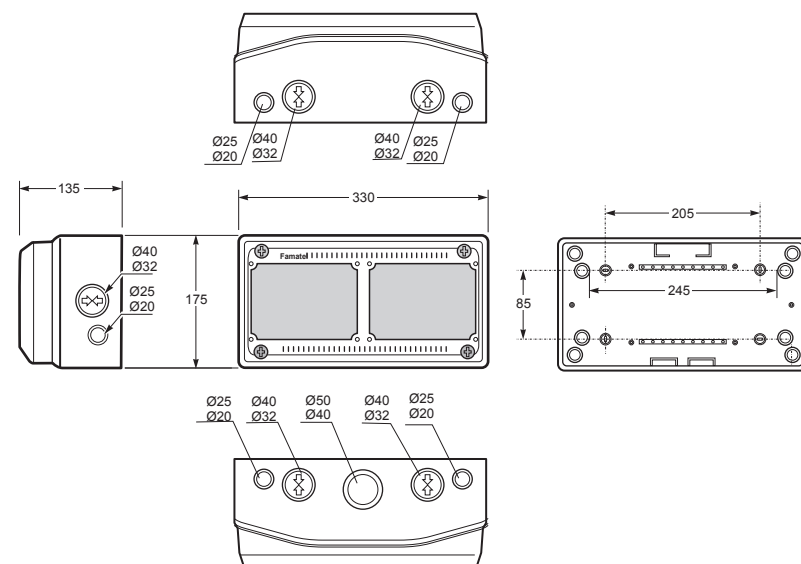

Dimensiones / Dimensions	
Altura / Height	175
Ancho / Width	330
Profundidad / Deep	135

Entradas / Entries	
Superior / Top	2 x Ø40-Ø32 + 2 x Ø25-Ø20 + 1 x Ø50-Ø40
Inferior / Bottom	2 x Ø40-Ø32 + 2 x Ø25-Ø20
Lado / Side	1 x Ø40-Ø32 + 1 x Ø25-Ø20

Enlazable / Linkable
Norma / Norm: **EN62208**



- Marco y base en ABS
- Ventana transparente en PC
- Incluye tapones interiores para IP

- Frame and base in ABS
- Windows transparent in PC
- Screw taps included for IP



Ref. Item **3973**

CAJAS COMPLEMENTARIAS MODULARES IP65 / MODULAR COMPLEMENTARY BOXES IP65

Caja Troquelada / Drilled box - Ref. Item **3964**

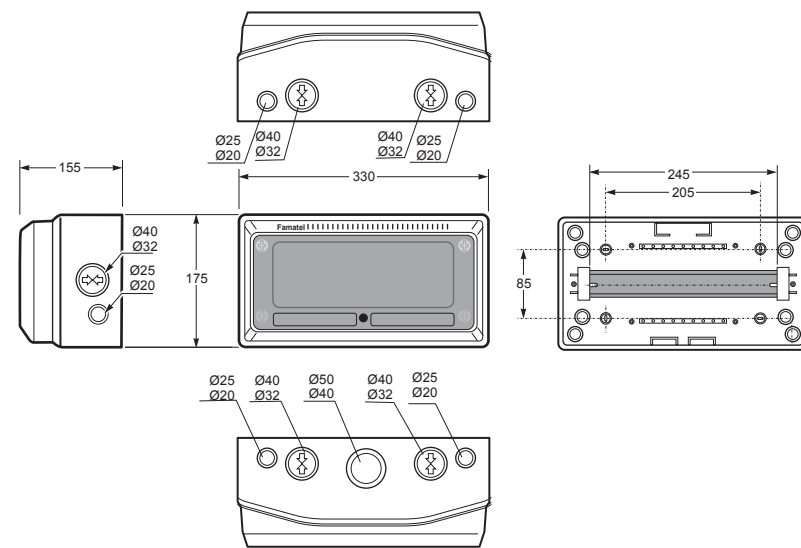

Dimensiones / Dimensions	
Altura / Height	175
Ancho / Width	330
Profundidad / Deep	155

Entradas / Entries	
Superior / Top	2 x Ø40-Ø32 + 2 x Ø25-Ø20 + 1 x Ø50-Ø40
Inferior / Bottom	2 x Ø40-Ø32 + 2 x Ø25-Ø20
Lado / Side	1 x Ø40-Ø32 + 1 x Ø25-Ø20

Enlazable / Linkable
Norma / Norm: **EN62208**

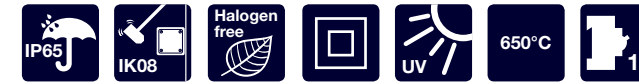

- Marco y base en ABS
- Ventana transparente en PC
- Incluye tapones interiores para IP

- Frame and base in ABS
- Windows transparent in PC
- Screw taps included for IP



Ref. Item **3964**

Caja Troquelada / Drilled box - Ref. Item **3955**

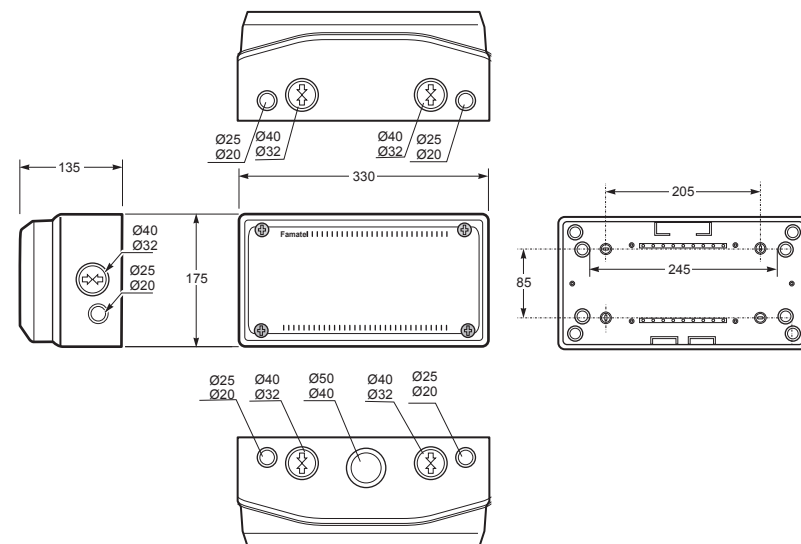

Dimensiones / Dimensions	
Altura / Height	175
Ancho / Width	330
Profundidad / Deep	135

Entradas / Entries	
Superior / Top	2 x Ø40-Ø32 + 2 x Ø25-Ø20 + 1 x Ø50-Ø40
Inferior / Bottom	2 x Ø40-Ø32 + 2 x Ø25-Ø20
Lado / Side	1 x Ø40-Ø32 + 1 x Ø25-Ø20

Enlazable / Linkable
Norma / Norm: **EN62208**



- Marco y base en ABS
- Ventana transparente en PC
- Incluye tapones interiores para IP

- Frame and base in ABS
- Windows transparent in PC
- Screw taps included for IP

Es posible la instalación placa metálica
It is possible installing a metal plate (Ref. Item **PL-3955**)



Ref. Item **3955**

Caja Troquelada / Drilled box - Ref. Item **3956**

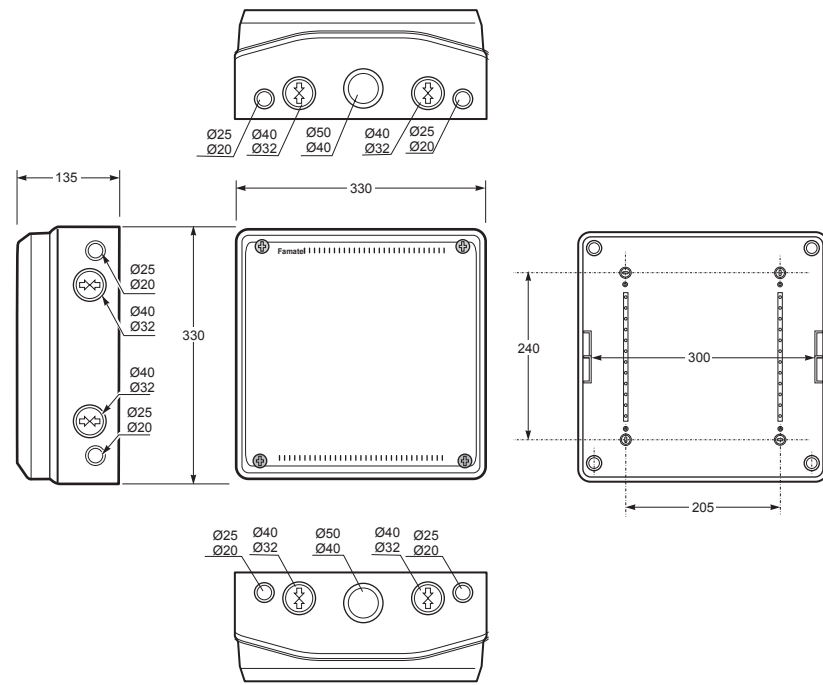

Dimensiones / Dimensions	
Altura / Height	320
Ancho / Width	330
Profundidad / Deep	135

Entradas / Entries	
Superior / Top	2 x Ø40-Ø32 + 2 x Ø25-Ø20 + 1 x Ø50-Ø40
Inferior / Bottom	2 x Ø40-Ø32 + 2 x Ø25-Ø20 + 1 x Ø50-Ø40
Lado / Side	2 x Ø40-Ø32 + 2 x Ø25-Ø20

Enlazable / Linkable
Norma / Norm: EN62208



- Marco y base en ABS
- Ventana transparente en PC
- Incluye tapones interiores para IP

- Frame and base in ABS
- Windows transparent in PC
- Screw taps included for IP

Es posible la instalació placa metálica
It is posible installing a metal plate (Ref. Item **PL-3956**)



Ref. Item **3956**

Caja Troquelada / Drilled box - Ref. Item **3953**

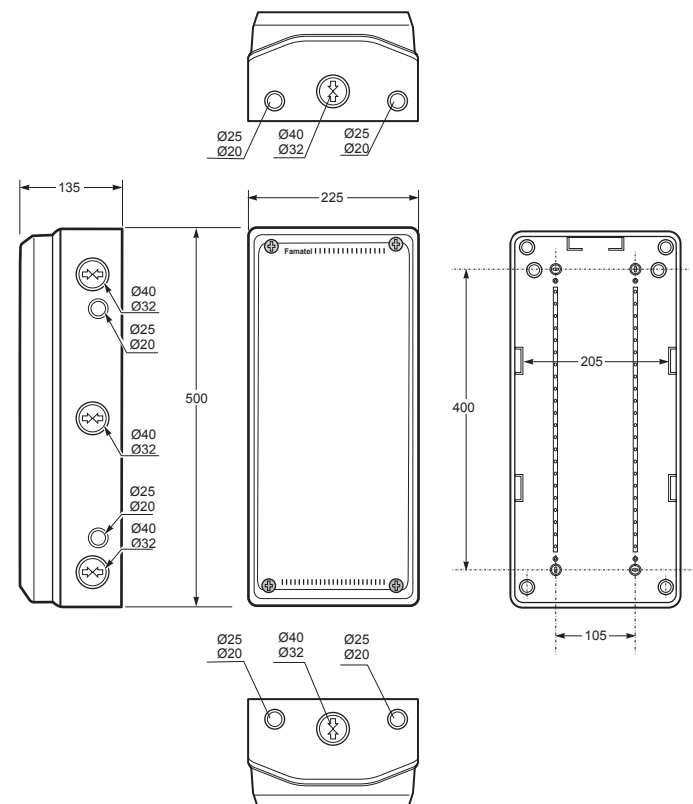

Dimensiones / Dimensions	
Altura / Height	500
Ancho / Width	225
Profundidad / Deep	135

Entradas / Entries	
Superior / Top	2 x Ø25-Ø20 + 1 x Ø40-Ø32
Inferior / Bottom	2 x Ø25-Ø20 + 1 x Ø40-Ø32
Lado / Side	3 x Ø40 - Ø32 + 2 x Ø25 - Ø20

Enlazable / Linkable
Norma / Norm: EN62208



- Marco y base en ABS
- Ventana transparente en PC
- Incluye tapones interiores para IP

- Frame and base in ABS
- Windows transparent in PC
- Screw taps included for IP

Es posible la instalació placa metálica
It is posible installing a metal plate (Ref. Item **PL-3953**)



Ref. Item **3953**

CAJAS COMPLEMENTARIAS MODULARES IP65 / MODULAR COMPLEMENTARY BOXES IP65

Caja Troquelada / Drilled box - Ref. Item **3954**

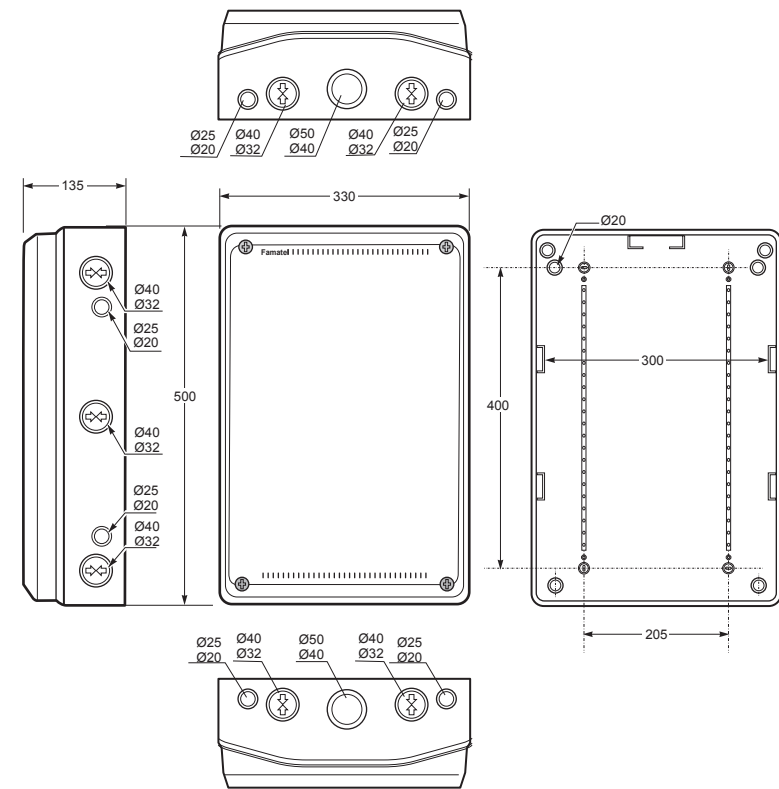

Dimensiones / Dimensions	
Altura / Height	500
Ancho / Width	330
Profundidad / Deep	135

Entradas / Entries	
Superior / Top	2 x Ø40-Ø32 + 2 x Ø25-Ø20 + 1 x Ø50-Ø40
Inferior / Bottom	2 x Ø40-Ø32 + 2 x Ø25-Ø20 + 1 x Ø50-Ø40
Lado / Side	3 x Ø40-Ø32 + 2 x Ø25-Ø20

No enlazable / No linkable
Norma / Norm: **EN62208**



- Marco y base en ABS
- Ventana transparente en PC
- Incluye tapones interiores para IP

- Frame and base in ABS
- Windows transparent in PC
- Screw taps included for IP

Es posible la instalació placa metálica
It is posible installing a metal plate (Ref. Item **PL-3953**)



Ref. Item **3954**

SOPORTES METÁLICOS ACQUA COMBI / METAL SUPPORTS ACQUA COMBI

Soportes metálicos ACQUA COMBI / Metal supports ACQUA COMBI



Ref. / Item	Soportes metálicos para: Metal support for:
150039980	3951 / 3952 / 3961 / 3962 / 3967 / 3968



1000 (h) x 420 (w)

Ref. / Item	Soportes metálicos para: Metal support for:
150039981	3977 / 3978 / 3979



850 (h) x 420 (w)

Ref. / Item	Soportes metálicos para: Metal support for:
150039982	3952 / 3962 / 3968 / 3970



850 (h) x 720 (w)

Ref. / Item	Soportes metálicos para: Metal support for:
150039983	2 x 3952 / 2 x 3962 / 2 x 3968 / 2 x 3970

ACCESORIOS / ACCESSORIES

		ACCESORIOS / ACCESSORIES	
		Ref. / Item	Descripción / Description
	3915	3915	Placa con toma IP54 16A-250V~ Cover with socket IP54 16A-250V~ <i>(Para toma francesa IP54 16A-250V~ - Ref. 3922) (Cover with french socket IP54 16A-250V~ - Item 3922)</i>
	3916	3916	Placa con toma IP67 16A-250V~ Cover with socket IP67 16A-250V~ <i>(Para toma francesa, consultar) (Cover with french socket, please consult us)</i>
	3919	3919	Placa con paro de emergencia contacto NO Cover with emergency push button NO contact
	3909	3909	Placa adaptadora para tomas de cuadro de salida recta 63A Adaptor cover for 63A straight panel socket
	3901	3901	Placa ciega pretroquelada Pre die-cut blind cover
	3902	3902	Placa universal tomas 16A / 32A IP44/67 Universal cover for sockets 16A / 32A IP44/67
	3905	3905	Placa para toma de corriente de cuadro 50x50 Cover for panel sockets outlets 50x50
	3907	3907	Placa universal doble para tomas 16A / 32A IP44/67 Universal double cover for sockets 16A / 32A IP44/67
	3918	3918	Placa ciega doble pretroquelada Pre die-cut double blind cover
	3923	3923	Placa ciega Blind cover
	3903	3903	Racord de unión Link
	SPTC-4	SPTC-4	Regleta de neutro y tierra 2 x (2x16 mm²) + 2 x (4x10 mm²) Neutral and earth terminal 2 x (2x16 mm²) + 2 x (4x10 mm²)
	SPTA-12	SPTA-12	Regleta de neutro y tierra 2x16 mm² + 12x10 mm² Neutral and earth terminal 2x16 mm² + 12x10 mm²
	RG-12	RG-12	Regleta de neutro y tierra 2x16 mm² + 12x10 mm² Neutral and earth terminal 2x16 mm² + 12x10 mm²
	3900	3900	Cerradura metálica Metal lock
	3910	3910	Accesorio para fijar a pared Accessory for wall mounting
	3911	3911	Tapones interiores Intern screw taps
	3917	3917	Asa Handle
	150039570	150039570	Cierre metálico Metal lock
	150039980	150039980	Soporte metálico Metal feet
	150039981	150039981	Soporte metálico Metal feet
	150039982	150039982	Soporte metálico Metal feet
	150039983	150039983	Soporte metálico Metal feet

CAJAS / BOXES																											
3927	3950	3951	3974	3952	3977	3957	3958	3959	3928	3960	3961	3975	3962	3978	3963	3966	3967	3968	3969	3970	3979	3973	3964	3955	3956	3953	3954
									•	•	•	•	•	•	•	•											
									•	•	•	•	•	•	•	•											
									•	•	•	•	•	•	•	•											
									•	•	•	•	•	•	•	•											
									•	•	•	•	•	•	•	•											
																	•	•	•								
																	•	•	•								
		•	•	•	•	•	•	•	•	•	•	•	•	•	•	•	•	•	•	•	•	•	•	•	•	•	•
	•	•	•	•	•	•	•	•	•	•	•	•	•	•	•	•	•	•	•	•	•	•	•	•	•	•	•
									•	•	•	•	•	•	•	•											

8.2 CAJAS INDUSTRIALES CABLEADAS IP65
CABLED INDUSTRIAL ENCLOSURES IP65

- Gama modulable según sus necesidades de instalación
 - Sistema de sujeción de tomas de corriente universal (admite el 90% de las tomas del mercado)
 - Facilidad y rapidez de montaje
 - Diseñadas para su utilización en entornos industriales asegurando una alta resistencia a los agentes externos
- Modular range accordingly to your needs
 - Universal clamping system for flange sockets (accepts the 90% of the flange sockets of the market)
 - Easy and fast of assembly
 - Designed for its use in industrial environments, ensuring a high resistance to external agents

Gama completa de cajas industriales totalmente cableadas o electrificadas según sus necesidades de instalación. Ponemos a su disposición nuestro servicio de ingeniería para adaptar el producto según sus requerimientos técnicos, no dude en exponernos sus ideas.

Full range of industrial boxes cabled and equipped accordingly to your installation needs. Our engineering service is at your disposal for the adaptation of the product to your technical requirements. Don't hesitate to send us your requests.



El primer software para la configuración de cuadros de obra según sus necesidades
The first software for the configuration of industrial enclosures in accordance with your requests



Configuración de cuadro modo libre o según REBT 2002
Free combination of enclosure

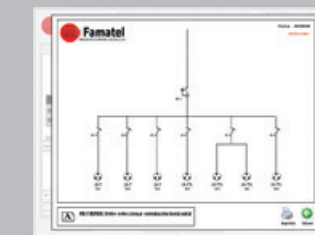

Esquema eléctrico "on line"
Electric diagram on line



Presupuesto "on line"
Budget on line

CAJAS INDUSTRIALES CABLEADAS IP44 / CABLED INDUSTRIAL BOXES IP44

Cajas 6 módulos IP44 / Boxes 6 modules IP44

1 12

Ref. / Item	3 Tomas / Sockets IP44						
	16A				32A		
	2P+T	3P+T	3P+T+N	2P+TTL	2P+T	3P+T	3P+T+N
				SCHUKO 220V			
6401	--	--	--	3	--	--	--
6402	3	--	--	--	--	--	--
6403	1	--	--	2	--	--	--
6404	2	--	--	1	--	--	--
6406	2	1	--	--	--	--	--
6407	2	--	--	--	--	1	--
6408	1	--	1	1	--	--	--
6409	1	--	--	1	--	--	1
6410	2	--	--	--	--	--	1

Norma / Norm: EN62208
Otras configuraciones consultar / Other configurations please consult us

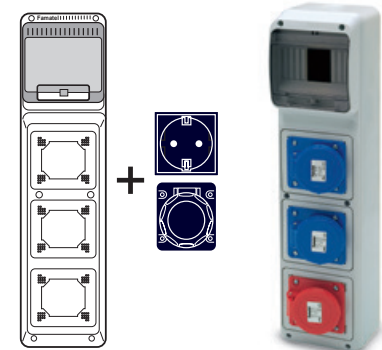

Ref./Item 3960 Ref./Item 6406

Cajas 8 módulos IP44 / Boxes 8 modules IP44

1 4

Ref. / Item	4 Tomas / Sockets IP44						
	16A				32A		
	2P+T	3P+T	3P+T+N	2P+TTL	2P+T	3P+T	3P+T+N
				SCHUKO 220V			
6501	--	--	--	4	--	--	--
6502	2	--	--	2	--	--	--
6503	2	1	--	1	--	--	--
6504	--	1	--	2	--	1	--
6505	--	2	--	2	--	--	--
6506	--	--	--	2	--	2	--
6507	--	--	2	2	--	--	--
6508	--	--	--	2	--	--	2
6509	--	--	1	2	--	--	1
6510	1	1	--	2	--	--	--
6511	2	--	2	--	--	--	--
6512	2	--	--	--	--	--	2

Norma / Norm: EN62208
Otras configuraciones consultar / Other configurations please consult us

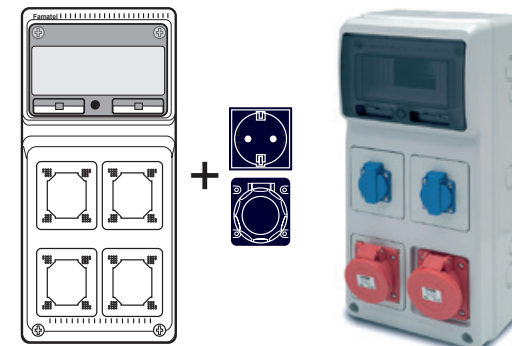

Ref./Item 3961 Ref./Item 6504

Cajas 16 módulos IP44 / Boxes 16 modules IP44

1 3

Ref. / Item	6 Tomas / Sockets IP44						
	16A				32A		
	2P+T	3P+T	3P+T+N	2P+TTL	2P+T	3P+T	3P+T+N
				SCHUKO 220V			
6601	2	--	--	4	--	--	--
6602	--	2	--	2	--	2	--
6603	2	2	--	2	--	--	--
6604	--	--	2	2	--	--	2
6605	--	2	--	2	--	2	--
6606	2	--	2	--	--	--	2

Norma / Norm: EN62208
Otras configuraciones consultar / Other configurations please consult us

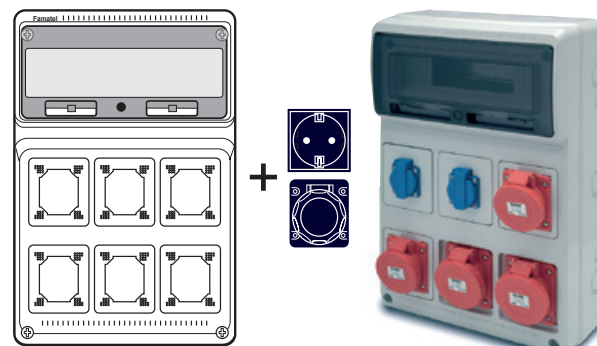

Ref./Item 3962 Ref./Item 6602

CAJAS INDUSTRIALES CABLEADAS IP44 / CABLED INDUSTRIAL BOXES IP44

Cajas 9 módulos IP44 / Boxes 9 modules IP44

1 4

Ref. / Item	Tomas / Sockets IP44					
	16A			32A		63A
	3P+T	3P+T+N	2P+TTL	3P+T	3P+T+N	3P+T+N
			SCHUKO 220V			
3957.1	1	--	2	--	--	--
3957.2	--	--	2	1	--	--
3957.3	--	--	2	--	--	--
3957.4	--	--	4	--	--	--
3957.5	--	--	--	--	--	1
3957.7	--	1	2	--	--	--
3957.8	--	--	2	--	1	--
3958.9	2	--	--	--	--	--

Norma / Norm: EN62208
Otras configuraciones consultar / Other configurations please consult us

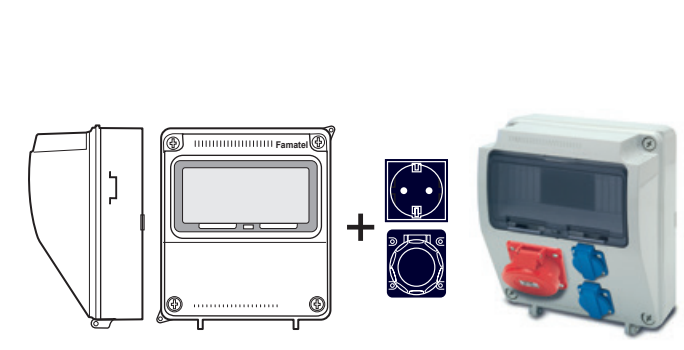

Ref./Item 3957 Ref./Item 3957.1

Cajas 9 módulos IP44 / Boxes 9 modules IP44

1 4

Ref. / Item	Tomas / Sockets IP44					
	16A			32A		63A
	3P+T	3P+T+N	2P+TTL	3P+T	3P+T+N	3P+T+N
			SCHUKO 220V			
3958.1	1	--	2	1	--	--
3958.2	2	--	2	--	--	--
3958.3	--	--	2	2	--	--
3958.4	--	1	2	--	1	--
3958.5	--	2	2	--	--	--
3958.6	--	--	2	--	2	--

Norma / Norm: EN62208
Otras configuraciones consultar / Other configurations please consult us

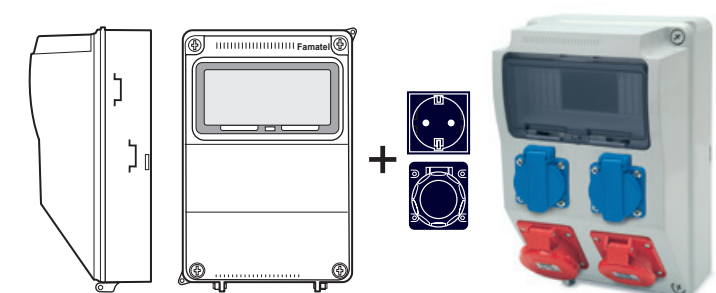

Ref./Item 3958 Ref./Item 3958.1

CAJAS INDUSTRIALES CABLEADAS IP65 / CABLED INDUSTRIAL BOXES IP65

Cajas 8 módulos IP65 / Boxes 9 modules IP65



Ref. / Item	2 Tomas interbloccantes / Interlocked sockets IP67						
	16A				32A		
	2P+T	3P+T	3P+T+N	2P+TTL	2P+T	3P+T	3P+T+N
				SCHUKO			
	220V	400V	400V	220V	220V	400V	400V
6201	2	--	--	--	--	--	--
6202	--	2	--	--	--	--	--
6203	1	--	1	--	--	--	--

Norma / Norm: EN62208
Otras configuraciones consultar / Other configurations please consult us

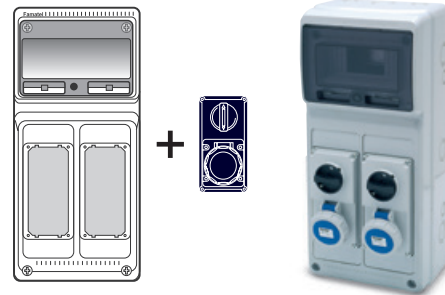

Ref./Item 3967

Ref./Item 6201

Cajas 16 módulos IP65 / Boxes 16 modules IP65



Ref. / Item	3 Tomas interbloccantes / Interlocked sockets IP65						
	16A				32A		
	2P+T	3P+T	3P+T+N	2P+TTL	2P+T	3P+T	3P+T+N
				SCHUKO			
	220V	400V	400V	220V	220V	400V	400V
6301	3	--	--	--	--	--	--
6302	2	1	--	--	--	--	--
6303	2	--	1	--	--	--	--
6304	1	1	1	--	--	--	--
6305	1	--	--	--	--	1	1
6306	1	1	--	--	--	--	1

Norma / Norm: EN62208
Otras configuraciones consultar / Other configurations please consult us

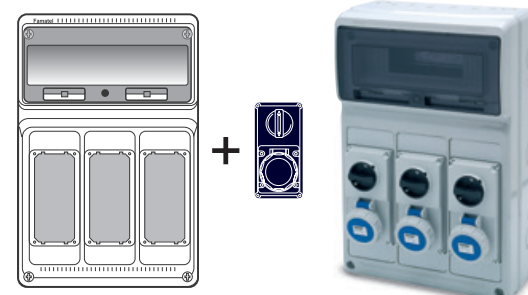

Ref./Item 3968

Ref./Item 6301

CAJAS INDUSTRIALES CABLEADAS IP65 / CABLED INDUSTRIAL BOXES IP65

Cajas 16 módulos IP65 / Boxes 16 modules IP65



Ref. / Item	4 Tomas interbloccantes / Interlocked sockets IP67						
	16A				32A		
	2P+T	3P+T	3P+T+N	2P+TTL	2P+T	3P+T	3P+T+N
				SCHUKO			
	220V	400V	400V	220V	220V	400V	400V
6901	2	2	--	--	--	--	--
6902	2	1	--	--	--	1	--
6903	3	1	--	--	--	--	--
6904	3	--	--	--	--	1	--
6905	4	--	--	--	--	--	--

Norma / Norm: EN62208 / EN60439-4
Otras configuraciones consultar / Other configurations please consult us

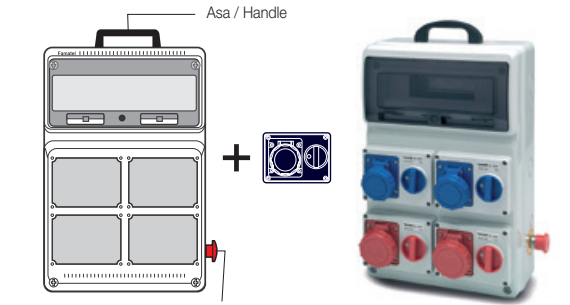

Ref./Item 3970

Seta de emergencia
Emergency push button

Ref./Item 6901

Cajas 32 módulos IP65 / Boxes 32 modules IP65



Ref. / Item	3 Tomas interbloccantes / Interlocked sockets IP67						
	16A				32A		
	2P+T	3P+T	3P+T+N	2P+TTL	2P+T	3P+T	3P+T+N
				SCHUKO			
	220V	400V	400V	220V	220V	400V	400V
6051	1	1	--	--	--	1	--
6052	--	1	1	--	--	--	1

Norma / Norm: EN62208 / EN60439-4
Otras configuraciones consultar / Other configurations please consult us

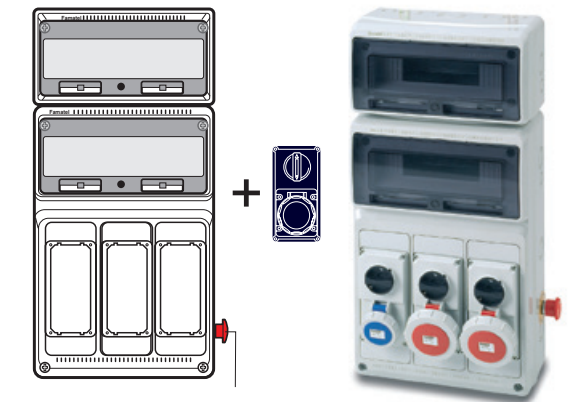

Ref./Item 3968+39064

Seta de emergencia
Emergency push button

Ref./Item 6051

Cajas 32 módulos IP65 / Boxes 32 modules IP65



Ref. / Item	3 Tomas interbloccantes / Interlocked sockets IP67						
	16A				32A		
	2P+T	3P+T	3P+T+N	2P+TTL	2P+T	3P+T	3P+T+N
				SCHUKO			
	220V	400V	400V	220V	220V	400V	400V
6053	3	--	--	2	--	--	--
6054	1	1	--	2	--	--	1

Norma / Norm: EN62208 / EN60439-4
Otras configuraciones consultar / Other configurations please consult us

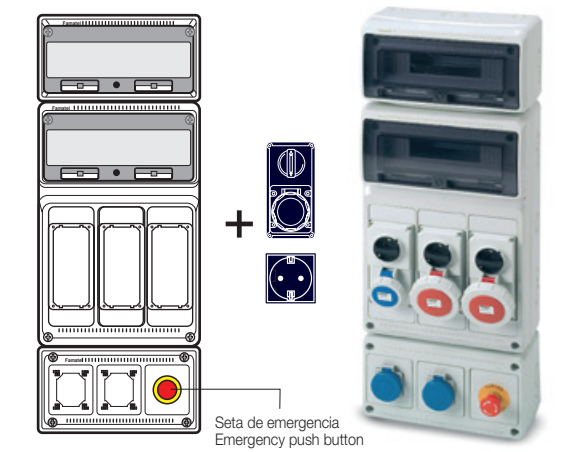

Ref./Item 3968+39064+3953

Seta de emergencia
Emergency push button

Ref./Item 6054

CAJAS INDUSTRIALES CABLEADAS CON PROTECCIONES / CABLED INDUSTRIAL BOXES WITH PROTECTIONS

Caja cableada con protecciones / Cabled box with protections Ref. Item 6405

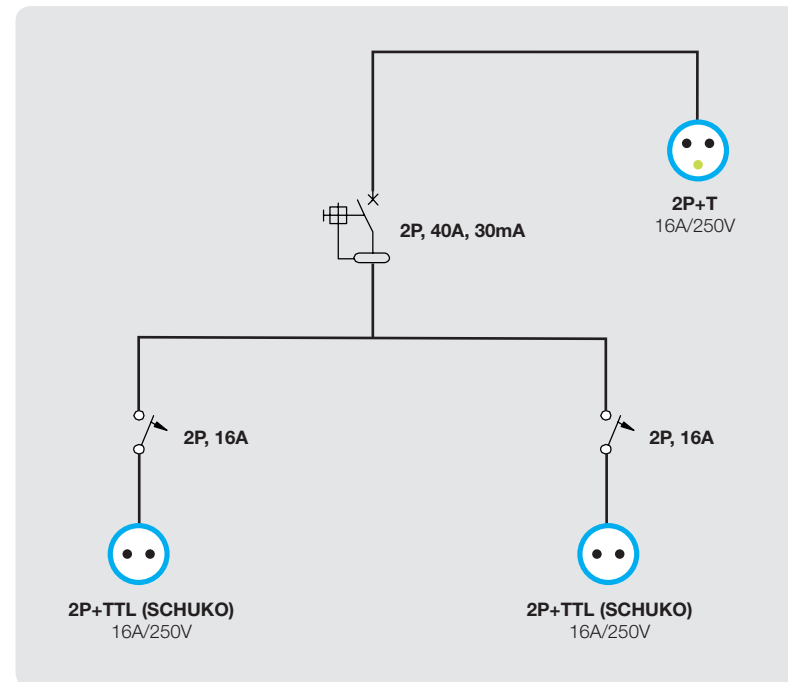

Ref. Item 6405

Norma / Norm: EN62208 / EN61439-2

Caja cableada con protecciones / Cabled box with protections Ref. Item 6020

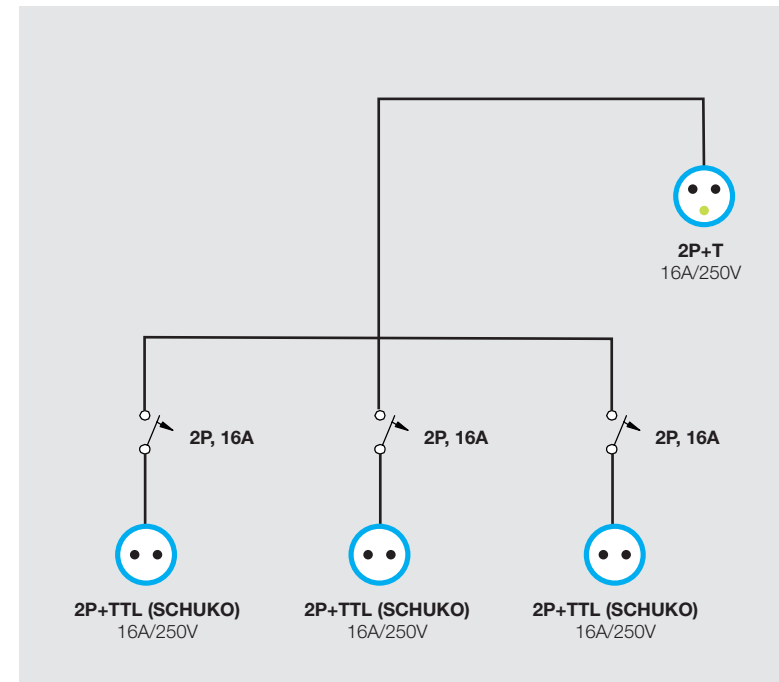

Ref. Item 6020

Norma / Norm: EN62208 / EN61439-2

Caja cableada con protecciones / Cabled box with protections Ref. Item 6412

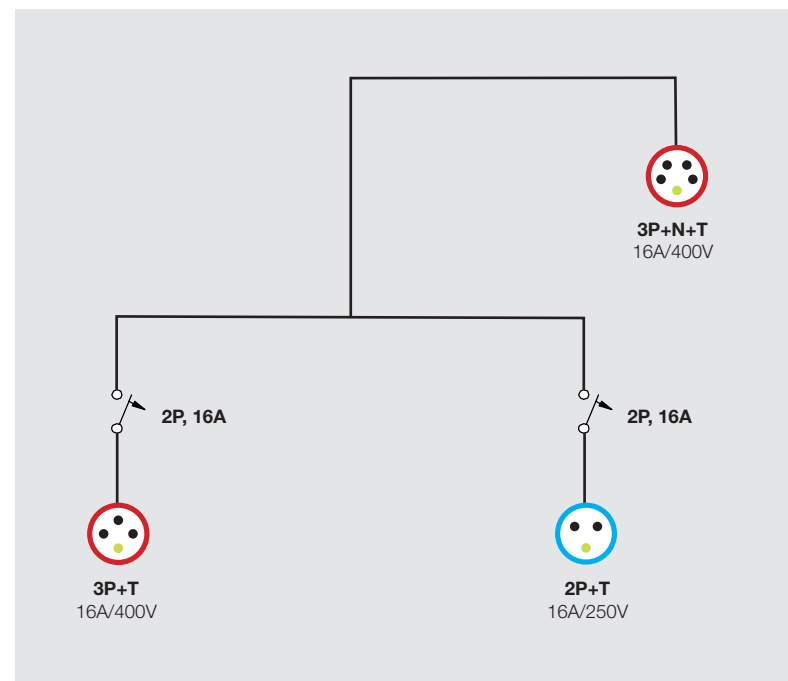

Ref. Item 6412

Norma / Norm: EN62208 / EN61439-2

Caja cableada con protecciones / Cabled box with protections Ref. Item 6021

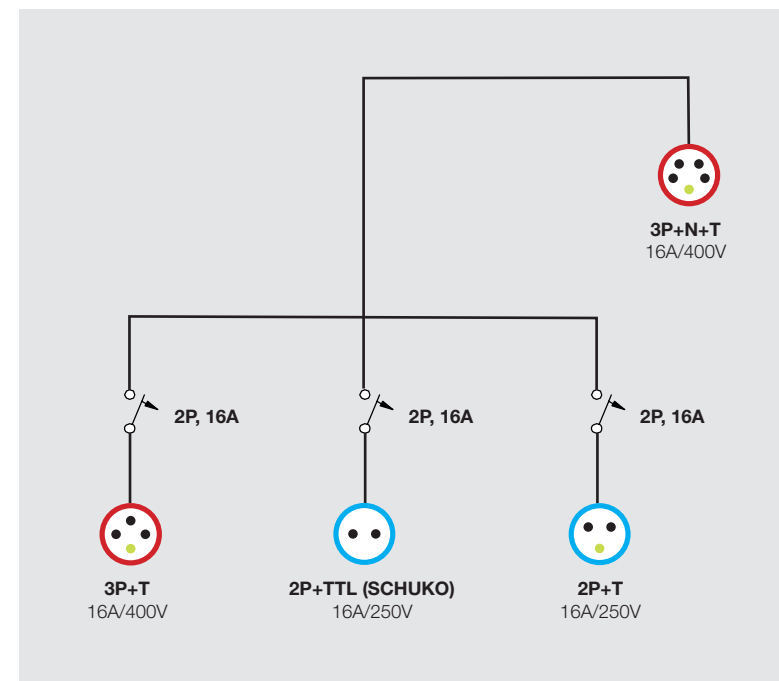

Ref. Item 6021

Norma / Norm: EN62208 / EN61439-2

CAJAS INDUSTRIALES CABLEADAS CON PROTECCIONES / CABLED INDUSTRIAL BOXES WITH PROTECTIONS

Caja cableada con protecciones / Cabled box with protections Ref. Item 6701

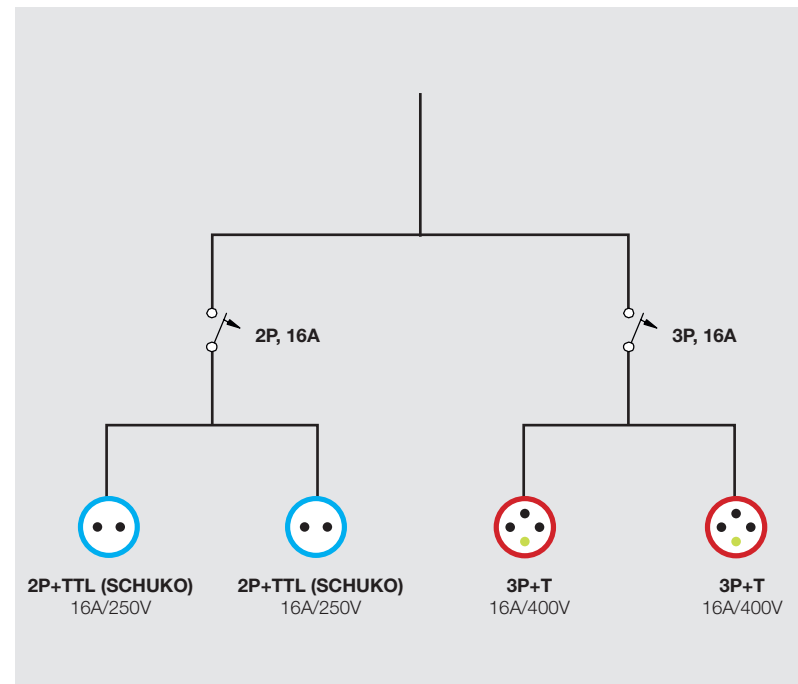

15 m cable H07RN-F 5x4 mm² + Clavija/Plug IEC 3P+N+T 16A/400V
Norma / Norm: EN62208 / EN61439-2



Ref. Item 6701

Caja cableada con protecciones / Cabled box with protections Ref. Item 6703

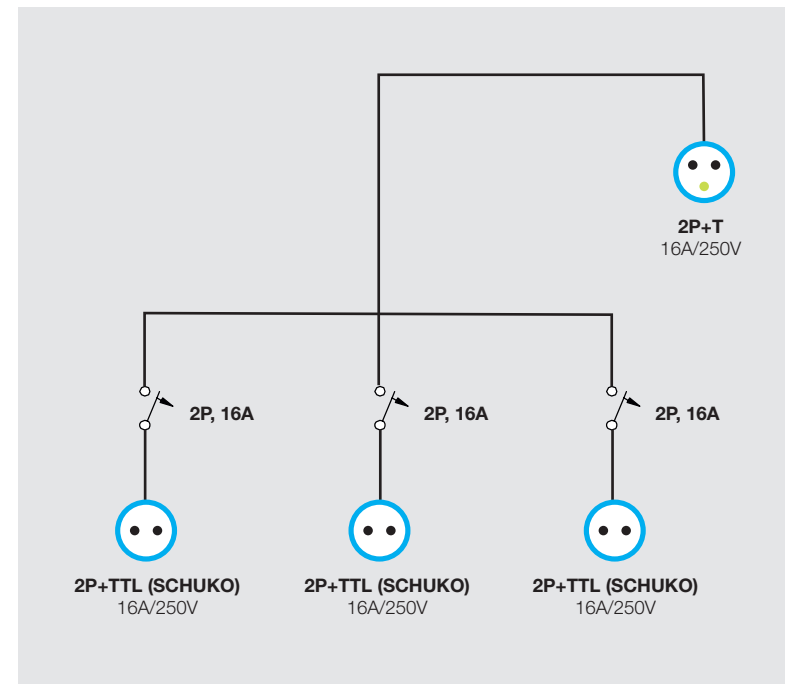

Norma / Norm: EN62208 / EN61439-2



Ref. Item 6703

Caja cableada con protecciones / Cabled box with protections Ref. Item 6702

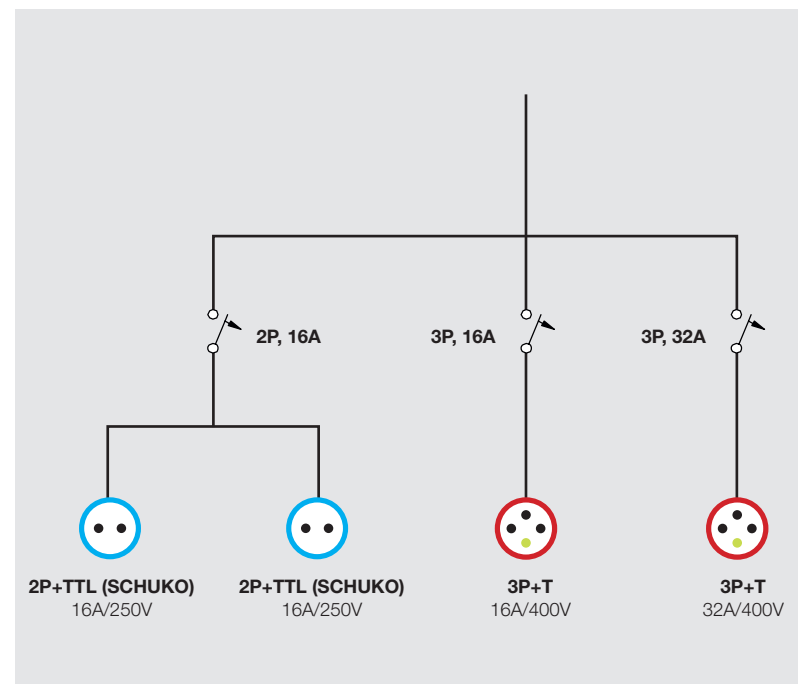

15 m cable H07RN-F 5x6 mm² + Clavija/Plug IEC 3P+N+T 32A/400V
Norma / Norm: EN62208 / EN61439-2



Ref. Item 6702

Caja cableada con protecciones / Cabled box with protections Ref. Item 6704

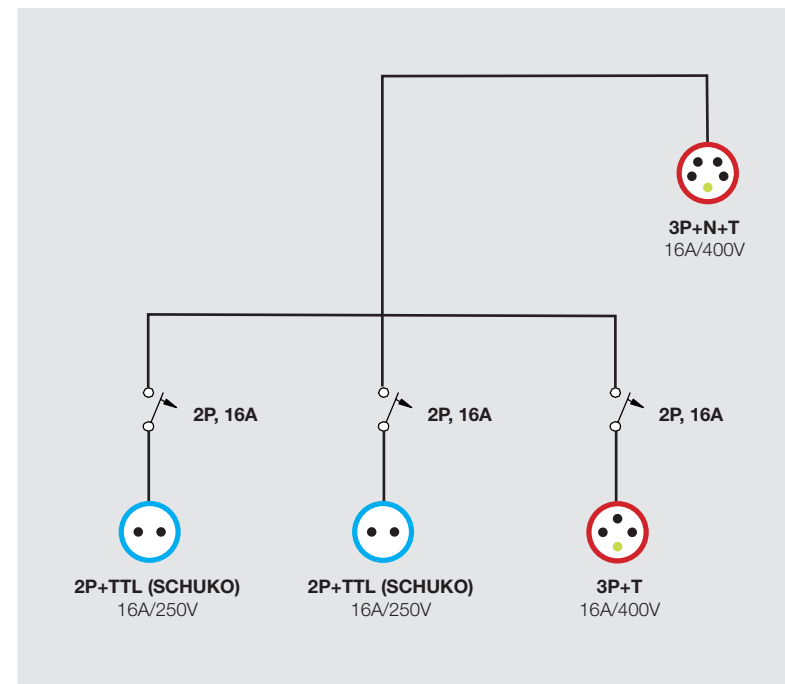

Norma / Norm: EN62208 / EN61439-2



Ref. Item 6704

CAJAS INDUSTRIALES CABLEADAS CON PROTECCIONES / CABLED INDUSTRIAL BOXES WITH PROTECTIONS

Caja cableada con protecciones / Cabled box with protections Ref. Item 6705

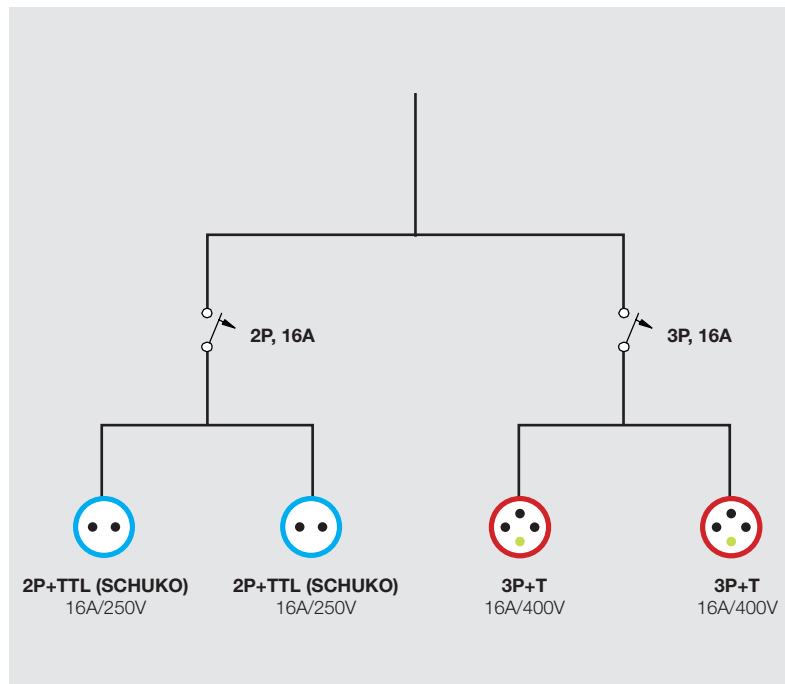

15 m cable H07RN-F 5x4 mm² + Clavija/Plug IEC 3P+N+T 16A/400V
Norma / Norm: EN62208 / EN61439-2



Ref. Item 6705

CAJAS INDUSTRIALES CABLEADAS CON PROTECCIONES / CABLED INDUSTRIAL BOXES WITH PROTECTIONS

Caja cableada con protecciones / Cabled box with protections Ref. Item 3957.11

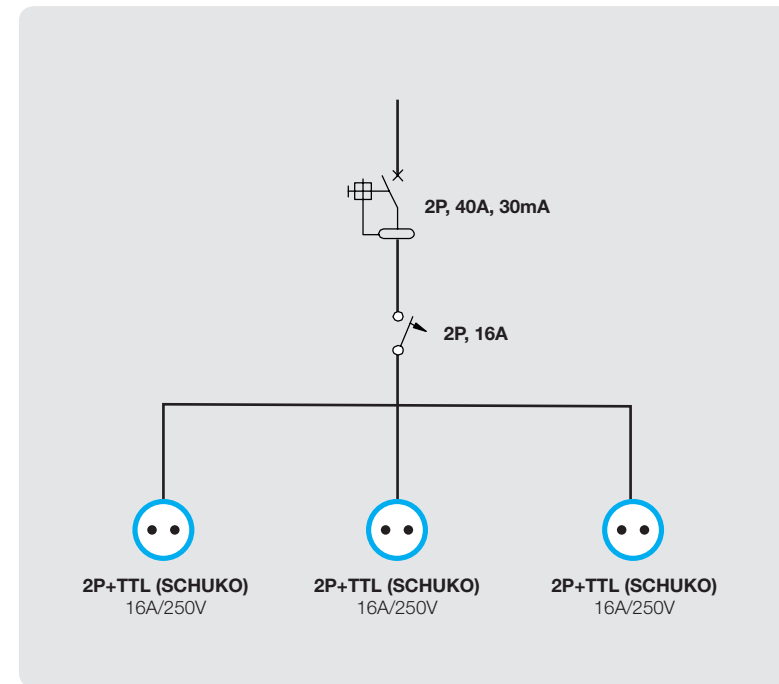

15 m cable H05W-F 3x2,5 mm² + Clavija/Plug SCHUKO 16A/250V
Norma / Norm: EN62208 / EN61439-2



Ref. Item 3957.11

Caja cableada con protecciones / Cabled box with protections Ref. Item 6706

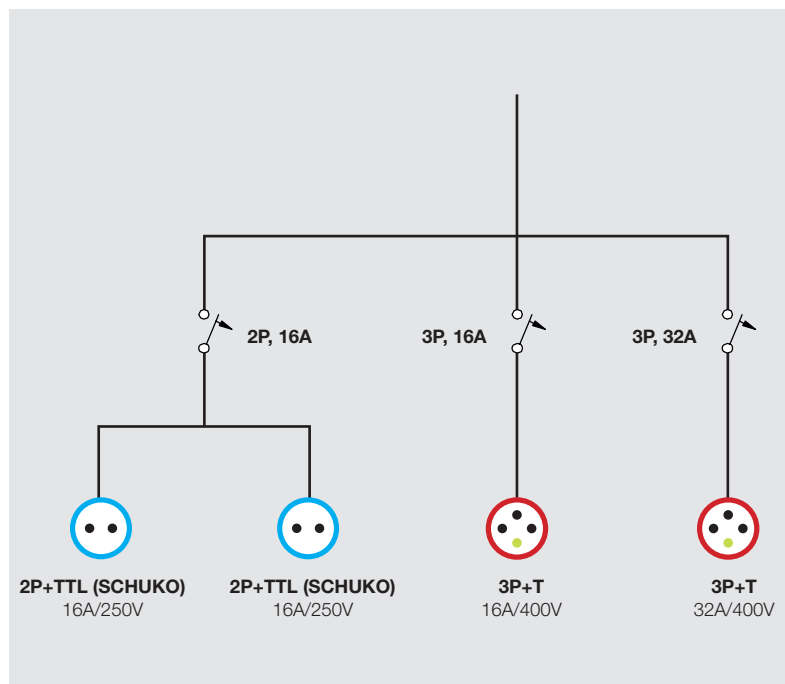

15 m cable H07RN-F 5x6 mm² + Clavija/Plug IEC 3P+N+T 32A/400V
Norma / Norm: EN62208 / EN61439-2



Ref. Item 6706

Caja cableada con protecciones / Cabled box with protections Ref. Item 6151

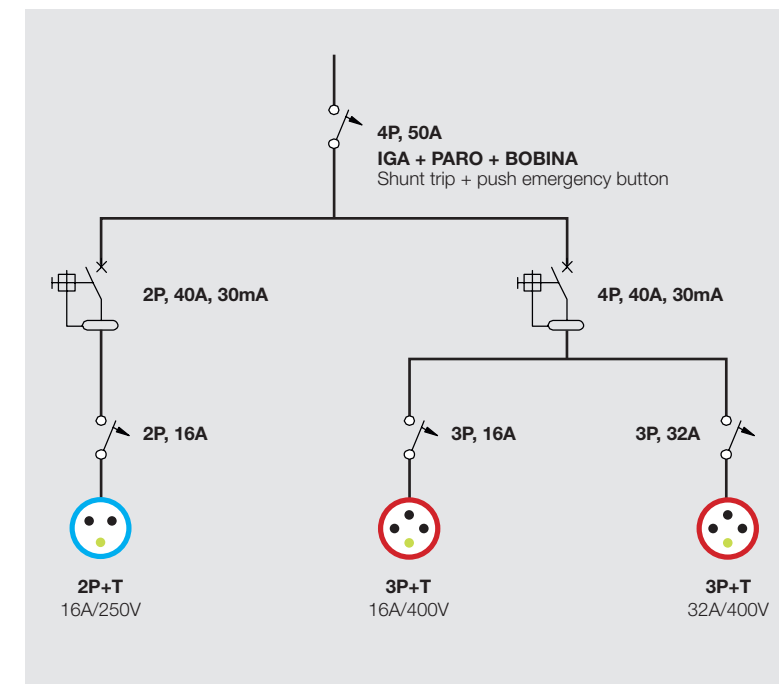

Norma / Norm: EN62208 / EN60439-4



Ref. Item 6151

CAJAS INDUSTRIALES CABLEADAS CON PROTECCIONES / CABLED INDUSTRIAL BOXES WITH PROTECTIONS

Caja cableada con protecciones / Cabled box with protections Ref. Item 6152

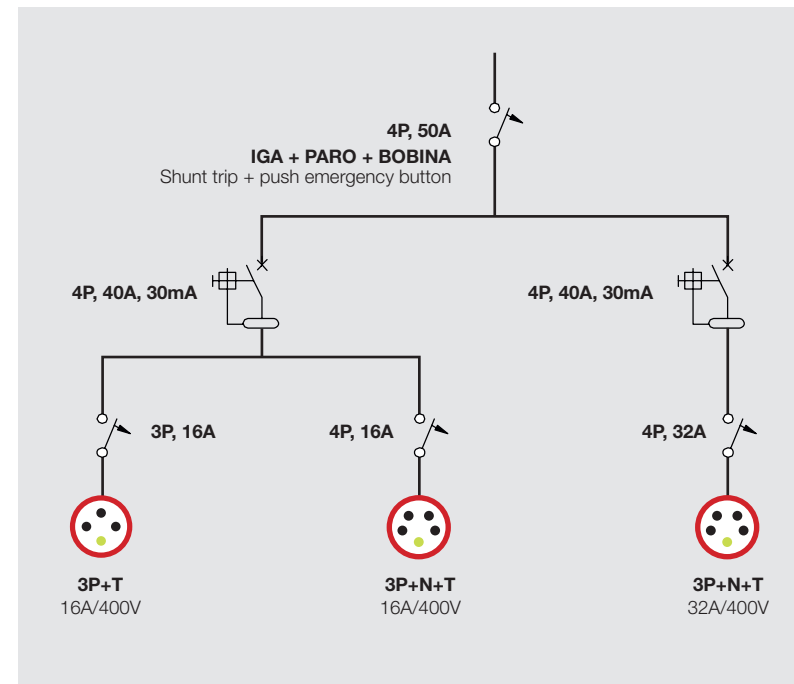

Ref. Item 6152

Norma / Norm: EN62208 / EN60439-4

Caja cableada con protecciones / Cabled box with protections Ref. Item 6154

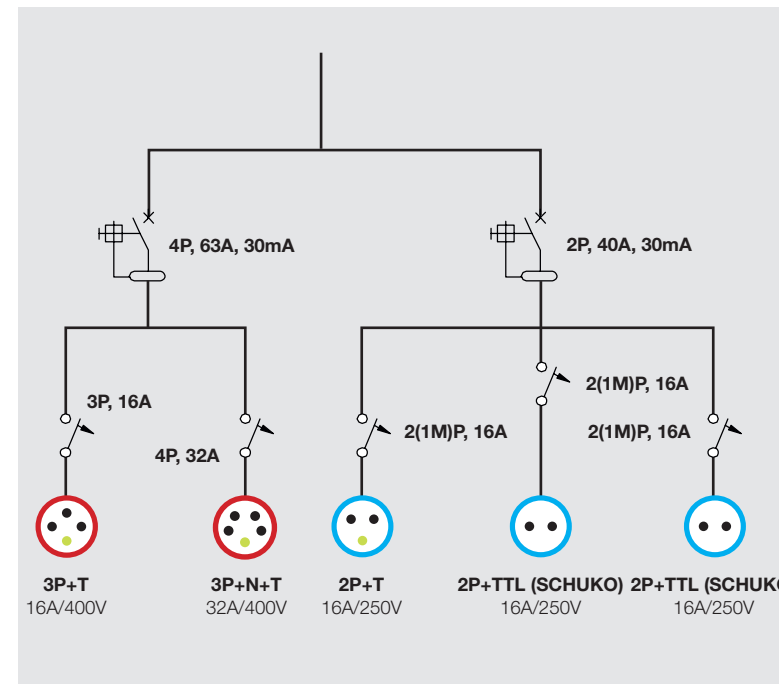

Ref. Item 6154

Norma / Norm: EN62208 / EN60439-4

Caja cableada con protecciones / Cabled box with protections Ref. Item 6153

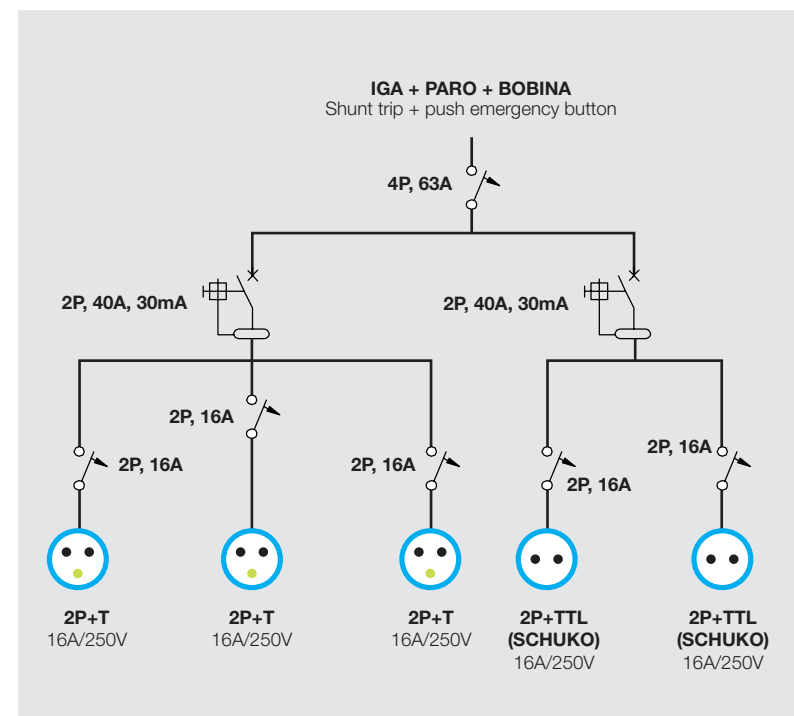

Ref. Item 6153

Norma / Norm: EN62208 / EN60439-4

Caja cableada con protecciones / Cabled box with protections Ref. Item 6155

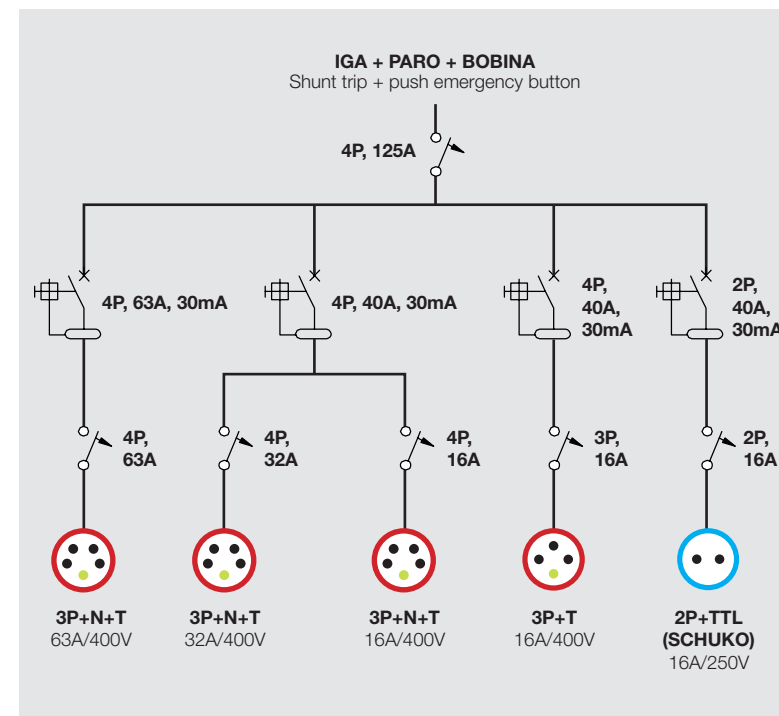

Ref. Item 6155

Norma / Norm: EN62208 / EN60439-4

CONFIGURACIÓN DE CUADROS DE OBRA / CONFIGURATION OF INDUSTRIAL ENCLOSURES

El primer software para la configuración de cuadros de obra según sus necesidades. Solicite cualquier combinación, nuestro departamento técnico está a su disposición.

The first software for the configuration of industrial enclosures in accordance with your request. Request any combination, our technical department is at your disposal.

1º

8 módulos 8 módulos 16 módulos

Elija el tipo de caja
Select the box

+

2º

16A 16A

Seleccione las tomas
Select the sockets

+

3º

Seleccione las protecciones
Select the protections devices

AcQUAsoft
Programa de cálculo on line de armarios eléctricos industriales
Reglamento BT automático
Original CD software
AcQUAsoft

Famatel

Fecha: 25/05/05

RECUERDE: Debe seleccionar orientación horizontal

OFERTA ABANDONO INDUSTRIAL
Precio actualizado a 2006
Fecha: 20/06/06

DETALLE DE LOS COMPONENTES		DESCRIPCIÓN		CANTIDAD	
1	CAJA	16	16	1	1
2	CAJA	16	16	1	1
3	CAJA	16	16	1	1
4	CAJA	16	16	1	1
5	CAJA	16	16	1	1
6	CAJA	16	16	1	1
7	CAJA	16	16	1	1
8	CAJA	16	16	1	1
9	CAJA	16	16	1	1
10	CAJA	16	16	1	1
11	CAJA	16	16	1	1
12	CAJA	16	16	1	1
13	CAJA	16	16	1	1
14	CAJA	16	16	1	1
15	CAJA	16	16	1	1
16	CAJA	16	16	1	1
17	CAJA	16	16	1	1
18	CAJA	16	16	1	1
19	CAJA	16	16	1	1
20	CAJA	16	16	1	1
21	CAJA	16	16	1	1
22	CAJA	16	16	1	1
23	CAJA	16	16	1	1
24	CAJA	16	16	1	1
25	CAJA	16	16	1	1
26	CAJA	16	16	1	1
27	CAJA	16	16	1	1
28	CAJA	16	16	1	1
29	CAJA	16	16	1	1
30	CAJA	16	16	1	1
31	CAJA	16	16	1	1
32	CAJA	16	16	1	1
33	CAJA	16	16	1	1
34	CAJA	16	16	1	1
35	CAJA	16	16	1	1
36	CAJA	16	16	1	1
37	CAJA	16	16	1	1
38	CAJA	16	16	1	1
39	CAJA	16	16	1	1
40	CAJA	16	16	1	1
41	CAJA	16	16	1	1
42	CAJA	16	16	1	1
43	CAJA	16	16	1	1
44	CAJA	16	16	1	1
45	CAJA	16	16	1	1
46	CAJA	16	16	1	1
47	CAJA	16	16	1	1
48	CAJA	16	16	1	1
49	CAJA	16	16	1	1
50	CAJA	16	16	1	1
51	CAJA	16	16	1	1
52	CAJA	16	16	1	1
53	CAJA	16	16	1	1
54	CAJA	16	16	1	1
55	CAJA	16	16	1	1
56	CAJA	16	16	1	1
57	CAJA	16	16	1	1
58	CAJA	16	16	1	1
59	CAJA	16	16	1	1
60	CAJA	16	16	1	1
61	CAJA	16	16	1	1
62	CAJA	16	16	1	1
63	CAJA	16	16	1	1
64	CAJA	16	16	1	1
65	CAJA	16	16	1	1
66	CAJA	16	16	1	1
67	CAJA	16	16	1	1
68	CAJA	16	16	1	1
69	CAJA	16	16	1	1
70	CAJA	16	16	1	1
71	CAJA	16	16	1	1
72	CAJA	16	16	1	1
73	CAJA	16	16	1	1
74	CAJA	16	16	1	1
75	CAJA	16	16	1	1
76	CAJA	16	16	1	1
77	CAJA	16	16	1	1
78	CAJA	16	16	1	1
79	CAJA	16	16	1	1
80	CAJA	16	16	1	1
81	CAJA	16	16	1	1
82	CAJA	16	16	1	1
83	CAJA	16	16	1	1
84	CAJA	16	16	1	1
85	CAJA	16	16	1	1
86	CAJA	16	16	1	1
87	CAJA	16	16	1	1
88	CAJA	16	16	1	1
89	CAJA	16	16	1	1
90	CAJA	16	16	1	1
91	CAJA	16	16	1	1
92	CAJA	16	16	1	1
93	CAJA	16	16	1	1
94	CAJA	16	16	1	1
95	CAJA	16	16	1	1
96	CAJA	16	16	1	1
97	CAJA	16	16	1	1
98	CAJA	16	16	1	1
99	CAJA	16	16	1	1
100	CAJA	16	16	1	1

8.3 ARMARIOS DE OBRA
DISTRIBUTION ENCLOSURES FOR CONSTRUCTION SITES

Todos estos armarios se sirven con "Paro de emergencia exterior".
La bobina de estos armarios es de "emisión", pudiendo solicitar de "mínima".
Accesorios: candado de cierre exterior, ruedas de arrastre.
Puede solicitar cualquier otra configuración. Plazo de entrega: 24 horas.

All enclosures are supplied with an external push button.
Accessories: external padlock, wheels. Request personal combinations.

- Alta resistencia al impacto
 - Cierres en inoxidable
 - Pulsador de emergencia exterior
 - Portabilidad
- High impact resistance
 - Inox metal locks
 - External emergency push button
 - Portability

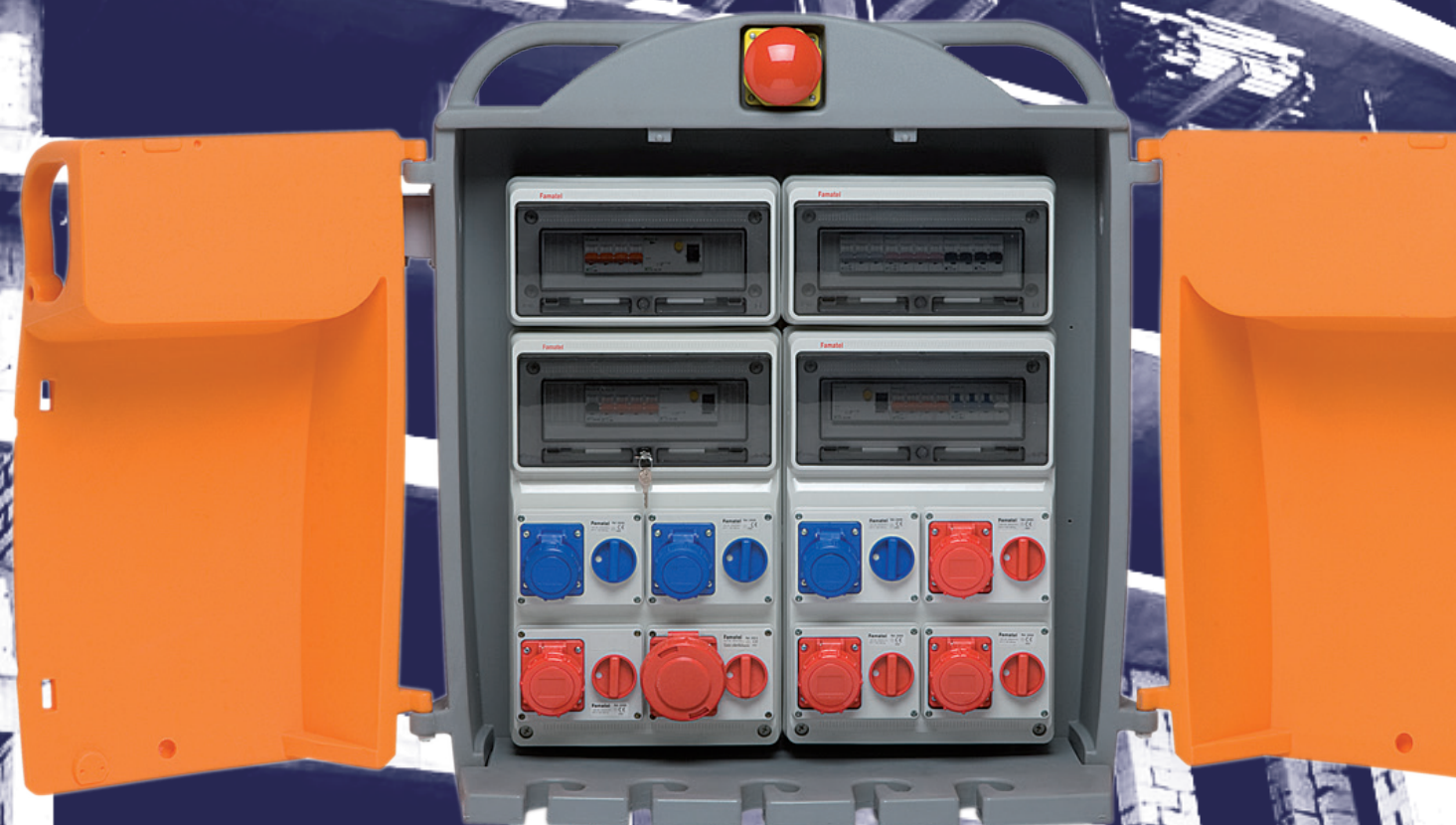

Paro de emergencia externo
External emergency push button



Posibilidad de incorporar ruedas
Optional wheels



Cierres externos metálicos
External metal lock



Toma de tensión del cuadro externo
External voltage socket



Múltiples combinaciones según sus necesidades
Multiple combinations in accordance with your requirements



ARMARIOS DE OBRA / DISTRIBUTION ENCLOSURES FOR CONSTRUCTION SITES

Caja / box - Ref. Item **3980**

1

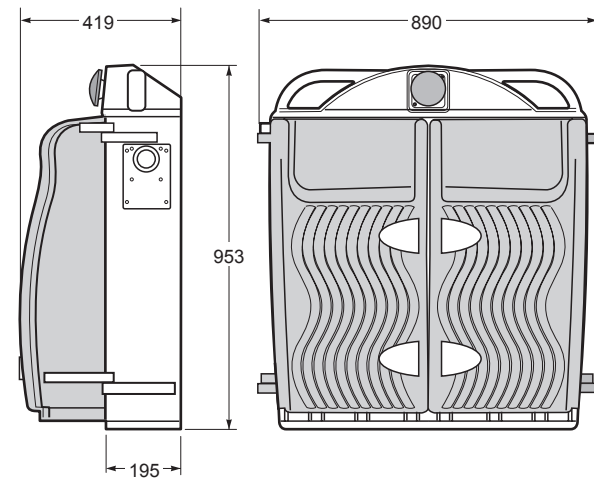

Dimensiones / Dimensions	
Altura / Height	953
Ancho / Width	890
Profundidad / Deep	419
Weight (kg)	18

Norma / Norm: EN61439-1 / EN60439-3 / EN60439-4



- Incluye paro de emergencia externo
- Include external emergency push button



Ref. Item **3980**

Caja / box - Ref. Item **3980P**

1

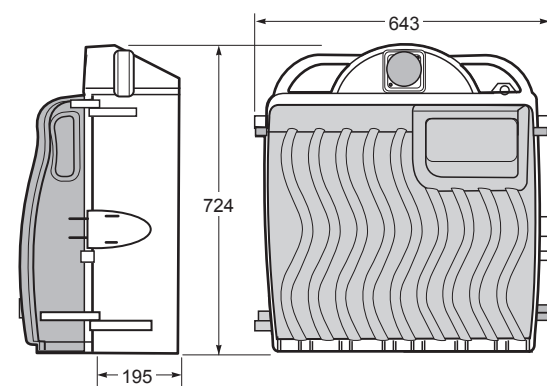

Dimensiones / Dimensions	
Altura / Height	724
Ancho / Width	643
Profundidad / Deep	419
Weight (kg)	11

Norma / Norm: EN61439-1 / EN60439-3 / EN60439-4



- Incluye paro de emergencia externo
- Include external emergency push button



Ref. Item **3980P**

ACCESORIOS / ACCESSORIES

Soporte armario 3980
Box support 3980 - Ref. Item **3981**

1



Ref. Item **3981**

Soporte armario 3980P
Box support 3980P - Ref. Item **3982**

1



Ref. Item **3982**

Ruedas para armario 3980
Wheels for enclosure 3980 - Ref. Item **3983**

1



Ref. Item **3983**

Candado para precinto
Padlock for precinct - Ref. Item **3984**

1



Ref. Item **3984**

POSIBLES MONTAJES / ASSEMBLING CONFIGURATION

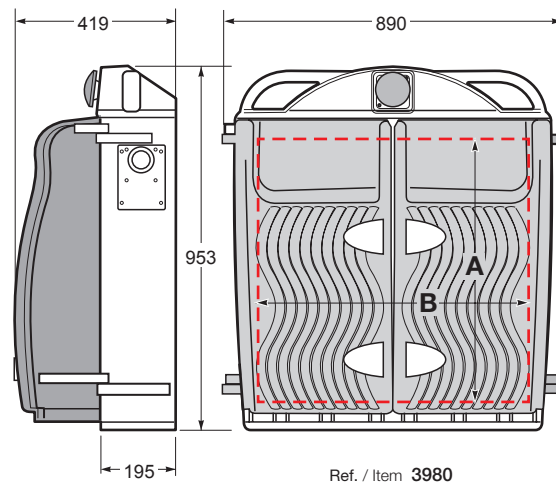

Capacidad para cajas Acqua-Combi Capacity for Acqua-Combi Enclosures		
Opciones / Options	Ref. / Item	Nº de
1	3962	2
2	3962 + 3964	2 + 2
3	3962 + 3968	1 + 1
4	3962 + 3970	1 + 1
5	3968	2
6	3970 + 3964	2 + 2

Ref. / Item 3980

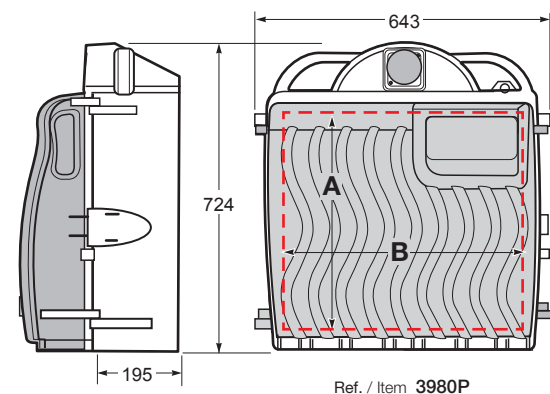

Capacidad para cajas Acqua-Combi Capacity for Acqua-Combi Enclosures		
Opciones / Options	Ref. / Item	Nº de
1	3962	1
2	3970	1
3	3968	1
4	3961	2
5	3961 + 3967	1 + 1
6	3967	2

Ref. / Item 3980P

Para otras configuraciones, consultar / Please consult for another configurations



1º Elije el tipo de caja
Select the box

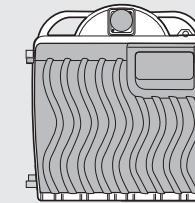

2º

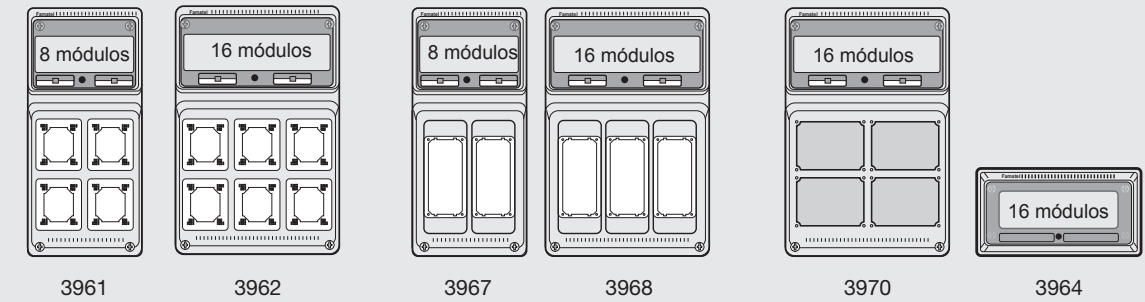

3º Seleccione las tomas
Select the sockets

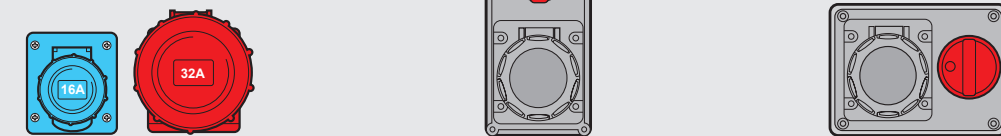

4º Seleccione las protecciones
Select the protection devices



En 24 h tiene su presupuesto
You will receive the quotation in 24 h





8.4 CAJAS DE GOMA RUBBER BOXES

IMPACT

Las nuevas cajas de goma IMPACT están diseñadas para instalaciones que requieran una alta protección a los agentes externos así como una gran resistencia al impacto. Fabricadas en goma butílica están diseñadas para su aplicación en ambientes industriales con una alta exigencia técnica. Disponen de un amplio espacio de cableado y su diseño exterior asegura una perfecta protección a la entrada de agua, polvo, aceites, etc... Están disponibles desde 10 a 18 módulos.

The new IMPACT rubber boxes are designed for installations that require high protection from external agents as well as high impact resistance. Manufactured in butyl rubber are designed for application in industrial environments with a high technical requirement. They have a wide space of wiring and its external design ensures a perfect protection to the entrance of water, dust, oils, etc... They are available from 10 to 18 modules.



Ventana transparente de policarbonato con cierre por muelle
Cover unbreakable transparente polycarbonate with spring closure for modular switches



Armadura de doble aislamiento en goma butílica, garantizando un IP65 y una alta resistencia al impacto, IK10
Framework double insulated in hard butyl rubber, guarantees an IP65 and a high impact resistance, IK10



3 modelos disponibles (10, 12, 18 módulos). Corte de módulos según necesidad.
3 available models (10, 12, 18 modules). Cut modules according to your need.



Carril DIN incorporado y posibilidad de sujeción en la base de bornes, placas metálicas, etc.
DIN rail included and possibility to fix on the base terminal bars, metal plates, etc.

- Fabricadas en goma butílica
- Máxima resistencia a aceites, ácidos, gasolina, disolventes industriales, etc
- 3 modelos de 10, 12 y 18 módulos
- Amplio espacio para el cableado
- Excepcional resistencia al envejecimiento
- IK10 muy alta resistencia al impacto

- Manufactured in butyl rubber
- Maximum resistance to oils, acids, gasoline and industrial solvents
- 3 models in 10, 12 and 18 modules
- Extensive wiring space
- Exceptional resistance to aging
- IK10 high impact resistance

CAJAS DE DISTRIBUCIÓN DE GOMA BUTÍLICA / SOLID STRONG BUTYL RUBBER DISTRIBUTION BOXES

Cajas de goma / Rubber boxes - Ref. Item **23310**

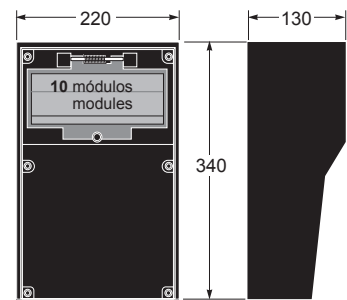

Dimensiones / Dimensions	
Altura / Height	340
Ancho / Width	220
Profundidad / Deep	130

No enlazable / No linkable
Norma / Norm: EN62208 / EN60670-1

Estabilidad térmica / Dimensional stability: **-20° +80°**

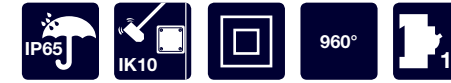

- Caja robusta de caucho butílico con aislamiento total, autoextinguible máxima resistencia a los aceites, ácidos, gasolina y disolventes industriales, y una excepcional resistencia al envejecimiento.
- Venta a transparente de policarbonato 10 Módulos con cierre por resorte de acero inoxidable AISI 304 y junta de estanqueidad para garantizar un grado de protección IP65 con los tornillos roscados. La cubierta de la armadura tiene una sello en relieve especial que garantiza el doble aislamiento y el grado de protección.
- Completely in strong Butyl rubber with total isolation, self-extinguishing, maximum resistance to oils, acids, gasoline and industrial solvents, and an exceptional resistance to aging.
- Unbreakable Polycarbonate windows, 10 modules, shock resistant with spring and stainless pin ASI. Protection degree up to IP65. Rubber basis with gasket flush-mounted around the perimeter; Rubber covers with respective gasket in relief that, by connection with the rubber basis guarantees the double insulation and degree of protection.



Ref. Item **23310**

Cajas de goma / Rubber boxes - Ref. Item **23311**

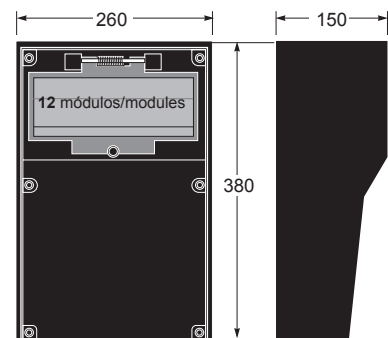

Dimensiones / Dimensions	
Altura / Height	380
Ancho / Width	260
Profundidad / Deep	150

No enlazable / No linkable
Norma / Norm: EN62208 / EN60670-1

Estabilidad térmica / Dimensional stability: **-20° +80°**



- Caja robusta de caucho butílico con aislamiento total, autoextinguible máxima resistencia a los aceites, ácidos, gasolina y disolventes industriales, y una excepcional resistencia al envejecimiento.
- Ventana transparente de policarbonato 12 Módulos con cierre por resorte de acero inoxidable AISI 304 y junta de estanqueidad para garantizar un grado de protección IP65 con los tornillos roscados. La cubierta de la armadura tiene una sello en relieve especial que garantiza el doble aislamiento y el grado de protección.
- Completely in strong Butyl rubber with total isolation, self-extinguishing, maximum resistance to oils, acids, gasoline and industrial solvents, and an exceptional resistance to aging.
- Unbreakable Polycarbonate windows, 12 modules, shock resistant with spring and stainless pin ASI. Protection degree up to IP65. Rubber basis with gasket flush-mounted around the perimeter; Rubber covers with respective gasket in relief that, by connection with the rubber basis guarantees the double insulation and degree of protection.



Ref. Item **23311**

Cajas de goma / Rubber boxes - Ref. Item **23312**

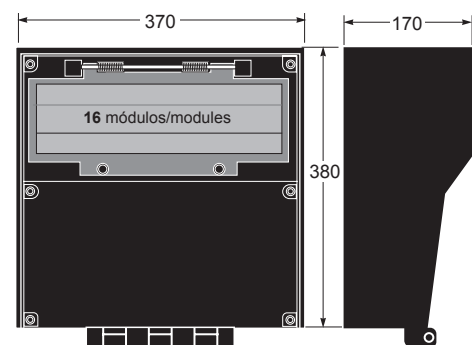

Dimensiones / Dimensions	
Altura / Height	380
Ancho / Width	370
Profundidad / Deep	170

No enlazable / No linkable
Norma / Norm: EN62208 / EN60670-1

Estabilidad térmica / Dimensional stability: **-20° +80°**



- Caja robusta de caucho butílico con aislamiento total, autoextinguible máxima resistencia a los aceites, ácidos, gasolina y disolventes industriales, y una excepcional resistencia al envejecimiento.
- Ventana transparente de policarbonato 18 Módulos con cierre por resorte de acero inoxidable AISI 304 y junta de estanqueidad para garantizar un grado de protección IP65 con los tornillos roscados. La cubierta de la armadura tiene una sello en relieve especial que garantiza el doble aislamiento y el grado de protección.
- Completely in strong Butyl rubber with total isolation, self-extinguishing, maximum resistance to oils, acids, gasoline and industrial solvents, and an exceptional resistance to aging.
- Unbreakable Polycarbonate windows, 18 modules, shock resistant with spring and stainless pin ASI. Protection degree up to IP65. Rubber basis with gasket flush-mounted around the perimeter; Rubber covers with respective gasket in relief that, by connection with the rubber basis guarantees the double insulation and degree of protection.



Ref. Item **23312**

CAJAS DE DISTRIBUCIÓN DE GOMA BUTÍLICA CABLEADAS / CABLED SOLID STRONG BUTYL RUBBER DISTRIBUTION BOXES

Cajas de goma / Rubber boxes - Ref. Item **23310**

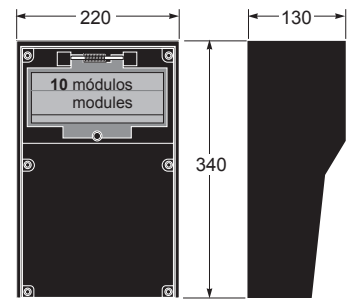

Ref / Item	Nº schuko	IP67 16A 3p+T+N 380-440V	IP67 32A 3p+T+N 380-440V	IP67 63A 3p+T+N 380-440V	IP67 125A 3p+T+N 380-440V
23310.1	4	--	--	--	--
23310.2	1	1	--	--	--
23310.3	1	--	1	--	--
23310.4	--	--	--	1	--
23310.5	--	--	--	--	1

Norma / Norm: EN62208 / EN60439-1 / EN60439-4

Cajas de goma / Rubber boxes - Ref. Item **23311**

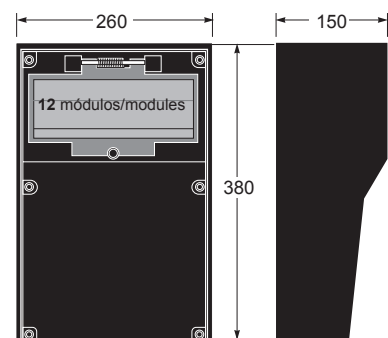

Ref / Item	Nº schuko	IP67 16A 3p+T+N 380-440V	IP67 32A 3p+T+N 380-440V	IP67 63A 3p+T+N 380-440V
23311.1	6	--	--	--
23311.2	3	2	--	--
23311.3	3	--	2	--
23311.4	3	1	1	--
23311.5	--	1	1	--
23311.6	3	--	--	1
23311.7	--	1	--	1
23311.8	--	--	1	1

Norma / Norm: EN62208 / EN60439-1 / EN60439-4

Cajas de goma / Rubber boxes - Ref. Item **23312**

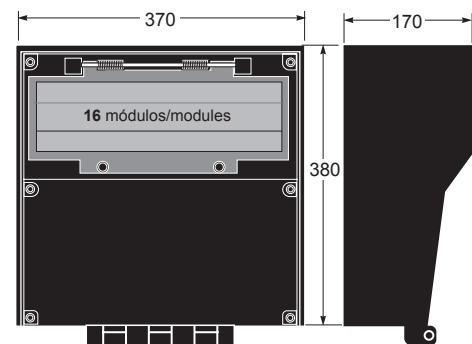

Ref / Item	Nº schuko	IP67 16A 3p+T+N 380-440V	IP67 32A 3p+T+N 380-440V	IP67 63A 3p+T+N 380-440V	IP67 125A 3p+T+N 380-440V
23312.1	10	--	--	--	--
23312.2	5	3	--	--	--
23312.3	5	--	2	--	--
23312.4	5	2	1	--	--
23312.5	5	--	--	1	--
23312.6	--	3	--	1	--
23312.7	--	--	2	1	--
23312.8	--	2	1	1	--
23312.9	4	--	--	--	1

Norma / Norm: EN62208 / EN60439-1 / EN60439-4

- Montajes estandar; para otras configuraciones soliciten presupuesto indicando modelos de caja y configuración.
- Standard assembly; For other configurations please request quotation, indicating models of boxes and it's configuration.

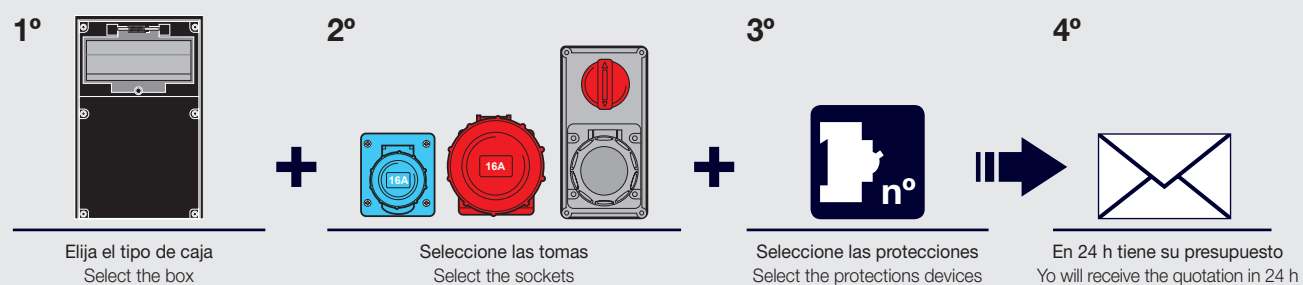

ACCESORIOS / ACCESSORIES

Asa / Handle - Ref. Item **3917**



Soporte / Support - Ref. Item **1833**

- Soportes metálico para fijación a pared para modelos: 23310 / 23311
- Metallic supports to fix on the wall for models: 23310 / 23311



Soporte / Support - Ref. Item **1834**

- Soporte metálico para fijación a pared para modelo: 23312
- Metallic support to fix on the wall for model: 23312



Soporte regletas + regleta
Terminal bar support + Terminal bar - Ref. Item **SPTC-4**

- Soporte regletas de neutro y tierra para ref. 3904, 3904-T y serie Acqua Combi + 2 regletas RG-04 (2x16 mm² + 4x10 mm²).
- Neutral and earth terminal bar support for item 3904, 3904-T and Acqua Combi serie + 2 terminal bar RG-04 (2x16 mm² + 4x10 mm²).



8.5 ARMARIOS ESTANCOS TERMOPLÁSTICOS IP65
WATERTIGHT ENCLOSURES IP65

- Protección al UV, corrosión y al salitre
- Estabilidad dimensional -25°C+85°C
- Autoextinguible UL94HB
- Incluye placa metálica galvanizada 1,2 mm

- UV, Corrosion and salinity protection
- Operating temperature -25°C+85°C
- Flame-retardant UL94HB
- Include mounting galvanized metal plate 1.2 mm

MAGNA está formada por 6 modelos hasta una medida máxima de 800x600. Pensadas para su aplicación en el sector residencial e industrial por su versatilidad y grado de protección a los agentes externos. Incorporan una placa metálica que permite la instalación de cualquier equipo eléctrico y de control. Destaca la posibilidad de incorporar un equipo porta módulos así como la instalación de una segunda puerta de seguridad. Su sistema de apertura por llave triangular permite un rápido y fácil acceso al interior de la instalación.

MAGNA is composed for 6 models up to a maximum measurement of 800x600. Designed for application in the residential and industrial sector for its versatility and degree of protection to external agents. Incorporate a metal plate that allows the installation of any electrical and control equipment. It emphasizes the possibility of incorporating a porta-modules as well as the installation of a second security door. Its system of opening by triangular key allows a quick and easy access to the interior of the installation.



Incluyen accesorios de fijación que garantizan la protección IP65
Wall fixing accessories guaranteeing IP65 protection degree



Bisagras reforzadas con ejes metálicos.
Reinforced hinges



Llave de cierre 1/4 de giro, posibilidad de incorporar cerradura metálica
1/4 turn plastic key

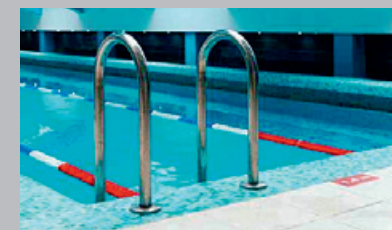

Piscinas
Swimming pool



Bodegas
Wine cellar



Campos de cultivo
Farmland

ARMARIOS MAGNA IP65 / MAGNA ENCLOSURES IP65

Armario / Enclosure - Ref. Item **39123**

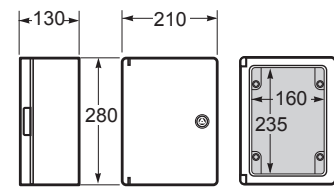

Dimensiones externas / External dimensions	
Altura / Height	280
Ancho / Width	210
Profundidad / Deep	130
Dimensiones internas / Internal dimensions	
Altura / Height	235
Ancho / Width	160
Profundidad / Deep	123

Normas / Norms: EN 61439-1 / EN 60439-3 / EN 62208



- Marco y puerta en ABS
- Sistema de cierre 1/4 de giro
- Incluye placa metálica galvanizada
- Door and base in ABS
- 1/4 turn plastic key
- Galvanized metallic plate included



Ref. Item **39123**

Armario / Enclosure - Ref. Item **39134**

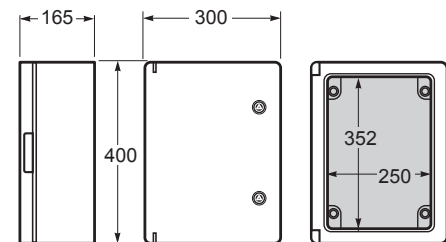

Dimensiones externas / External dimensions	
Altura / Height	400
Ancho / Width	300
Profundidad / Deep	165
Dimensiones internas / Internal dimensions	
Altura / Height	352
Ancho / Width	250
Profundidad / Deep	158

Normas / Norms: EN 61439-1 / EN 60439-3 / EN 62208



- Marco y puerta en ABS
- Sistema de cierre 1/4 de giro
- Incluye placa metálica galvanizada
- Door and base in ABS
- 1/4 turn plastic key
- Galvanized metallic plate included



Ref. Item **39134**

Armario / Enclosure - Ref. Item **39145**

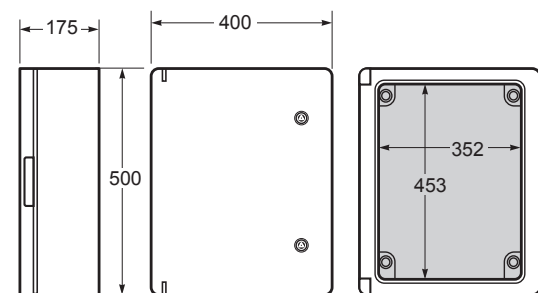

Dimensiones externas / External dimensions	
Altura / Height	500
Ancho / Width	400
Profundidad / Deep	175
Dimensiones internas / Internal dimensions	
Altura / Height	453
Ancho / Width	352
Profundidad / Deep	168

Normas / Norms: EN 61439-1 / EN 60439-3 / EN 62208



- Marco y puerta en ABS
- Sistema de cierre 1/4 de giro
- Incluye placa metálica galvanizada
- Door and base in ABS
- 1/4 turn plastic key
- Galvanized metallic plate included



Ref. Item **39145**

Armario / Enclosure - Ref. Item **39146**

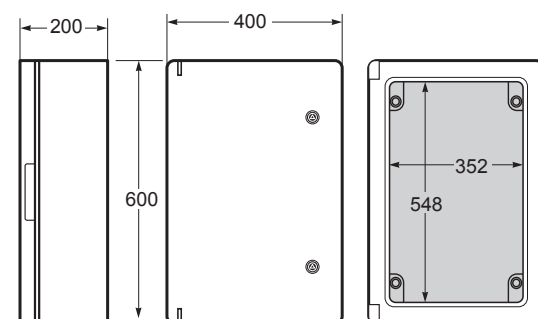

Dimensiones externas / External dimensions	
Altura / Height	600
Ancho / Width	400
Profundidad / Deep	200
Dimensiones internas / Internal dimensions	
Altura / Height	548
Ancho / Width	352
Profundidad / Deep	193

Normas / Norms: EN 61439-1 / EN 60439-3 / EN 62208



- Marco y puerta en ABS
- Sistema de cierre 1/4 de giro
- Incluye placa metálica galvanizada
- Door and base in ABS
- 1/4 turn plastic key
- Galvanized metallic plate included



Ref. Item **39146**

ARMARIOS MAGNA IP65 / MAGNA ENCLOSURES IP65

Armario / Enclosure - Ref. Item **39157**

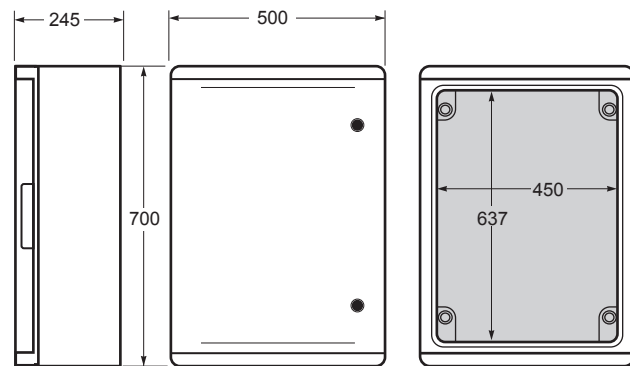

Dimensiones externas / External dimensions	
Altura / Height	700
Ancho / Width	500
Profundidad / Deep	245

Dimensiones internas / Internal dimensions	
Altura / Height	637
Ancho / Width	450
Profundidad / Deep	238

Normas / Norms: EN 61439-1 / EN 60439-3 / EN 62208



- Marco y puerta en ABS
- Sistema de cierre 1/4 de giro
- Incluye placa metálica galvanizada
- Door and base in ABS
- 1/4 turn plastic key
- Galvanized metallic plate included



Ref. Item **39157**

Armario / Enclosure - Ref. Item **39168**

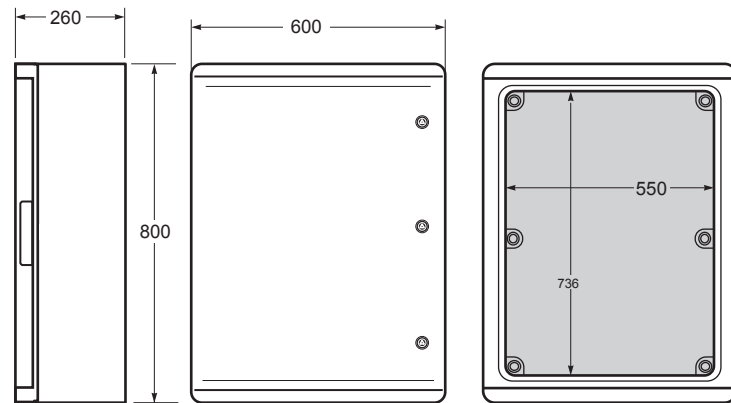

Dimensiones externas / External dimensions	
Altura / Height	800
Ancho / Width	600
Profundidad / Deep	260

Dimensiones internas / Internal dimensions	
Altura / Height	736
Ancho / Width	550
Profundidad / Deep	253

Normas / Norms: EN 61439-1 / EN 60439-3 / EN 62208



- Marco y puerta en ABS
- Sistema de cierre 1/4 de giro
- Incluye placa metálica galvanizada
- Door and base in ABS
- 1/4 turn plastic key
- Galvanized metallic plate included



Ref. Item **39168**

Rail DIN / DIN Rail

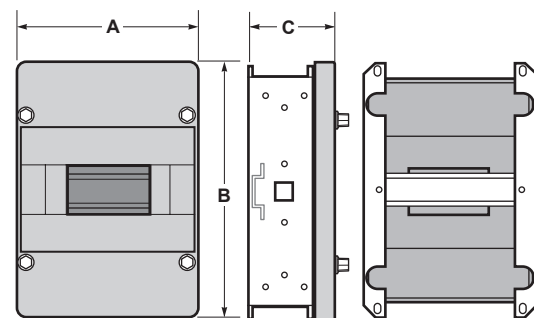

Ref. / Item	Dimensiones / dimensions		
	A	B	C
I-39123	150	229	100
I-39134	238	347	135
I-39145	342	448	145
I-39146	342	543	170
I-39157	446	627	215



Placa polyester / Polyester plate

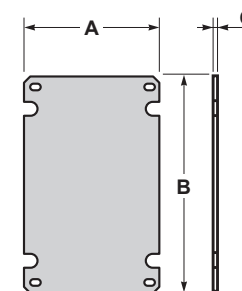

Ref. / Item	Dimensiones / dimensions		
	A	B	C
PL-39123	150	229	3
PL-39134	238	347	3
PL-39145	342	448	4
PL-39146	342	543	4
PL-39157	446	627	4
PL-39168	543	726	4



Cerradura metálica / Metal lock - Ref. Item **39120**



8.6 ARMARIOS DE SUPERFICIE IP65
WALL MOUNTED ENCLOSURES IP65

- Gama 18 a 72 módulos
- Amplio espacio cableado
- Portamódulos extraíble, fácil y rápida instalación
- Posibilidad de instalar ICP precintado
- Membrana pretrquelada IP65 que permite una fácil instalación
- From 18 to 72 modules
- Wide space for the cabling
- Removable DIN rails for an easy installation
- Possibility of installing a main power circuit breaker
- Bi-injection cable entry IP65 membrane for easy installation

La nueva gama de armarios de superficie AcquaPLUS IP65 está formada por cuatro modelos de 18 a 72 módulos con posibilidad de instalar un ICP precintado. Estos armarios están pensados para su aplicación en el sector terciario y en ambientes sujetos a polvo, humedad, etc. Destacan por su rapidez y facilidad de instalación en cualquier entorno. Su diseño ergonómico ha sido estudiado con el objetivo de facilitar el acceso al armario una vez instalado, permitiendo una fácil apertura/cierre de la puerta.

The new range of surface enclosures AcquaPLUS IP65 is composed by 4 models that go from 18 to 72 modules. These enclosures have been designed for its application in the tertiary sector and in harsh environments. Its main characteristics are the fast and easy installation as well as its ergonomic design studied to make easier the access to the enclosure once it is installed through a secure opening/closing door system.

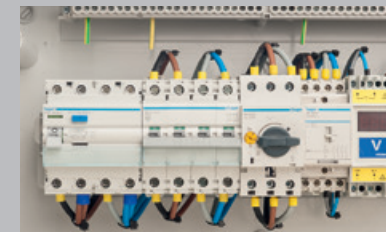

Amplio espacio para el cableado
Wide space for the cabling



Posibilidad de instalar cerradura metálica
Posibility of adapting a metal lock



Frontal y portamódulos extraíble para una fácil y rápida instalación
Front side removable for a fast and easy installation



Membrana bimaterial que permite una fácil instalación de los tubos métricos garantizando un grado de protección IP65
Bi-injection cable entry membrane that allows the installation of metric tubes and at the same time guarantee the IP65 protection



Membrana bimaterial dispuesta de pretrqueles para instalar prensaestopas
Pre-drilled bi-injection membrane for the fixation of cable glands



Membrana bimaterial dispuesta para instalar cable directamente garantizando un grado de protección IP65
Bi-injection membrane for a direct cable entry without the need to cut or drilled it guaranteeing an IP65 protection degree



Tapones protectores para garantizar el grado de protección IP65
Screw taps to guarantee the IP65 protection degree



Facilidad de apertura de la puerta
Easy door opening system

ACQUA+

Armario / Enclosure - Ref. Item **39018**

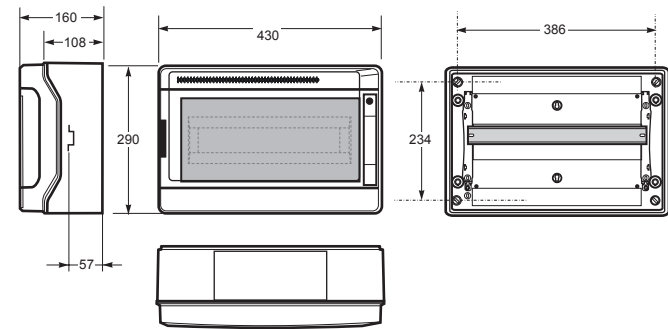

Dimensiones / Dimensions	
Altura / Height	290
Ancho / Width	430
Profundidad / Deep	160
Entradas / Entries	
Superior / Top	2x20; 8x25; 1x35
Inferior / Bottom	2x20; 8x25; 1x35
Norma / Norm: EN62208	

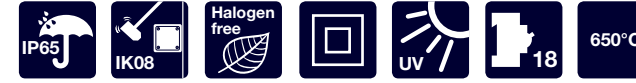

- Marco y base en ABS
- ventana transparente en PC
- Incluye tapones interiores para IP

- Frame and base in ABS
- Window transparent in PC
- Screw taps included for IP

* Incluye 1 SPT18/36 (1 Soporte rail + 2 terminales x (11x10 mm² + 11x16 mm²))
Include 1 SPT18/36 (1 Rail support + 2 terminals x (11x10 mm² + 11x16 mm²))

** Si se requieren más terminales / If you require extra terminals
Ref. SPT18/36 - Terminales / PE/N Terminal block - 2x (11x10 mm² + 11x16 mm²)



Ref. Item **39018**



Ref. Item **SPT18/36**

Armario / Enclosure - Ref. Item **39036**

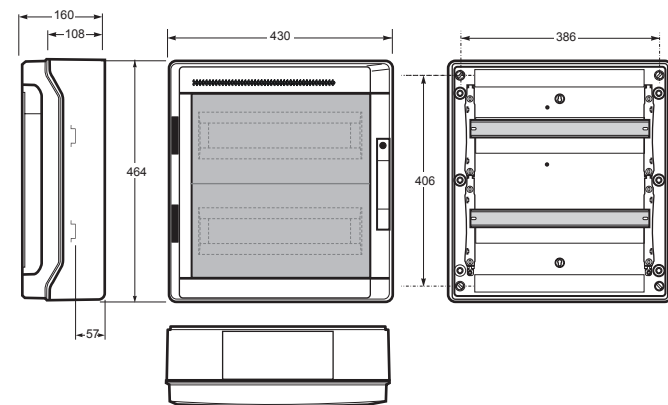

Dimensiones / Dimensions	
Altura / Height	640
Ancho / Width	430
Profundidad / Deep	160
Entradas / Entries	
Superior / Top	2x20; 8x25; 1x35
Inferior / Bottom	2x20; 8x25; 1x35
Norma / Norm: EN62208	



- Marco y base en ABS
- ventana transparente en PC
- Incluye tapones interiores para IP

- Frame and base in ABS
- Window transparent in PC
- Screw taps included for IP

* Incluye 1 SPT18/36 (1 Soporte rail + 2 terminales x (11x10 mm² + 11x16 mm²))
Include 1 SPT18/36 (1 Rail support + 2 terminals x (11x10 mm² + 11x16 mm²))

** Si se requieren más terminales / If you require extra terminals
Ref. SPT18/36 - Terminales / PE/N Terminal block - 2x (11x10 mm² + 11x16 mm²)



Ref. Item **39036**



Ref. Item **SPT18/36**

Armario / Enclosure - Ref. Item **39054**

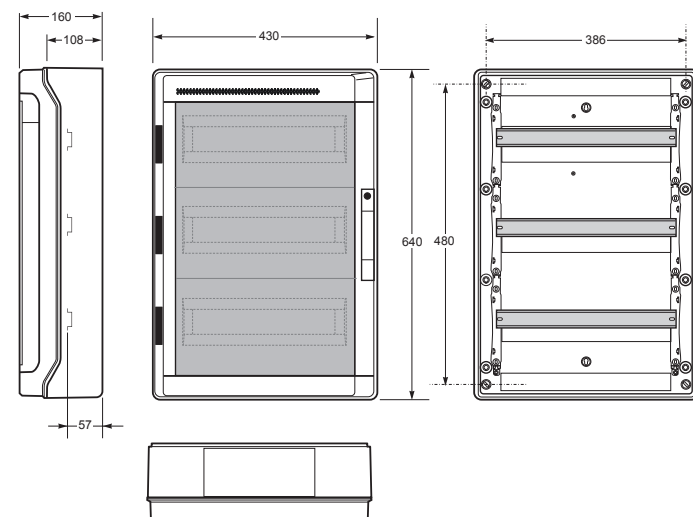

Dimensiones / Dimensions	
Altura / Height	290
Ancho / Width	430
Profundidad / Deep	160
Entradas / Entries	
Superior / Top	2x20; 8x25; 1x35
Inferior / Bottom	2x20; 8x25; 1x35
Norma / Norm: EN62208	



- Marco y base en ABS
- ventana transparente en PC
- Incluye tapones interiores para IP

- Frame and base in ABS
- Window transparent in PC
- Screw taps included for IP

* Incluye 2 SPT18/36 (2 Soporte rail + 4 terminales x (11x10 mm² + 11x16 mm²))
Include 2 SPT18/36 (2 Rail support + 4 terminals x (11x10 mm² + 11x16 mm²))

** Si se requieren más terminales / If you require extra terminals
Ref. SPT18/36 - Terminales / PE/N Terminal block - 2x (11x10 mm² + 11x16 mm²)



Ref. Item **39054**



Ref. Item **SPT18/36**

ACQUA+

Armario / Enclosure - Ref. Item **39072**

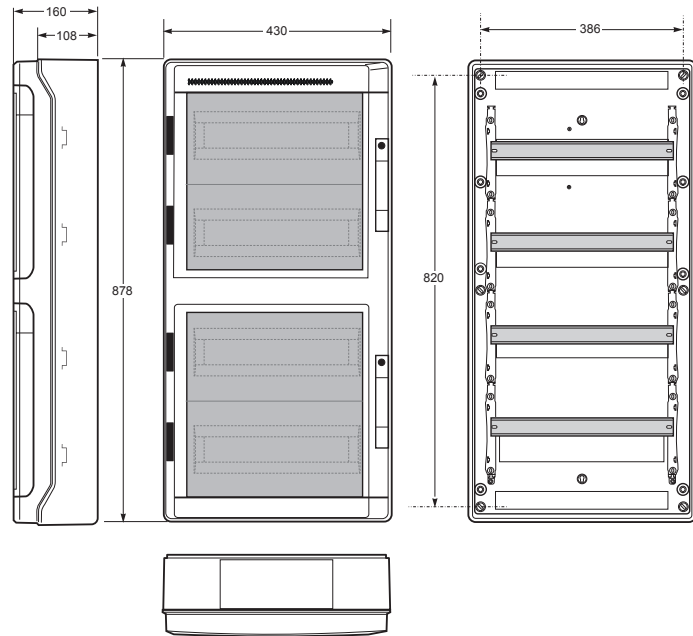

Dimensiones / Dimensions	
Altura / Height	878
Ancho / Width	430
Profundidad / Deep	160
Entradas / Entries	
Superior / Top	2x20; 8x25; 1x35
Inferior / Bottom	2x20; 8x25; 1x35
Norma / Norm: EN62208	

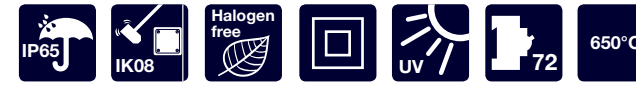

- Marco y base en ABS
- ventana transparente en PC
- Incluye tapones interiores para IP

- Frame and base in ABS
- Window transparent in PC
- Screw taps included for IP



Ref. Item **39072**



Ref. Item **SPT18/36**

* Incluye 3 SPT18/36 (3 Soporte rail + 6 terminales x (11x10 mm² + 11x16 mm²))
Include 3 SPT18/36 (3 Rail support + 6 terminals x (11x10 mm² + 11x16 mm²))

** Si se requieren más terminales / If you require extra terminals
Ref. SPT18/36 - Terminales / PE/N Terminal block - 2x (11x10 mm² + 11x16 mm²)

8.7 ARMARIOS DE SUPERFICIE IP65 - Acqua
WALL MOUNTED ENCLOSURES IP65 - Acqua

- Gama de 4 a 42 módulos.
- Amplio espacio para el cableado
- Entradas pretroqueladas para facilitar su instalación
- Posibilidad de instalar terminales neutro y tierra
- Tornillo de cierre ¼ vuelta
- Posibilidad de cerradura metálica
- From 4 to 42 modules
- Wide space for the cabling
- Pre-drilled entries for an easy installation
- Ready to install terminal blocks for neutral and earth
- ¼ turn screws
- Optional metal lock

La gama de armarios de superficie Acqua IP65 está formada por seis modelos de 4 a 42 módulos. Estos armarios están pensados para su aplicación en el sector doméstico y terciario. Están diseñados para soportar ambientes con polvo, humedad, etc. Destacan por su rapidez y facilidad de instalación en cualquier entorno. Su diseño ergonómico ha sido estudiado con el objetivo de facilitar el acceso al armario una vez instalado, permitiendo una fácil apertura/cierre de la puerta.

The new range of surface enclosures Acqua IP65 is composed by six models from 4 to 42 modules. These enclosures are thought for its application in the domestic and tertiary sector. They have been designed to support extrem environments with high levels of humidity and dust. Its easy and fast installation makes them ready to be used in any environment. Its ergonomic design has been studied with the objective of making easy the access to the enclosure once it is installed through a secure opening/closing door system.



Entradas pretroqueladas para facilitar su instalación
Pre-drilled entries for an easy installation



Amplio espacio para el cableado
Wide space for the cabling

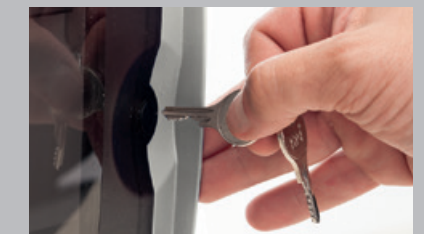

Posibilidad de instalar cerradura metálica
Optional metal lock



Cierre ergonómico para facilitar la apertura/cierre del armario
Ergonomic opening/closing system



Posibilidad de instalar terminales de neutro y tierra
Ready to install the terminal blocks for neutral and earth connection

Terminal de neutro y/o tierra
Earth/neutral bar

Entradas pretroqueladas
Knock-outs

Tornillo 1/4 vuelta precintable
Sealable 1/4 turn screw



Tapones tornillos
Screw covers

Cerradura metálica opcional
Optional metallic lock

ACQUA

Armario / Enclosure - Ref. Item **3902-T**

1 30

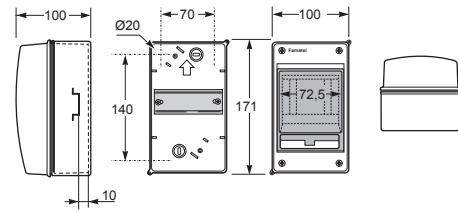

Dimensiones / Dimensions	
Altura / Height	171
Ancho / Width	100
Profundidad / Deep	100

Precintable / Sealable

Norma / Norm: **EN62208**



- Marco y base en ABS
- ventana transparente en PC
- Incluye tapones interiores para IP

- Frame and base in ABS
- Window transparent in PC
- Screw taps included for IP



Ref. Item **3902-T**

Armario / Enclosure - Ref. Item **3904-T**

1 17

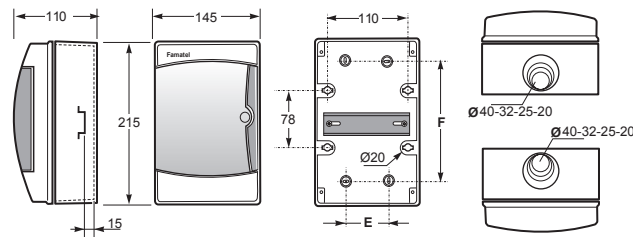

Dimensiones / Dimensions	
Altura / Height	215
Ancho / Width	145
Profundidad / Deep	110

Entradas / Entries

Superior / Top	1 x Ø20, Ø25, Ø32, Ø40
Inferior / Bottom	1 x Ø20, Ø25, Ø32, Ø40

Precintable / Sealable

Norma / Norm: **EN62208**



- Marco y base en ABS
- ventana transparente en PC
- Incluye tapones interiores para IP

- Frame and base in ABS
- Window transparent in PC
- Screw taps included for IP



Ref. Item **3904-T**

Armario / Enclosure - Ref. Item **3908-T**

1 9

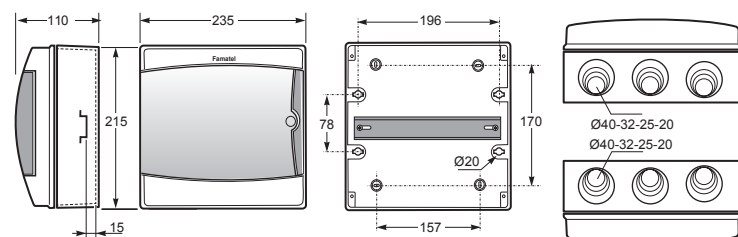

Dimensiones / Dimensions	
Altura / Height	215
Ancho / Width	235
Profundidad / Deep	110

Entradas / Entries

Superior / Top	3 x Ø20, Ø25, Ø32, Ø40
Inferior / Bottom	3 x Ø20, Ø25, Ø32, Ø40

Precintable / Sealable

Norma / Norm: **EN62208**



- Marco y base en ABS
- ventana transparente en PC
- Incluye tapones interiores para IP

- Frame and base in ABS
- Window transparent in PC
- Screw taps included for IP



Ref. Item **3908-T**

Armario / Enclosure - Ref. Item **3912-T**

1 7

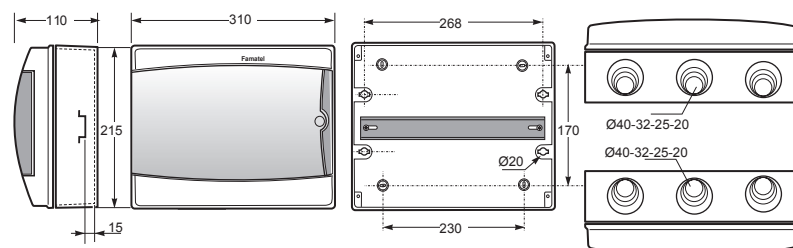

Dimensiones / Dimensions	
Altura / Height	215
Ancho / Width	310
Profundidad / Deep	110

Entradas / Entries

Superior / Top	3 x Ø20, Ø25, Ø32, Ø40
Inferior / Bottom	3 x Ø20, Ø25, Ø32, Ø40

Precintable / Sealable

Norma / Norm: **EN62208**



- Marco y base en ABS
- ventana transparente en PC
- Incluye tapones interiores para IP

- Frame and base in ABS
- Window transparent in PC
- Screw taps included for IP



Ref. Item **3912-T**

No incluye terminal de tierra y neutro, si se requieren terminales se los podemos suministrar montados en el armario o por separado, consultar páginas 212-213
It's no included earth-neutral terminal, if you want terminals we can provide to you already mounted in the enclosure or separately, please consult pages 212-213

ACQUA

Armario / Enclosure - Ref. Item **3926-T**

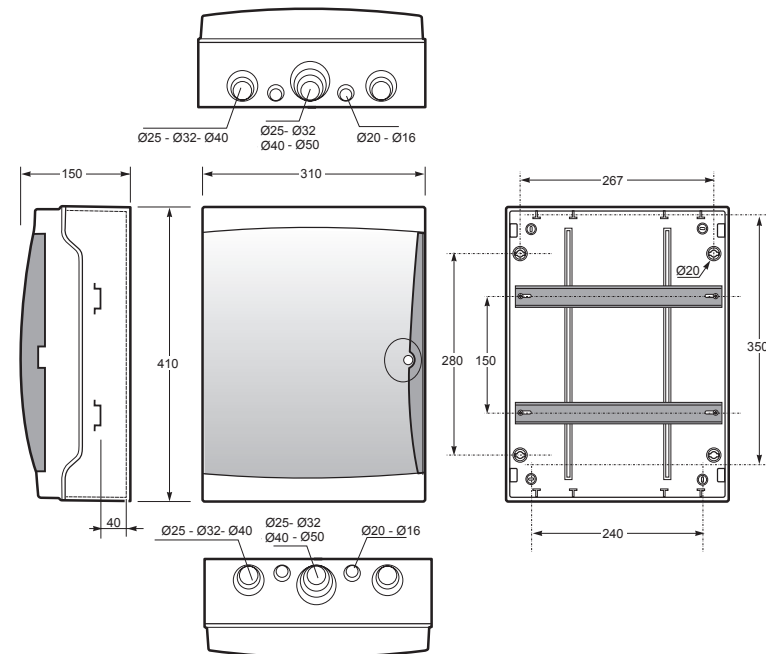

Dimensiones / Dimensions	
Altura / Height	410
Ancho / Width	310
Profundidad / Deep	150

Entradas / Entries	
Superior / Top	1 x Ø50, Ø40, Ø32, Ø25 2 x Ø40, Ø32, Ø25 2 x Ø20, Ø16
Inferior / Bottom	1 x Ø50, Ø40, Ø32, Ø25 2 x Ø40, Ø32, Ø25 2 x Ø20, Ø16

Precintable / Sealable

Norma / Norm: EN62208



- Marco y base en ABS
- ventana transparente en PC
- Incluye tapones interiores para IP

- Frame and base in ABS
- Window transparent in PC
- Screw taps included for IP



Ref. Item **3926-T**

Armario / Enclosure - Ref. Item **3942-T**

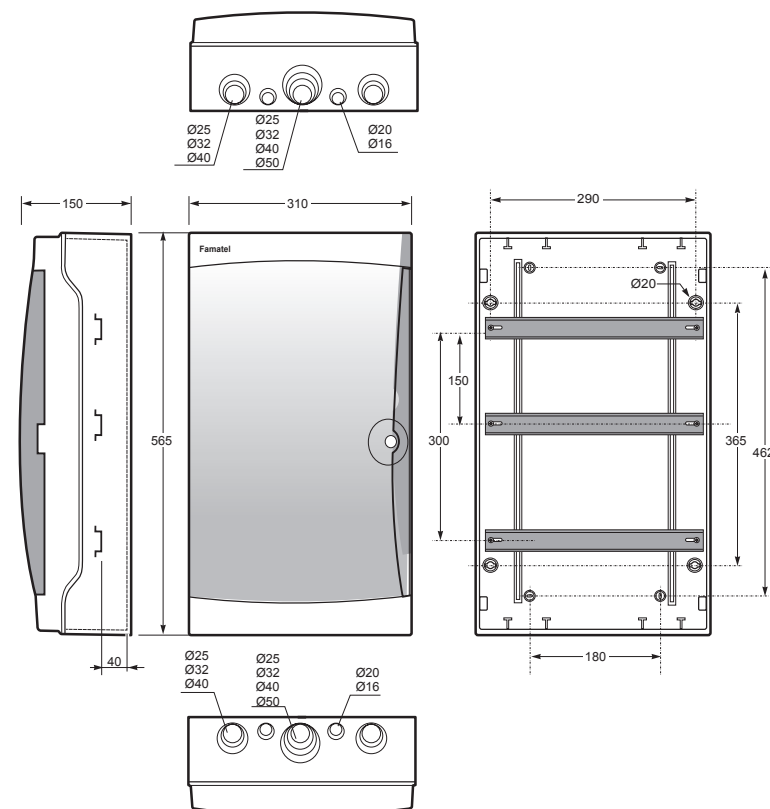

Dimensiones / Dimensions	
Altura / Height	565
Ancho / Width	310
Profundidad / Deep	150

Entradas / Entries	
Lateral	2 x Ø40, Ø32, Ø25 4 x Ø20, Ø16
Superior / Top	1 x Ø50, Ø40, Ø32, Ø25 2 x Ø40, Ø32, Ø25 2 x Ø20, Ø16
Inferior / Bottom	1 x Ø50, Ø40, Ø32, Ø25 2 x Ø40, Ø32, Ø25 2 x Ø20, Ø16

Precintable / Sealable

Norma / Norm: EN62208



- Marco y base en ABS
- ventana transparente en PC
- Incluye tapones interiores para IP

- Frame and base in ABS
- Window transparent in PC
- Screw taps included for IP



Ref. Item **3942-T**

No incluye terminal de tierra y neutro, si se requieren terminales se los podemos suministrar montados en el armario o por separado, consultar páginas 212-213
It's no included earth-neutral terminal, if you want terminals we can provide to you already mounted in the enclosure or separately, please consult pages 212-213

ACQUA

Armario / Enclosure - Ref. Item **3904**

1 ■ 17 ■

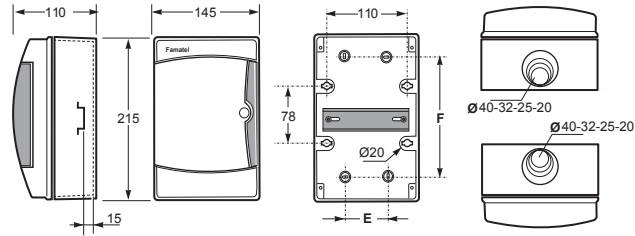

Dimensiones / Dimensions	
Altura / Height	215
Ancho / Width	145
Profundidad / Deep	110

Entradas / Entries	
Superior / Top	1 x Ø20, Ø25, Ø32, Ø40
Inferior / Bottom	1 x Ø20, Ø25, Ø32, Ø40

Precintable / Sealable

Norma / Norm: **EN62208**



- Marco y base en ABS
- ventana transparente en PC
- Incluye tapones interiores para IP

- Frame and base in ABS
- Window transparent in PC
- Screw taps included for IP



Ref. Item **3904**

Armario / Enclosure - Ref. Item **3908**

1 ■ 17 ■

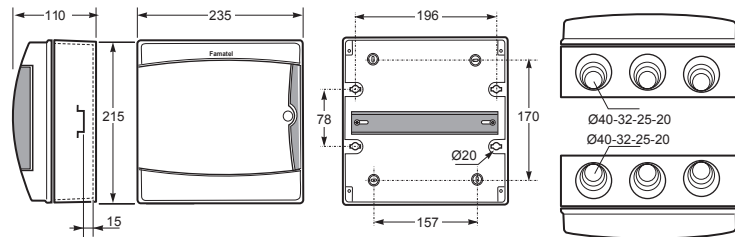

Dimensiones / Dimensions	
Altura / Height	215
Ancho / Width	235
Profundidad / Deep	110

Entradas / Entries	
Superior / Top	1 x Ø20, Ø25, Ø32, Ø40
Inferior / Bottom	1 x Ø20, Ø25, Ø32, Ø40

Precintable / Sealable

Norma / Norm: **EN62208**



- Marco y base en ABS
- ventana transparente en PC
- Incluye tapones interiores para IP

- Frame and base in ABS
- Window transparent in PC
- Screw taps included for IP



Ref. Item **3908**

Armario / Enclosure - Ref. Item **3912**

1 ■ 9 ■

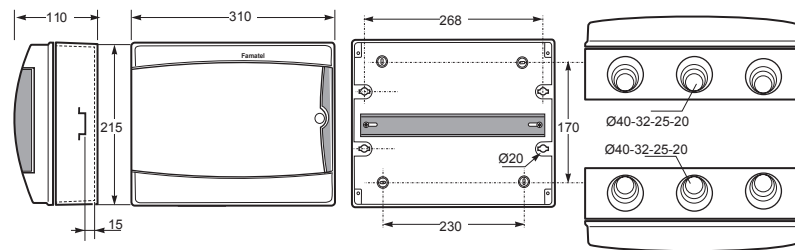

Dimensiones / Dimensions	
Altura / Height	215
Ancho / Width	145
Profundidad / Deep	110

Entradas / Entries	
Superior / Top	3 x Ø20, Ø25, Ø32, Ø40
Inferior / Bottom	3 x Ø20, Ø25, Ø32, Ø40

Precintable / Sealable

Norma / Norm: **EN62208**



- Marco y base en ABS
- ventana transparente en PC
- Incluye tapones interiores para IP

- Frame and base in ABS
- Window transparent in PC
- Screw taps included for IP



Ref. Item **3912**

No incluye terminal de tierra y neutro, si se requieren terminales se los podemos suministrar montados en el armario o por separado, consultar páginas 212-213
It's no included earth-neutral terminal, if you want terminals we can provide to you already mounted in the enclosure or separately, please consult pages 212-213

ACQUA

Armario / Enclosure - Ref. Item **3926**

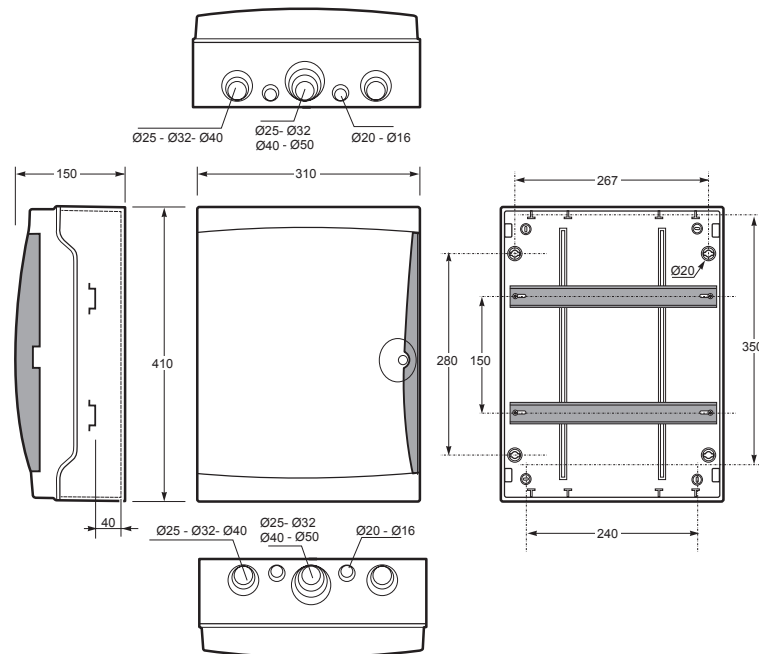

Dimensiones / Dimensions	
Altura / Height	410
Ancho / Width	310
Profundidad / Deep	150

Entradas / Entries	
Superior / Top	1 x Ø50, Ø40, Ø32, Ø25 2 x Ø40, Ø32, Ø25 2 x Ø20, Ø16
Inferior / Bottom	1 x Ø50, Ø40, Ø32, Ø25 2 x Ø40, Ø32, Ø25 2 x Ø20, Ø16

Precintable / Sealable

Norma / Norm: EN62208



- Marco y base en ABS
- ventana transparente en PC
- Incluye tapones interiores para IP

- Frame and base in ABS
- Window transparent in PC
- Screw taps included for IP



Ref. Item **3926**

Armario / Enclosure - Ref. Item **3942**

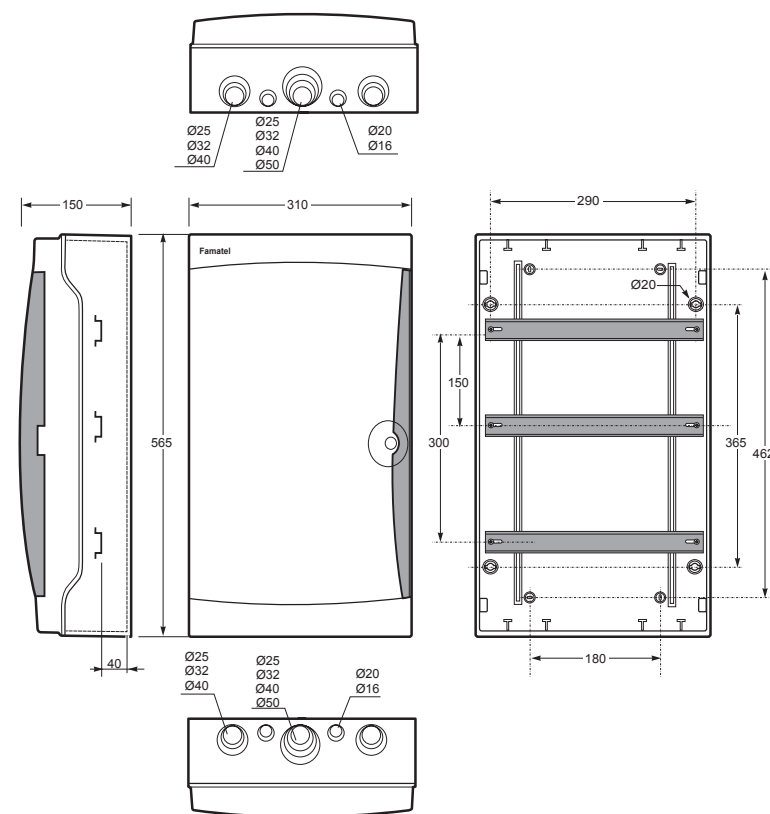

Dimensiones / Dimensions	
Altura / Height	565
Ancho / Width	310
Profundidad / Deep	150

Entradas / Entries	
Lateral	2 x Ø40, Ø32, Ø25 4 x Ø20, Ø16
Superior / Top	1 x Ø50, Ø40, Ø32, Ø25 2 x Ø40, Ø32, Ø25 2 x Ø20, Ø16
Inferior / Bottom	1 x Ø50, Ø40, Ø32, Ø25 2 x Ø40, Ø32, Ø25 2 x Ø20, Ø16

Precintable / Sealable

Norma / Norm: EN62208



- Marco y base en ABS
- ventana transparente en PC
- Incluye tapones interiores para IP

- Frame and base in ABS
- Window transparent in PC
- Screw taps included for IP



Ref. Item **3942**

No incluye terminal de tierra y neutro, si se requieren terminales se los podemos suministrar montados en el armario o por separado, consultar páginas 212-213
It's no included earth-neutral terminal, if you want terminals we can provide to you already mounted in the enclosure or separately, please consult pages 212-213

CONFIGURACIÓN ARMARIOS ACQUA / ACQUA ENCLOSURES CONFIGURATION

Si se requiere regleta de tierra y neutro, incluida y montada en la gama de armarios ACQUA, estos son los códigos y sus configuraciones:
If you require Earth and neutral terminal, included and mounted in the ACQUA enclosures, these are the codes to order and their configurations:

Ref. / Item	Configuración Configuration
3902-TTB	2 x RG-04
3902-TTB1	1 x RG-04



Ref. / Item	Configuración Configuration
3904-TTB	1 x SPTC-4



Ref. / Item	Configuración Configuration
3904-TB	1 x SPTC-4



Ref. / Item	Configuración Configuration
3908-TTB	1 x SPTA-12 + 1 x RG-12
3908-TTB1	1 x SPTA-12



Ref. / Item	Configuración Configuration
3908-TB	1 x SPTA-12 + 1 x RG-12



Ref. / Item	Configuración Configuration
3912-TTB	1 x SPTA-12 + 1 x RG-12



Ref. / Item	Configuración Configuration
3912-TB	1 x SPTA-12 + 1 x RG-12



Ref. / Item	Configuración Configuration
3926-TTB	2 x SPTA-12 + 2 x RG-12
3926-TTB1	1 x SPTA-12 + 1 x RG-12



Ref. / Item	Configuración Configuration
3926-TB	2 x SPTA-12 + 2 x RG-12
3926-TB1	1 x SPTA-12 + 1 x RG-12



Ref. / Item	Configuración Configuration
3942-TTB	3 x SPTA-12 + 3 x RG-12
3942-TTB1	1 x SPTA-12 + 1 x RG-12



Ref. / Item	Configuración Configuration
3942-TB	3 x SPTA-12 + 3 x RG-12
3942-TB1	1 x SPTA-12 + 1 x RG-12



ACCESORIOS Y TERMINALES / ACCESSORIES AND TERMINALS

Soporte regletas + regleta / Terminal bar support + Terminal bar - Ref. Item **SPTC-4** 1

- Soporte regletas de neutro y tierra para ref. 3904, 3904-T y serie Acqua Combi + 2 regletas RG-04 (2x16 mm² + 4x10 mm²).
- Neutral and earth terminal bar support for item 3904, 3904-T and Acqua Combi serie + 2 terminal bar RG-04 (2x16 mm² + 4x10 mm²).



Ref. Item
SPTC-4

Soporte regletas + regleta / Terminal bar support + Terminal bar - Ref. Item **SPTA-12** 1

- Soporte regleta de neutro y tierra para Acqua y Acqua Combi + 1 regleta RG-12 (2x16 mm² + 12x10 mm²).
- Neutral and earth terminal bar support for Acqua and Acqua Combi series + 1 terminal RG-12 (2x16 mm² + 12x10 mm²).



Ref. Item
SPTA-12

Regleta de neutro y tierra / Terminal bar - Ref. Item **RG-04** 1

- Regleta de neutro y tierra 2x16 mm² + 4x10 mm².
- Neutral and earth terminal bar 2x16 mm² + 4x10 mm².



Ref. Item
RG-04

Regleta de neutro y tierra / Terminal bar - Ref. Item **RG-12** 1

- Regleta de neutro y tierra 2x16 mm² + 12x10 mm².
- Neutral and earth terminal bar 2x16 mm² + 12x10 mm².



Ref. Item
RG-12

Cerradura metálica / Metal lock - Ref. Item **3900** 1

- Cerradura metálica serie Acqua, Acqua Plus y Acqua Combi.
- Metal lock for Acqua, Acqua Plus and Acqua Combi series.



Ref. Item
3900

8.8 CAJAS ESTANCAS
SEALED BOXES

Nuevo concepto de cajas estancas compuesto por más de 42 modelos para cubrir todas las necesidades de instalación. Fabricadas en material termoplástico de alta resistencia al impacto, protección de rayos ultravioletas y libres de halógenos. Estas cajas con un grado de protección IP55 garantizan una perfecta estanqueidad en cualquier tipo de instalación. El nuevo diseño de los conos permite asegurar el grado de estanqueidad entrando directamente con el cable sin necesidad de utilizar el tubo de instalación rígido.

A new concept of sealed boxes composed by 42 models covering all installation needs. They are made of thermoplastic material with high resistance to impact, protection against the UV and halogen free. These boxes with an IP55 protection degree are ready to be used in any kind of installation. The new design of the cones guarantees the IP55 degree with a direct cable entry without the need to use a rigid tube.



- Facilidad de rapidez e instalación
 - Libre de halógenos.
 - Alta resistencia al impacto
 - Tornillos cierre 1/4 vuelta
 - Sujeción tapa al abrir la caja
 - Nuevos conos que permiten la entrada directa del cable
- Easy and fast installation
 - Halogen free
 - High resistance to impact
 - 1/4 turn screw
 - Door hinges
 - New cones allowing the direct entry of the cable

Cono métrico
Metric cones

Precintable
Sealable

Sujeción puerta
Door hinge

Tornillo 1/4 vuelta
1/4 turn screw

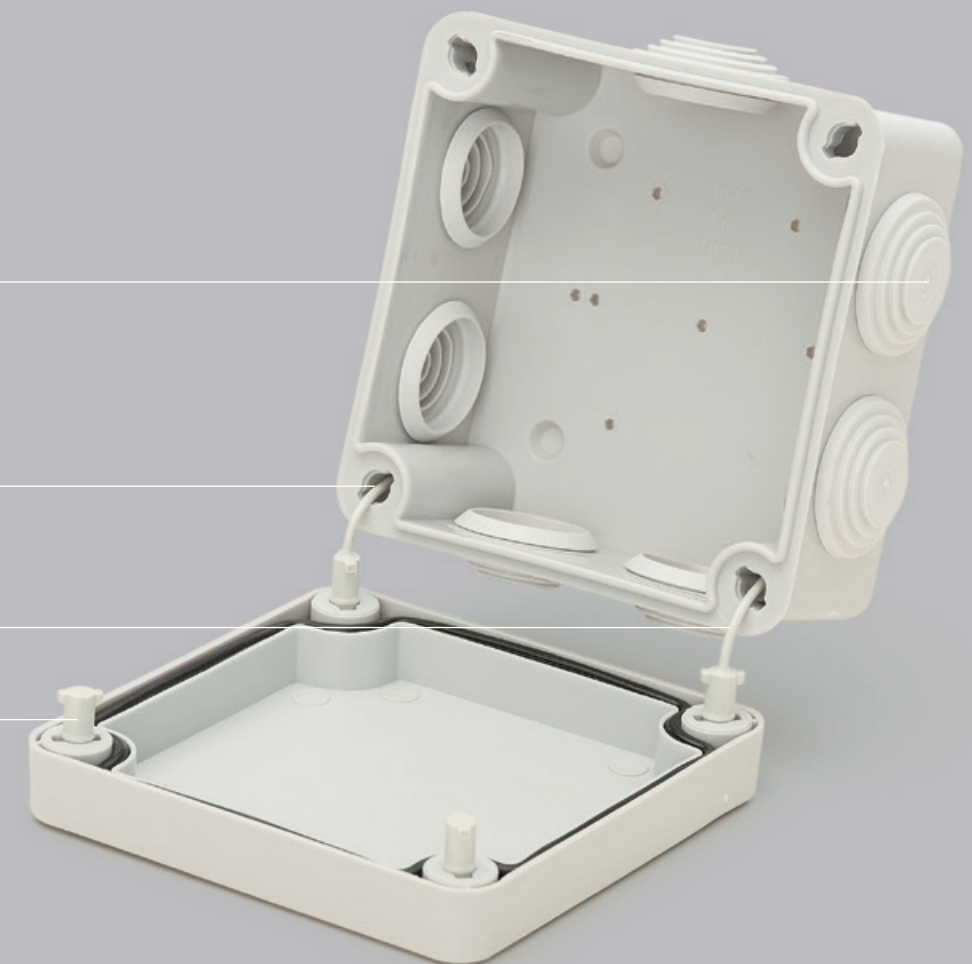



Nuevos conos especiales de entrada directa del cable
New cones allowing the direct entry of the cables



Sujeción de la tapa al abrir la caja
Door hinges



Tornillos de cierre rápidos 1/4 vuelta
1/4 turn screw



Nuevo diseño del cono pasacable que asegura una perfecta estanqueidad
New cones guaranteeing the IP55 protection



Apertura con un solo click
Click opening



Posibilidad de fijación con bridas
Possibility of fixation through cable ties

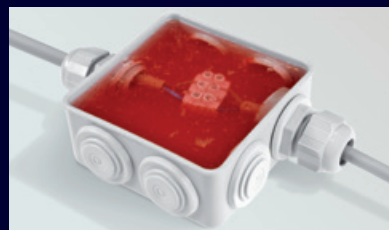

En algunas ocasiones podemos tener que hacer frente a situaciones de extrema humedad, posibilidad de filtraciones de agua o líquidos, etc. Gracias al gel aislante de la gama Famatel EasyLife, podemos asegurar la impermeabilidad al 100% en cualquier circunstancia.

In some circumstances we need to face situations of extreme humidity, water filtration or liquids. Through the isolating gel of Famatel EasyLife range we guarantee the impermeability 100% in any situation.



Piscinas
Swimming pool



Bodegas
Wine cellar



Campos de cultivo
Farmland

SERIE MINIBOX

MINIBOS SERIES

Pg. 218



CAJAS ESTANCAS CON CONOS

SEALED BOXES WITH CONES

Pg. 220



CAJAS ESTANCAS SIN CONOS

SEALED BOXES WITHOUT CONES

Pg. 228



CAJAS ESTANCAS TRANSPARENTES

TRANSPARENT SEALED BOXES

Pg. 232

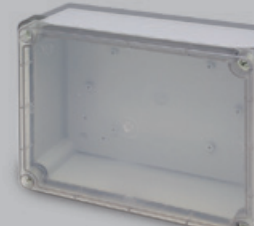

CAJAS ESTANCAS IP65

IP65 SEALED BOXES

Pg. 234



CAJAS ESTANCAS ESPECIALES

SPECIAL SEALED BOXES

Pg. 238



CAJAS ESTANCAS PRECABLEADAS

PRE-WIRED SEALED BOXES

Pg. 240



ACCESORIOS

ACCESORIES

Pg. 242



CAJAS MINIBOX IP55 / MINIBOX BOXES IP55

Minibox IP55 / Minibox IP55 - Ref. Item **3050**

8 456

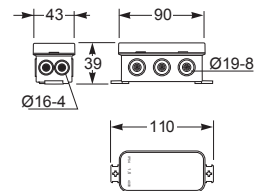

Dimensiones exteriores / External dimensions	
Altura / Height	43
Ancho / Width	90
Profundidad / Deep	39

Entradas / Entries	
Superior / Top	3 x Ø 8-19
Inferior / Bottom	3 x Ø 8-19
Lado / Side	4 x Ø 4-16

Norma / Norm:	EN60670-22
---------------	------------



- Tapa y base en PP/PS
- Sistema de sujeción exterior
- Entradas pretroqueladas
- Cover and base in PP/PS
- External subjection system
- Knock-outs



BOX
MINI

Ref. Item
3050

Minibox IP55 / Minibox IP55 - Ref. Item **3051**

8 280

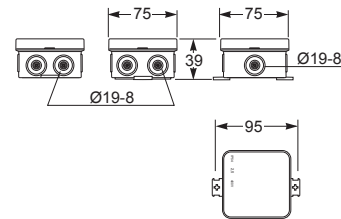

Dimensiones exteriores / External dimensions	
Altura / Height	75
Ancho / Width	75
Profundidad / Deep	39

Entradas / Entries	
Superior / Top	2 x Ø 8-19
Inferior / Bottom	1 x Ø 8-19
Lado / Side	4 x Ø 4-19

Norma / Norm:	EN60670-22
---------------	------------



- Tapa y base en PP/PS
- Sistema de sujeción exterior
- Entradas pretroqueladas
- Cover and base in PP/PS
- External subjection system
- Knock-outs



BOX
MINI

Ref. Item
3051

Minibox IP55 / Minibox IP55 - Ref. Item **3052**

8 224

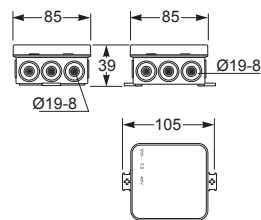

Dimensiones exteriores / External dimensions	
Altura / Height	85
Ancho / Width	85
Profundidad / Deep	39

Entradas / Entries	
Superior / Top	3 x Ø 8-19
Inferior / Bottom	3 x Ø 8-19
Lado / Side	6 x Ø 8-19

Norma / Norm:	EN60670-22
---------------	------------



- Tapa y base en PP/PS
- Sistema de sujeción exterior
- Entradas pretroqueladas
- Cover and base in PP/PS
- External subjection system
- Knock-outs



BOX
MINI

Ref. Item
3052

Minibox direct / Minibox direct - Ref. Item **3056 / 3059**

6 90

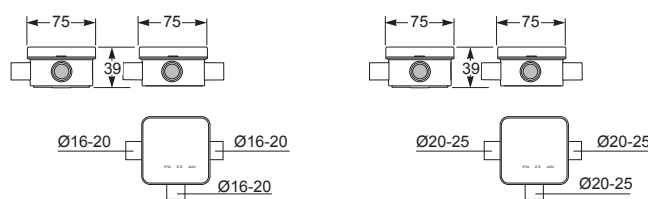

Ref. / Item: **3056**

Ref. / Item: **3059**

Dimensiones exteriores / External dimensions	
Altura / Height	75
Ancho / Width	75
Profundidad / Deep	39

Entradas / Entries		3056	3059
Superior / Top		--	--
Inferior / Bottom		1 x Ø 16/20	1 x Ø 20/25
Lado / Side		2 x Ø 16/20	2 x Ø 20/25

Norma / Norm:	EN60670-22
---------------	------------



- Tapa y base en PP/PS
- Sistema de sujeción exterior
- Entradas para inserción directa de tubos multidímetro
- Cover and base in PP/PS
- External subjection system
- Inputs for direct insertion of multidiameter tubes



BOX
MINI
direct

Ref. Item
3056 / 3059

CAJAS ESTANCAS CON CONOS IP55/IP20 / SEALED BOXES WITH CONES IP55/IP20

Caja con conos IP55 / Box with cones IP55 - Ref. Item **3001** 12 144

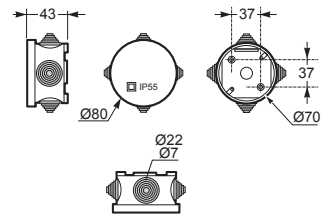

Dimensiones interiores / Internal dimensions	
Altura / Height	35
Ancho / Width	Ø 70
Entradas / Entries	
Lado / Side	4 conos/cones x Ø 20
Norma / Norm: EN60670-22	



- Tapa y base en ABS
- Cierre tapa a presión
- Conos para entrada directa de cable
- Cover and base in ABS
- Press cover
- Cones allowing the direct entry of the cables



Ref. Item **3001**

Caja portalámparas IP20 / Box with lamp-holder IP20 - Ref. Item **3005** 6 36

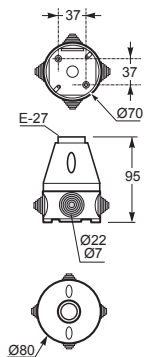

Dimensiones interiores / Internal dimensions	
Altura / Height	95
Ancho / Width	Ø 70
Entradas / Entries	
Lado / Side	4 conos/cones x Ø 20
Norma / Norm: EN60670-22 / EN60238	



- Tapa y base en ABS
- Cierre tapa por tornillos
- Conos para entrada directa de cable
- Portalámparas porcelana E-27
- Cover and base in ABS
- Press cover
- Cones allowing the direct entry of the cables
- Ceramic lampholder E-27



Ref. Item **3005**

Caja portalámparas IP20 / Box with lamp-holder IP20 - Ref. Item **3005B** 6 36

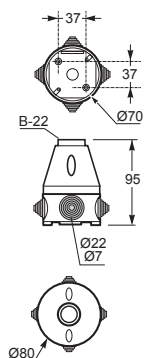

Dimensiones interiores / Internal dimensions	
Altura / Height	95
Ancho / Width	Ø 70
Entradas / Entries	
Lado / Side	4 conos/cones x Ø 20
Norma / Norm: EN60670-22 / EN60238	



- Tapa y base en ABS
- Cierre tapa por tornillos
- Conos para entrada directa de cable
- Portalámparas porcelana B-22
- Cover and base in ABS
- Press cover
- Cones allowing the direct entry of the cables
- Ceramic lampholder B-22



Ref. Item **3005B**

Caja con conos IP55 / Box with cones IP55 - Ref. Item **3002** 8 120

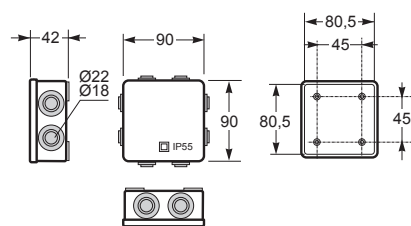

Dimensiones interiores / Internal dimensions	
Altura / Height	80
Ancho / Width	80
Profundidad / Deep	36
Entradas / Entries	
Superior / Top	2 conos/cones x Ø 20
Inferior / Bottom	2 conos/cones x Ø 20
Lado / Side	4 conos/cones x Ø 20
Norma / Norm: EN60670-22	



- Tapa y base en ABS
- Cierre tapa a presión
- Conos para entrada directa de cable
- Cover and base in ABS
- Press cover
- Cones allowing the direct entry of the cables



Ref. Item **3002**

CAJAS ESTANCAS CON CONOS IP68/IP55 / SEALED BOXES WITH CONES IP68/IP55

Kit IP68 / Kit IP68 - Ref. Item **3002-GL**

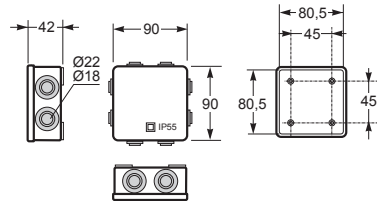

Dimensiones interiores / Internal dimensions	
Altura / Height	80
Ancho / Width	80
Profundidad / Deep	36

Entradas / Entries	
Superior / Top	2 conos/conos Ø 8-19
Inferior / Bottom	2 conos/conos Ø 8-19
Lado / Side	4 conos/conos Ø 8-19

Norma / Norm:	EN60670-22
---------------	------------



- El kit incluye:
- Caja estanca ref. 3002 80x80x36
 - 2 prensaestopas aislantes M20
 - Gel aislante color rojo
- The kit includes:
- Sealed box item 3002 80x80x36
 - 2 isolation cable glands M20
 - Isolation



Ref. Item **3002-GL**

Caja con conos IP55 / Box with cones IP55 - Ref. Item **3003**

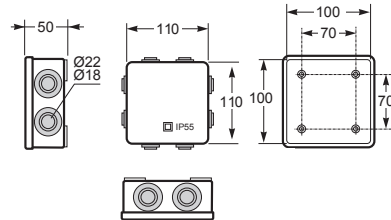

Dimensiones interiores / Internal dimensions	
Altura / Height	100
Ancho / Width	100
Profundidad / Deep	45

Entradas / Entries	
Superior / Top	2 conos/conos Ø 20
Inferior / Bottom	1 conos/conos Ø 20
Lado / Side	4 conos/conos Ø 20

Norma / Norm:	EN60670-22
---------------	------------



- Tapa y base en ABS
 - Cierre tapa a presión
 - Conos para entrada directa de cable
- Cover and base in ABS
 - Press cover
 - Cones allowing the direct entry of the cables



Ref. Item **3003**

Caja con conos IP55 / Box with cones IP55 - Ref. Item **3011**

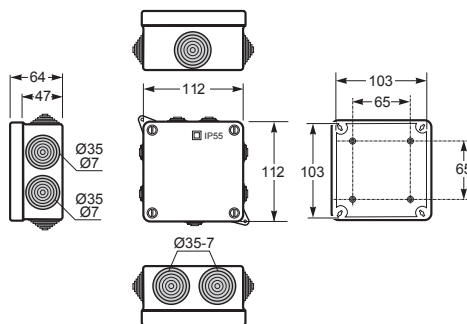

Dimensiones interiores / Internal dimensions	
Altura / Height	100
Ancho / Width	100
Profundidad / Deep	55

Entradas / Entries	
Superior / Top	2 conos/conos Ø 25
Inferior / Bottom	1 conos/conos Ø 25
Lado / Side	4 conos/conos Ø 25

Norma / Norm:	EN60670-22
---------------	------------



- Tapa y base en ABS
 - Sujeción tapa al abrir la tapa
 - Tornillos 1/4 de vuelta
 - Conos para entrada directa de cable
- Cover and base in ABS
 - Door hinges
 - 1/4 turn screw
 - Cones allowing the direct entry of the cables



Ref. Item **3011**

Caja con conos IP55 / Box with cones IP55 - Ref. Item **3031**

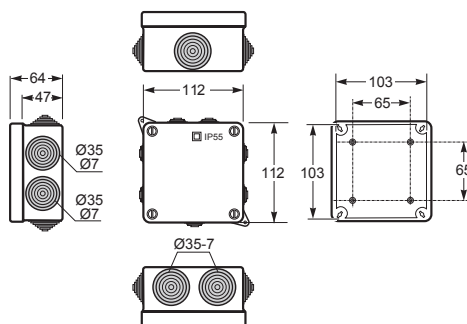

Dimensiones interiores / Internal dimensions	
Altura / Height	103
Ancho / Width	103
Profundidad / Deep	45

Entradas / Entries	
Superior / Top	2 conos/conos Ø 25
Inferior / Bottom	1 conos/conos Ø 25
Lado / Side	4 conos/conos Ø 25

Norma / Norm:	EN60670-22
---------------	------------



- Tapa y base en ABS
 - Sujeción tapa al abrir la tapa
 - Tornillos 1/4 de vuelta
 - Conos para entrada directa de cable
 - Libre de halógenos excepto conos
- Cover and base in ABS
 - Door hinges
 - 1/4 turn screw
 - Cones allowing the direct entry of the cables
 - Halogen free except cones



Ref. Item **3031**

CAJAS ESTANCAS CON CONOS IP55 / SEALED BOXES WITH CONES IP55

Caja con conos IP55 / Box with cones IP55 - Ref. Item 3012 4 72

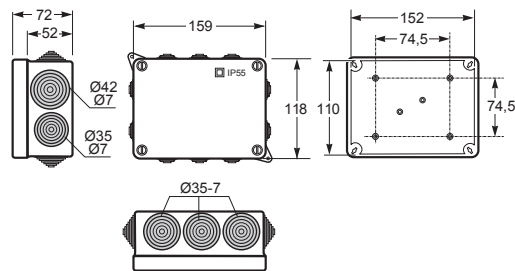

Dimensiones interiores / Internal dimensions	
Altura / Height	110
Ancho / Width	152
Profundidad / Deep	63
Entradas / Entries	
Superior / Top	3 conos/cones Ø 25
Inferior / Bottom	3 conos/cones Ø 25
Lado / Side	2 conos/cones Ø 25 + 2 conos/cones Ø 32
Norma / Norm: EN60670-22	



- Tapa y base en ABS
- Sujeción tapa al abrir la tapa
- Tornillos 1/4 de vuelta
- Conos para entrada directa de cable
- Cover and base in ABS
- Door hinges
- 1/4 turn screw
- Cones allowing the direct entry of the cables



Ref. Item 3012

Caja con conos IP55 / Box with cones IP55 - Ref. Item 3032 4 72

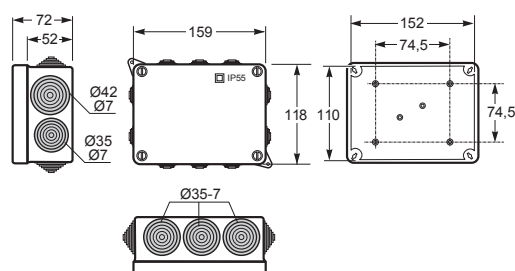

Dimensiones interiores / Internal dimensions	
Altura / Height	110
Ancho / Width	152
Profundidad / Deep	63
Entradas / Entries	
Superior / Top	3 conos/cones Ø 25
Inferior / Bottom	3 conos/cones Ø 25
Lado / Side	2 conos/cones Ø 25 + 2 conos/cones Ø 32
Norma / Norm: EN60670-22	



- Tapa y base en ABS
- Sujeción tapa al abrir la tapa
- Tornillos 1/4 de vuelta
- Conos para entrada directa de cable
- Libre de alógenos excepto conos
- Cover and base in ABS
- Door hinges
- 1/4 turn screw
- Cones allowing the direct entry of the cables
- Halogen free except cones



Ref. Item 3032

Caja con conos IP55 / Box with cones IP55 - Ref. Item 3013 1 42

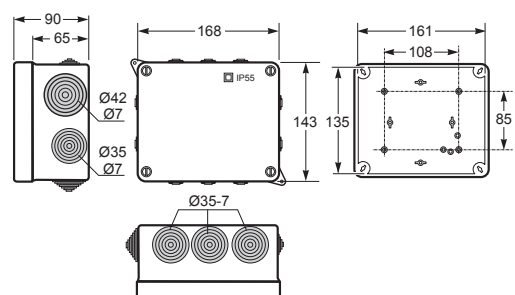

Dimensiones interiores / Internal dimensions	
Altura / Height	135
Ancho / Width	161
Profundidad / Deep	83
Entradas / Entries	
Superior / Top	3 conos/cones Ø 32
Inferior / Bottom	3 conos/cones Ø 32
Lado / Side	2 conos/cones Ø 32 + 2 conos/cones Ø 40
Norma / Norm: EN60670-22	



- Tapa y base en ABS
- Sujeción tapa al abrir la tapa
- Tornillos 1/4 de vuelta
- Conos para entrada directa de cable
- Cover and base in ABS
- Door hinges
- 1/4 turn screw
- Cones allowing the direct entry of the cables



Ref. Item 3013

Caja con conos IP55 / Box with cones IP55 - Ref. Item 3033 1 42

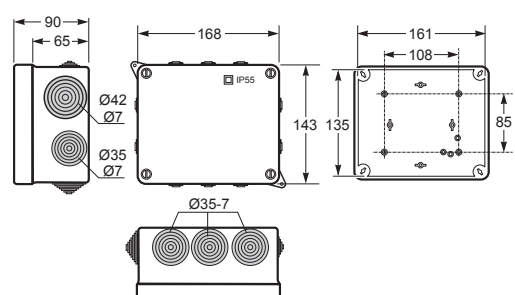

Dimensiones interiores / Internal dimensions	
Altura / Height	135
Ancho / Width	161
Profundidad / Deep	83
Entradas / Entries	
Superior / Top	3 conos/cones Ø 32
Inferior / Bottom	3 conos/cones Ø 32
Lado / Side	2 conos/cones Ø 32 + 2 conos/cones Ø 40
Norma / Norm: EN60670-22	



- Tapa y base en ABS
- Sujeción tapa al abrir la tapa
- Tornillos 1/4 de vuelta
- Conos para entrada directa de cable
- Libre de alógenos excepto conos
- Cover and base in ABS
- Door hinges
- 1/4 turn screw
- Cones allowing the direct entry of the cables
- Halogen free except cones



Ref. Item 3033

CAJAS ESTANCAS CON CONOS IP55 / SEALED BOXES WITH CONES IP55

Caja con conos IP55 / Box with cones IP55 - Ref. Item 3014 1 28

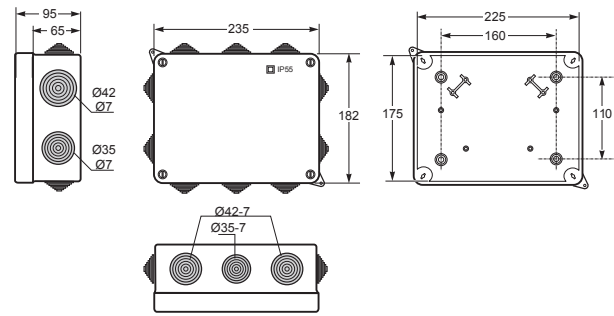

Dimensiones interiores / Internal dimensions	
Altura / Height	175
Ancho / Width	225
Profundidad / Deep	85

Entradas / Entries	
Superior / Top	2 conos/cones Ø 40 + 1 Ø 32
Inferior / Bottom	2 conos/cones Ø 40 + 1 Ø 32
Lado / Side	2 conos/cones Ø 32 + 2 conos/cones Ø 40

Norma / Norm:	EN60670-22
---------------	------------



- Tapa y base en ABS
 - Sujeción tapa al abrir la tapa
 - Tornillos 1/4 de vuelta
 - Conos para entrada directa de cable
-
- Cover and base in ABS
 - Door hinges
 - 1/4 turn screw
 - Cones allowing the direct entry of the cables



Ref. Item
3014

Caja con conos IP55 / Box with cones IP55 - Ref. Item 3034 1 28

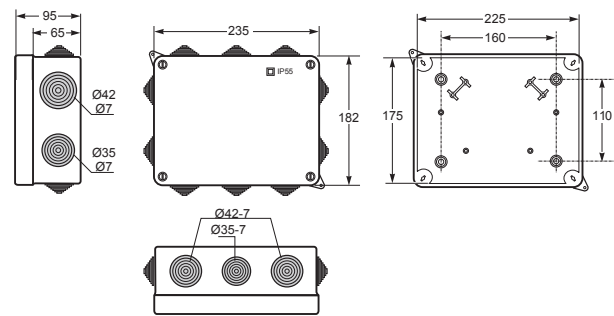

Dimensiones interiores / Internal dimensions	
Altura / Height	175
Ancho / Width	225
Profundidad / Deep	85

Entradas / Entries	
Superior / Top	2 conos/cones Ø 40 + 1 Ø 32
Inferior / Bottom	2 conos/cones Ø 40 + 1 Ø 32
Lado / Side	2 conos/cones Ø 32 + 2 conos/cones Ø 40

Norma / Norm:	EN60670-22
---------------	------------



- Tapa y base en ABS
 - Sujeción tapa al abrir la tapa
 - Tornillos 1/4 de vuelta
 - Conos para entrada directa de cable
 - * Libre de alógenos excepto conos
-
- Cover and base in ABS
 - Door hinges
 - 1/4 turn screw
 - Cones allowing the direct entry of the cables
 - * Halogen free except cones



Ref. Item
3034

Caja con conos IP55 / Box with cones IP55 - Ref. Item 3015 1 10

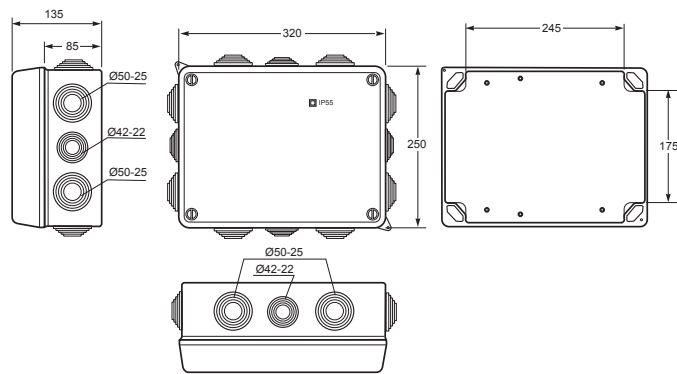

Dimensiones interiores / Internal dimensions	
Altura / Height	240
Ancho / Width	310
Profundidad / Deep	125

Entradas / Entries	
Superior / Top	2 conos/cones Ø 50 + 1 Ø 40
Inferior / Bottom	2 conos/cones Ø 50 + 1 Ø 40
Lado / Side	4 conos/cones Ø 50 + 2 Ø 40

Norma / Norm:	EN60670-22
---------------	------------



- Tapa y base en ABS
 - Sujeción tapa al abrir la tapa
 - Tornillos 1/4 de vuelta
 - Conos para entrada directa de cable
-
- Cover and base in ABS
 - Door hinges
 - 1/4 turn screw
 - Cones allowing the direct entry of the cables



Ref. Item
3015

Caja con conos IP55 / Box with cones IP55 - Ref. Item 3035 1 10

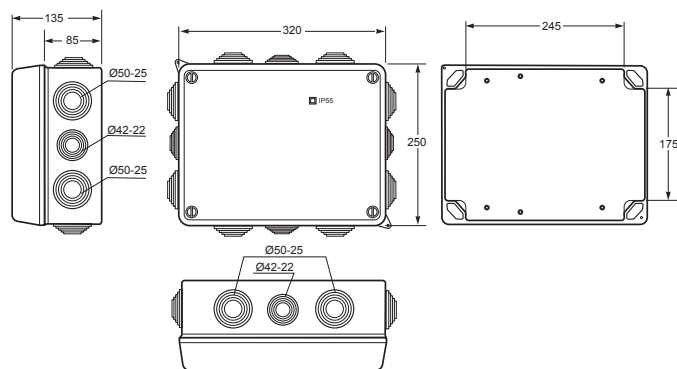

Dimensiones interiores / Internal dimensions	
Altura / Height	240
Ancho / Width	310
Profundidad / Deep	125

Entradas / Entries	
Superior / Top	2 conos/cones Ø 50 + 1 Ø 40
Inferior / Bottom	2 conos/cones Ø 50 + 1 Ø 40
Lado / Side	4 conos/cones Ø 50 + 2 Ø 40

Norma / Norm:	EN60670-22
---------------	------------



- Tapa y base en ABS
 - Sujeción tapa al abrir la tapa
 - Tornillos 1/4 de vuelta
 - Conos para entrada directa de cable
 - * Libre de alógenos excepto conos
-
- Cover and base in ABS
 - Door hinges
 - 1/4 turn screw
 - Cones allowing the direct entry of the cables
 - * Halogen free except cones



Ref. Item
3035

CAJAS CIEGAS IP55 / BLIND BOXES IP55

Caja ciega IP55 / Blind box IP55 - Ref. Item **3062**

6 144

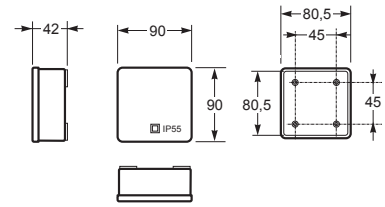

Dimensiones interiores / Internal dimensions	
Altura / Height	80
Ancho / Width	80
Profundidad / Deep	36

Norma / Norm: EN60670-22



- Tapa y base en ABS
- Cierre tapa a presión
- Cover and base in ABS
- Press cover



Ref. Item **3062**

Caja ciega IP55 / Blind box IP55 - Ref. Item **3063**

5 180

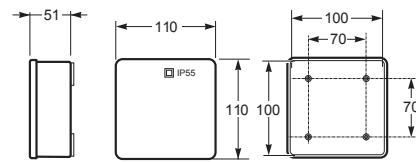

Dimensiones interiores / Internal dimensions	
Altura / Height	100
Ancho / Width	100
Profundidad / Deep	45

Norma / Norm: EN60670-22



- Tapa y base en ABS
- Cierre tapa a presión
- Cover and base in ABS
- Press cover



Ref. Item **3063**

Caja ciega IP55 / Blind box IP55 - Ref. Item **3071**

5 125

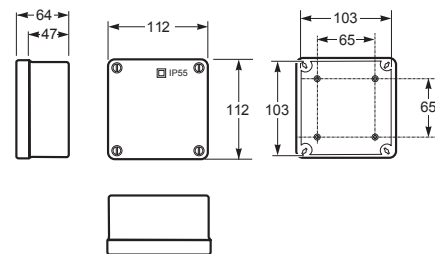

Dimensiones interiores / Internal dimensions	
Altura / Height	100
Ancho / Width	100
Profundidad / Deep	55

Norma / Norm: EN60670-22



- Tapa y base en ABS
- Sujeción tapa al abrir la tapa
- Tornillos 1/4 de vuelta
- Cover and base in ABS
- Door hinges
- 1/4 turn screw



Ref. Item **3071**

Caja ciega IP55 / Blind box IP55 - Ref. Item **3072**

4 80

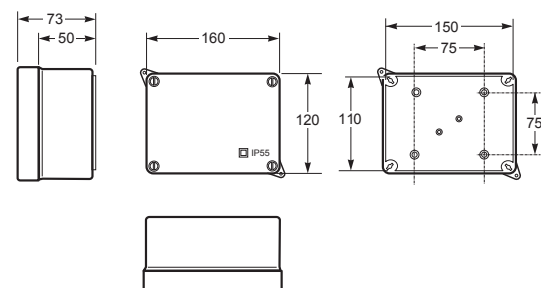

Dimensiones interiores / Internal dimensions	
Altura / Height	110
Ancho / Width	150
Profundidad / Deep	63

Norma / Norm: EN60670-22



- Tapa y base en ABS
- Sujeción tapa al abrir la tapa
- Tornillos 1/4 de vuelta
- Cover and base in ABS
- Door hinges
- 1/4 turn screw



Ref. Item **3072**

CAJAS CIEGAS IP55 / BLIND BOXES IP55

Caja ciega IP55 / Blind box IP55 - Ref. Item **3073**

1 48

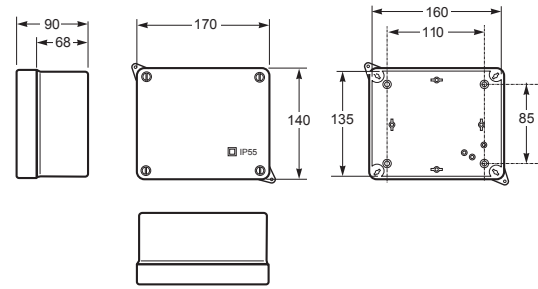

Dimensiones interiores / Internal dimensions	
Altura / Height	135
Ancho / Width	160
Profundidad / Deep	83

Norma / Norm: EN60670-22



- Tapa y base en ABS
- Sujeción tapa al abrir la tapa
- Tornillos 1/4 de vuelta
- Cover and base in ABS
- Door hinges
- 1/4 turn screw



Ref. Item **3073**

Caja ciega IP55 / Blind box IP55 - Ref. Item **3074**

1 28

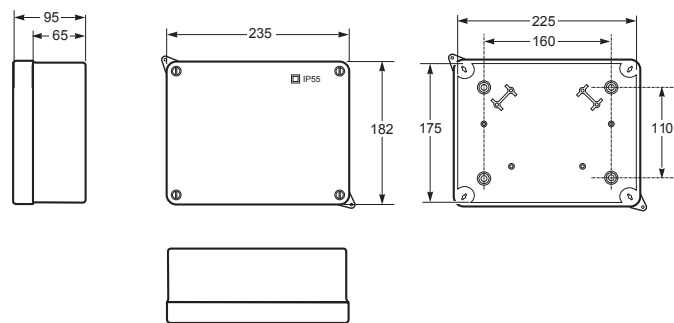

Dimensiones interiores / Internal dimensions	
Altura / Height	175
Ancho / Width	225
Profundidad / Deep	85

Norma / Norm: EN60670-22



- Tapa y base en ABS
- Sujeción tapa al abrir la tapa
- Tornillos 1/4 de vuelta
- Cover and base in ABS
- Door hinges
- 1/4 turn screw



Ref. Item **3074**

Caja ciega IP55 / Blind box IP55 - Ref. Item **3075**

1 10

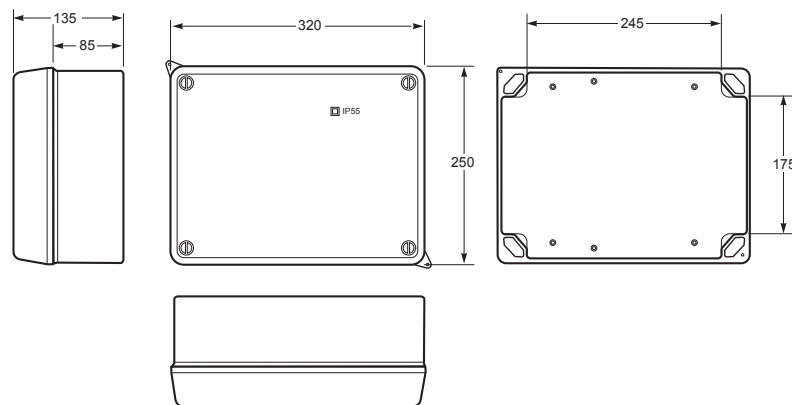

Dimensiones interiores / Internal dimensions	
Altura / Height	240
Ancho / Width	310
Profundidad / Deep	125

Norma / Norm: EN60670-22



- Tapa y base en ABS
- Sujeción tapa al abrir la tapa
- Tornillos 1/4 de vuelta
- Cover and base in ABS
- Door hinges
- 1/4 turn screw



Ref. Item **3075**

CAJAS TRANSPARENTES IP55 / BLIND TRANSPARENTS IP55

Caja ciega IP55 / Blind box IP55 - Ref. Item **3042**

4 80

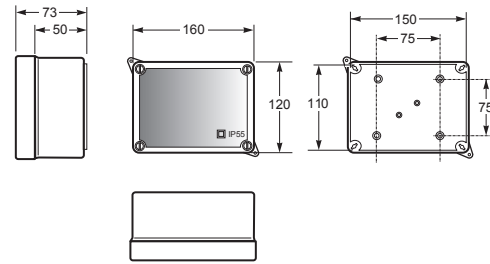

Dimensiones interiores / Internal dimensions	
Altura / Height	110
Ancho / Width	150
Profundidad / Deep	63

Norma / Norm: EN60670-22



- Tapa y base en ABS
- Sujeción tapa al abrir la tapa
- Tornillos 1/4 de vuelta
- Cover and base in ABS
- Door hinges
- 1/4 turn screw



Ref. Item **3042**

Caja ciega IP55 / Blind box IP55 - Ref. Item **3043**

2 48

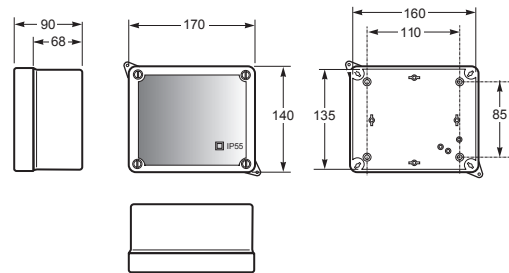

Dimensiones interiores / Internal dimensions	
Altura / Height	135
Ancho / Width	160
Profundidad / Deep	83

Norma / Norm: EN60670-22



- Tapa y base en ABS
- Sujeción tapa al abrir la tapa
- Tornillos 1/4 de vuelta
- Cover and base in ABS
- Door hinges
- 1/4 turn screw

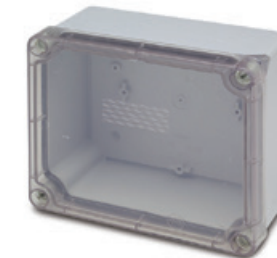

Ref. Item **3043**

Caja ciega IP55 / Blind box IP55 - Ref. Item **3044**

1 28

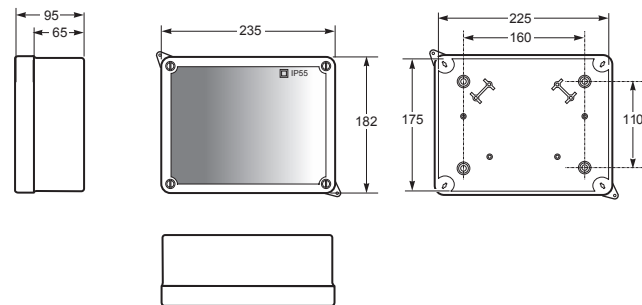

Dimensiones interiores / Internal dimensions	
Altura / Height	175
Ancho / Width	225
Profundidad / Deep	85

Norma / Norm: EN60670-22



- Tapa y base en ABS
- Sujeción tapa al abrir la tapa
- Tornillos 1/4 de vuelta
- Cover and base in ABS
- Door hinges
- 1/4 turn screw



Ref. Item **3044**

Caja ciega IP55 / Blind box IP55 - Ref. Item **3045**

1 10

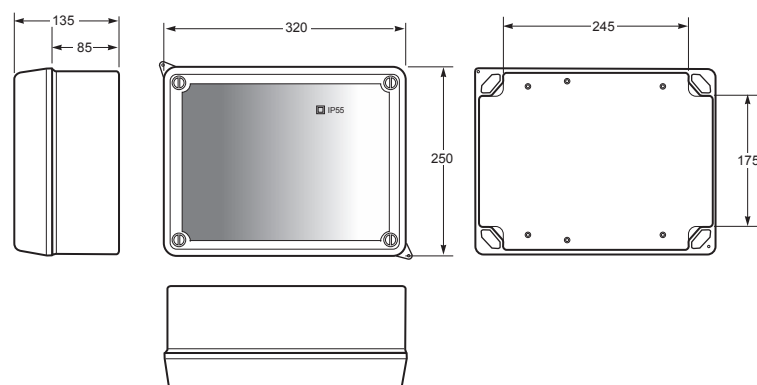

Dimensiones interiores / Internal dimensions	
Altura / Height	240
Ancho / Width	310
Profundidad / Deep	125

Norma / Norm: EN60670-22



- Tapa y base en ABS
- Sujeción tapa al abrir la tapa
- Tornillos 1/4 de vuelta
- Cover and base in ABS
- Door hinges
- 1/4 turn screw



Ref. Item **3045**

CAJAS ESTANCAS IP65 / SEALED BOXES IP65

Caja ciega IP65 / Blind box IP65 - Ref. Item **3955**

1 80

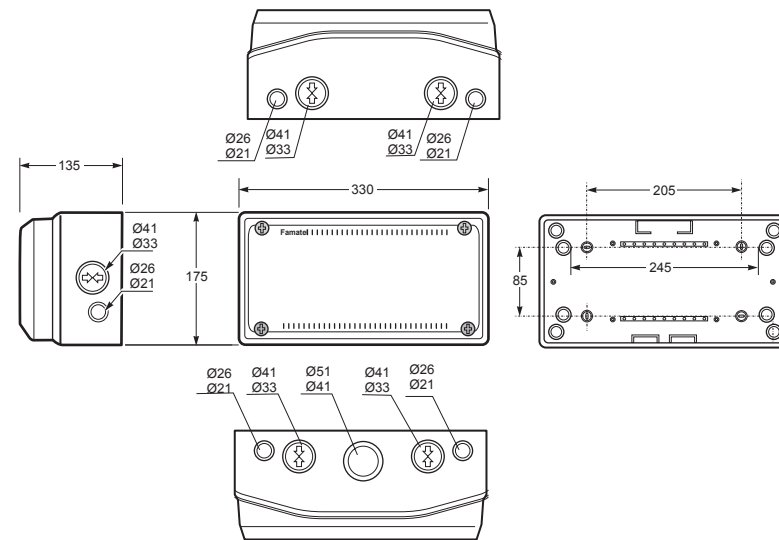

Dimensiones exteriores / External dimensions	
Altura / Height	175
Ancho / Width	330
Profundidad / Deep	135

Entradas / Entries	
Superior / Top	2 x Ø 32-40 + 2 x Ø 20-25 + 1 x Ø 40-50
Inferior / Bottom	2 x Ø 32-40 + 2 x Ø 20-25
Lado / Side	2 x Ø 32-40 + 2 x Ø 20-25

Norma / Norm: EN60670-22	
--------------------------	--



- Tapa y base en ABS
- Sujeción tapa al abrir la tapa
- Entradas pretroqueladas para entrada tubo métrica
- Enlazables

- Cover and base in ABS
- Door hinges
- Knock outs
- Linkables



Ref. Item
3955

Caja ciega IP65 / Blind box IP65 - Ref. Item **3956**

1 4

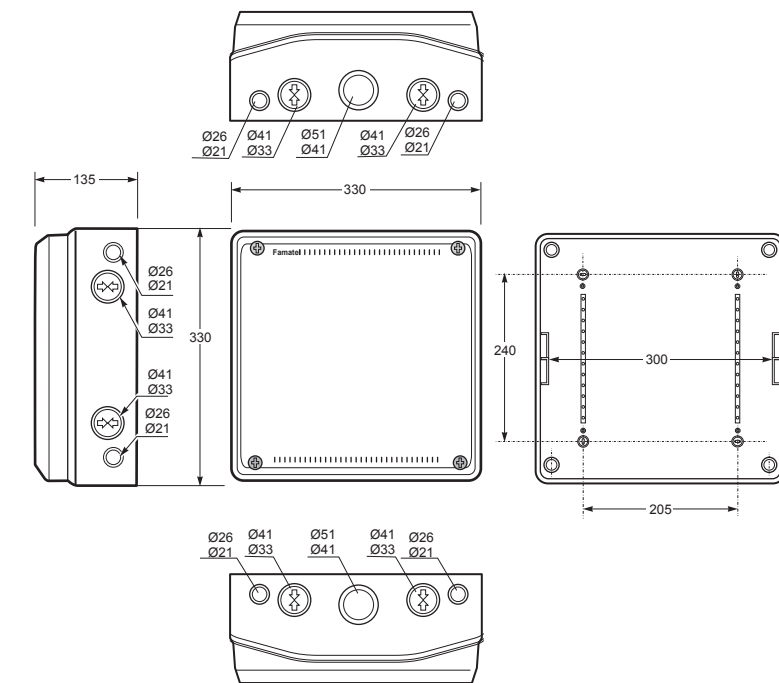

Dimensiones exteriores / External dimensions	
Altura / Height	330
Ancho / Width	330
Profundidad / Deep	135

Entradas / Entries	
Superior / Top	2 x Ø 32-40 + 2 x Ø 20-25 + 1 x Ø 40-50
Inferior / Bottom	2 x Ø 32-40 + 2 x Ø 20-25 + 1 x Ø 40-50
Lado / Side	4 x Ø 32-40 + 4 x Ø 20-25

Norma / Norm: EN60670-22	
--------------------------	--



- Tapa y base en ABS
- Sujeción tapa al abrir la tapa
- Entradas pretroqueladas para entrada tubo métrica
- Enlazables

- Cover and base in ABS
- Door hinges
- Knock outs
- Linkables



Ref. Item
3956

CAJAS ESTANCAS IP65 / SEALED BOXES IP65

Caja ciega IP65 / Blind box IP65 - Ref. Item **3953**

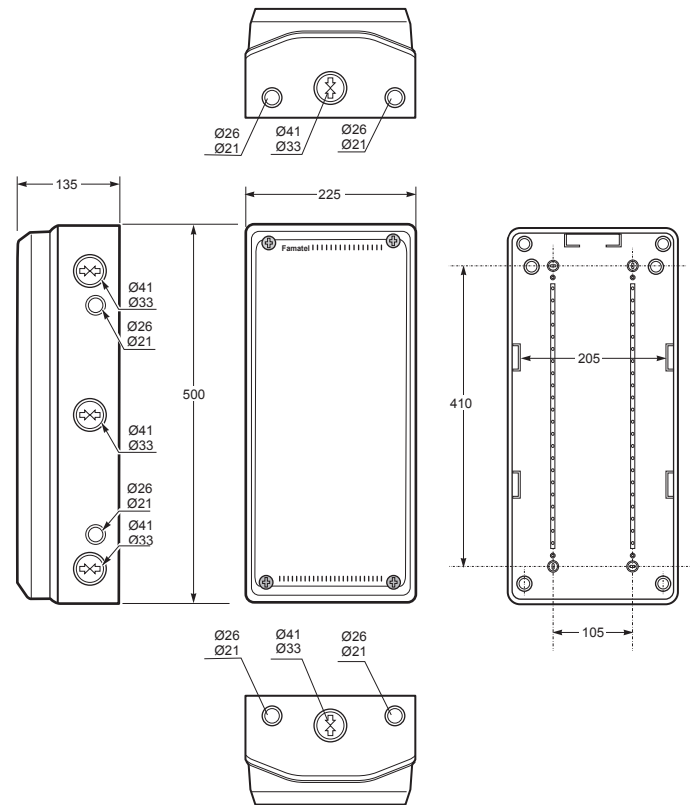

Dimensiones exteriores / External dimensions	
Altura / Height	500
Ancho / Width	225
Profundidad / Deep	135

Entradas / Entries	
Superior / Top	2 x Ø 32-40 + 2 x Ø 20-25 + 1 x Ø 40-50
Inferior / Bottom	2 x Ø 32-40 + 2 x Ø 20-25
Lado / Side	6 x Ø 32-40 + 4 x Ø 20-25

Norma / Norm: EN60670-22



- Tapa y base en ABS
- Sujeción tapa al abrir la tapa
- Entradas pretroqueladas para entrada tubo métrica
- Enlazables

- Cover and base in ABS
- Door hinges
- Knock outs
- Linkables



Ref. Item
3953

Caja ciega IP65 / Blind box IP65 - Ref. Item **3954**

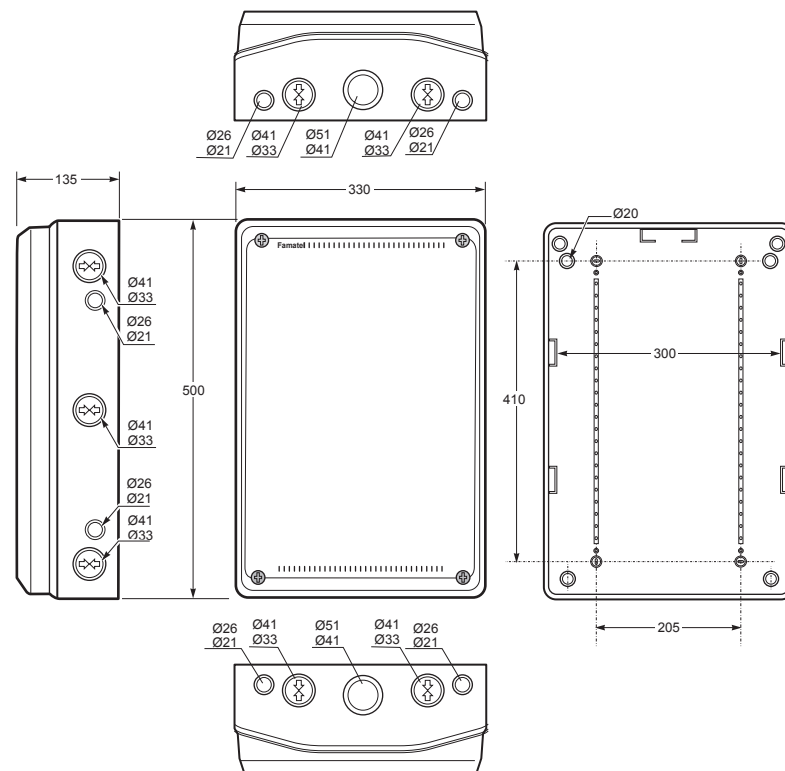

Dimensiones exteriores / External dimensions	
Altura / Height	500
Ancho / Width	330
Profundidad / Deep	135

Entradas / Entries	
Superior / Top	2 x Ø 32-40 + 2 x Ø 20-25 + 1 x Ø 40-50
Inferior / Bottom	2 x Ø 32-40 + 2 x Ø 20-25 + 1 x Ø 40-50
Lado / Side	6 x Ø 32-40 + 4 x Ø 20-25

Norma / Norm: EN60670-22



- Tapa y base en ABS
- Sujeción tapa al abrir la tapa
- Entradas pretroqueladas para entrada tubo métrica
- Enlazables

- Cover and base in ABS
- Door hinges
- Knock outs
- Linkables



Ref. Item
3954

CAJAS ESTANCAS ESPECIALES IP55 / SPECIAL SEALED BOXES IP55

Caja estanca IP55 / Sealed box IP55 - Ref. Item **3092** 4 32

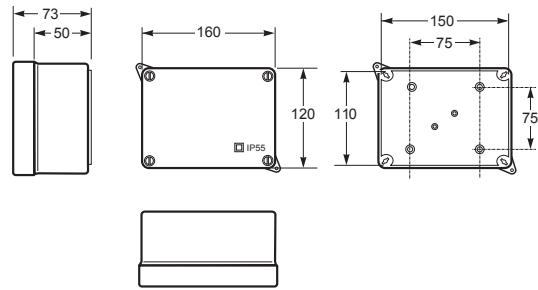

Dimensiones interiores / Internal dimensions	
Altura / Height	110
Ancho / Width	153
Profundidad / Deep	63

Norma / Norm: EN60670-22



- Incluye puente neutro 100A
- Tapa y base en ABS
- Sujeción tapa al abrir la tapa
- Tornillos 1/4 vuelta
- Included Neutral connection bar 100A
- Cover and base in ABS
- Door hinges
- 1/4 turn screw



Ref. Item **3092**

Caja estanca IP55 / Sealed box IP55 - Ref. Item **3084** 2 48

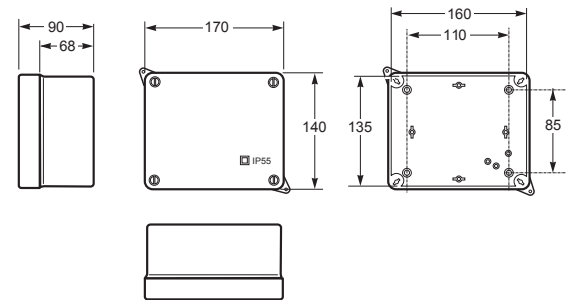

Dimensiones interiores / Internal dimensions	
Altura / Height	135
Ancho / Width	160
Profundidad / Deep	83

Norma / Norm: EN60670-22



- Incluye fusible unipolar 63A + borne 16 mm²
- Tapa y base en ABS
- Sujeción tapa al abrir la tapa
- Tornillos 1/4 vuelta
- Included fuse holder unipolar 63A + borne connection 16 mm²
- Cover and base in ABS
- Door hinges
- 1/4 turn screw



Ref. Item **3084**

Caja estanca IP55 / Sealed box IP55 - Ref. Item **3085** 2 48

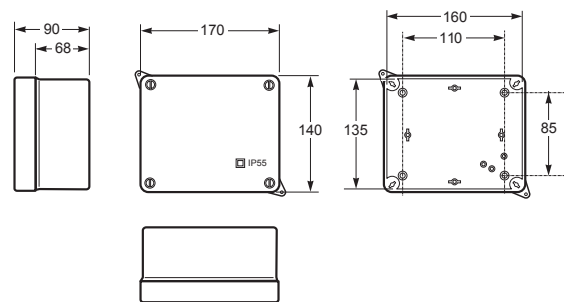

Dimensiones interiores / Internal dimensions	
Altura / Height	135
Ancho / Width	160
Profundidad / Deep	83

Norma / Norm: EN60670-22



- Incluye fusible bipolar 63A + borne 16 mm²
- Tapa y base en ABS
- Sujeción tapa al abrir la tapa
- Tornillos 1/4 vuelta
- Included fuse holder bipolar 63A + borne connection 16 mm²
- Cover and base in ABS
- Door hinges
- 1/4 turn screw



Ref. Item **3085**

Caja estanca IP55 / Sealed box IP55 - Ref. Item **3086** 2 48

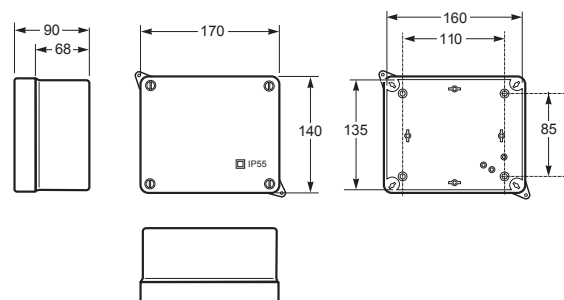

Dimensiones interiores / Internal dimensions	
Altura / Height	135
Ancho / Width	160
Profundidad / Deep	83

Norma / Norm: EN60670-22



- Incluye fusible tripolar 63A + borne 16 mm²
- Tapa y base en ABS
- Sujeción tapa al abrir la tapa
- Tornillos 1/4 vuelta
- Included fuse holder tripolar 63A + borne connection 16 mm²
- Cover and base in ABS
- Door hinges
- 1/4 turn screw



Ref. Item **3086**

CAJAS ESTANCAS PRECABLEADAS IP54 / PRE-WIRED SEALED BOXES IP54

Caja precableada IP54 / Pre-wired box IP54 - Ref. Item **3061** 1 36

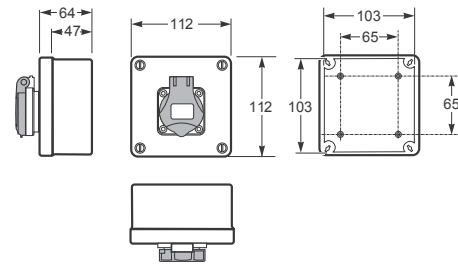

Dimensiones interiores / Internal dimensions	
Altura / Height	100
Ancho / Width	100
Profundidad / Deep	55

Norma / Norm: EN60670-22



- Incluye una toma precableada de corriente 2P+TT 16A-250V~
- Tapa y base en ABS
- Sujeción tapa al abrir la tapa
- Tornillos 1/4 vuelta
- Included one pre-wired socket with lateral earth 16A-250V~
- Cover and base in ABS
- Door hinges
- 1/4 turn screw



Ref. Item
3061

Caja precableada IP54 / Pre-wired box IP54 - Ref. Item **3064** 1 28

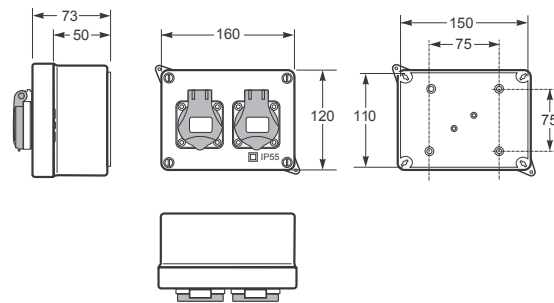

Dimensiones interiores / Internal dimensions	
Altura / Height	110
Ancho / Width	150
Profundidad / Deep	63

Norma / Norm: EN60670-22



- Incluye dos tomas precableadas de corriente 2P+TT 16A-250V~
- Tapa y base en ABS
- Sujeción tapa al abrir la tapa
- Tornillos 1/4 vuelta
- Included two pre-wired sockets with lateral earth 16A-250V~
- Cover and base in ABS
- Door hinges
- 1/4 turn screw



Ref. Item
3064

Caja precableada IP54 / Pre-wired box IP54 - Ref. Item **3065** 1 18

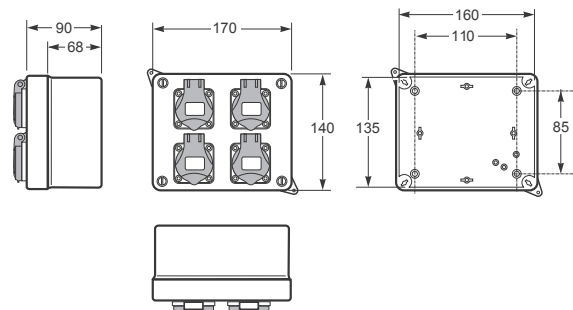

Dimensiones interiores / Internal dimensions	
Altura / Height	135
Ancho / Width	160
Profundidad / Deep	83

Norma / Norm: EN60670-22



- Incluye cuatro tomas precableadas de corriente 2P+TT 16A-250V~
- Tapa y base en ABS
- Sujeción tapa al abrir la tapa
- Tornillos 1/4 vuelta
- Included four pre-wired sockets with lateral earth 16A-250V~
- Cover and base in ABS
- Door hinges
- 1/4 turn screw



Ref. Item
3065

Caja precableada IP54 / Pre-wired box IP54 - Ref. Item **3066** 1 10

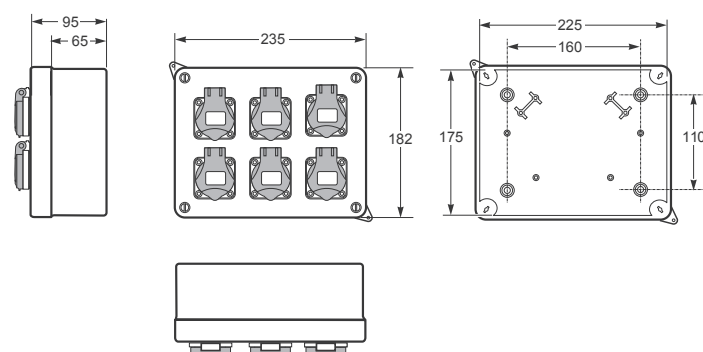

Dimensiones interiores / Internal dimensions	
Altura / Height	175
Ancho / Width	225
Profundidad / Deep	85

Norma / Norm: EN60670-22



- Incluye seis tomas precableadas de corriente 2P+TT 16A-250V~
- Tapa y base en ABS
- Sujeción tapa al abrir la tapa
- Tornillos 1/4 vuelta
- Included six pre-wired sockets with lateral earth 16A-250V~
- Cover and base in ABS
- Door hinges
- 1/4 turn screw



Ref. Item
3066

CAJAS ESTANCAS PRECABLEADAS IP44 / PRE-WIRED SEALED BOXES IP44

Caja precableada IP44 / Pre-wired box IP44 - Ref. Item **3067** 1 1

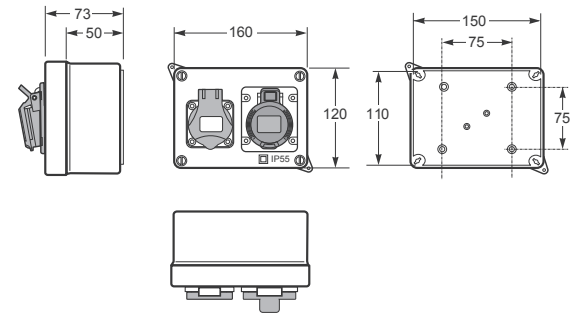

Dimensiones interiores / Internal dimensions	
Altura / Height	110
Ancho / Width	153
Profundidad / Deep	63

Norma / Norm: EN60670-22

* Para otras configuraciones soliciten presupuesto indicando modelo de caja y configuración.

* For other configurations, please request quotation indicating models of boxes and its configuration.



- Incluye: una toma precableada de corriente 2P+TT 16A-250V- una toma de corriente 3P+T 16A-380V-
- Tapa y base en ABS
- Sujeción tapa al abrir la tapa
- Tornillos 1/4 vuelta
- Included: one pre-wired socket with lateral earth 16A-250V- one socket 3P+T 16A-380V-
- Cover and base in ABS
- Door hinges
- 1/4 turn screw



Ref. Item **3067**

Caja precableada IP44 / Pre-wired box IP44 - Ref. Item **3069** 1 1

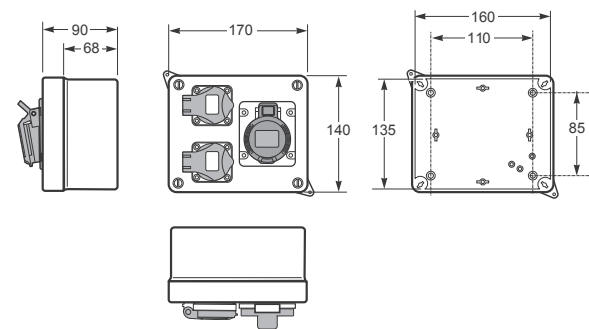

Dimensiones interiores / Internal dimensions	
Altura / Height	135
Ancho / Width	160
Profundidad / Deep	83

Norma / Norm: EN60670-22

* Para otras configuraciones soliciten presupuesto indicando modelo de caja y configuración.

* For other configurations, please request quotation indicating models of boxes and its configuration.



- Incluye: dos tomas precableada de corriente 2P+TT 16A-250V- una toma de corriente 3P+T 16A-380V-
- Tapa y base en ABS
- Sujeción tapa al abrir la tapa
- Tornillos 1/4 vuelta
- Included: two pre-wired sockets with lateral earth 16A-250V- one socket 3P+T 16A-380V-
- Cover and base in ABS
- Door hinges
- 1/4 turn screw



Ref. Item **3069**

ACCESORIOS / ACCESSORIES

Placas metálicas / Zinc plated steel plates

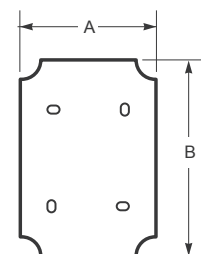

Ref./ Item	Dimensions	
	A	B
3053	120	140
3054	150	200
3055	230	290



Prensaestopas / Cable glands

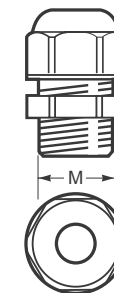

Prensaestopas Cable glands Ref./ Item	Contratuercas Nuts Ref./ Item	Métrica Metric	Unidades bolsa Bag units
3930	3940	M15	50
3933	3943	M20	50
3934	3944	M25	25
3935	3945	M32	20
3936	3946	M40	10
3937	3947	M50	10
3938	3948	M63	10



Guía metálica / DIN Rail

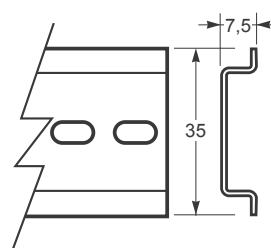

Ref. / Item	3050
-------------	-------------

- Guía DIN para Refs: 3013 / 3043 / 3073
- Rail DIN for Refs: 3013 / 3043 / 3073



9 MIRILLAS DE MANIOBRA IP66/67 HINGLED WINDOW-FUSE WINDOWS IP66/67

Las nueva gama de mirillas IP67 de Famatel cubre las necesidades de cualquier instalación. Fabricadas en policarbonato aseguran una alta resistencia mecánica así como a cualquier agente externo. Su sistema de bisagra ha sido diseñado para asegurar un perfecto cierre.

The new range of IP67 mirrors from Famatel covers the needs of any installation. Manufactured in polycarbonate ensure a high mechanical strength as well as any external agent. Its hinge system has been designed to ensure a perfect closure.

- Fabricadas en policarbonato
 - Alta resistencia a los agentes externos
 - Gama de 2 a 18 módulos
- Manufactured in polycarbonate
 - High resistance to external agents
 - Range from 2 to 18 modules



Marco fabricado en policarbonato resistente a los golpes con junta integrada para montaje en cuadro
Mounting frame made of shock-resistant polycarbonate with integrated gasket for flange mounting



Todas las partes metálicas resistentes a la corrosión
All metal parts corrosion-resistant



Ventana abatible
Hinged window



Tamaño de la ventana abatible adecuada para módulos (17,5 mm cada uno).
Gama de 2 a 18 módulos
Size of hinged window suitable for modules (17,5 mm each).
Range from 2 to 18 modules.

9 MIRILLAS DE MANIOBRA IP66/67
HINGLED WINDOW-FUSE WINDOWS IP66/67

MIRILLAS DE MANIOBRA / FUSE WINDOWS

Características técnicas:

- Diseño compacto y robusto, fabricadas con polycarbonato resistente a los golpes.
- Para OEM's, integradores, etc.
- Tamaño de la ventana abatible adecuada para módulos (17,5 mm cada uno).
- Marco fabricado con polycarbonato resistente a los golpes con junta integrada para montaje en cuadro.
- Todas las partes de metal resistentes a la corrosión.
- Hermético IP66/67.

Características técnicas:

- Especially compact (robust) design, made of shock-resistant polycarbonate.
- For distributor's construction, O.E.M's, panel builders, etc.
- Size of hinged window suitable for modules 17,5 mm esch.
- Mounting frame made of shock-resistant polycarbonate with integrated gasket for flange mounting.
- All metal parts corrosion-resistant.
- IP66/67 watertight.

Mirillas de maniobra 2/4 módulos / Hinged windows 2/4 modules

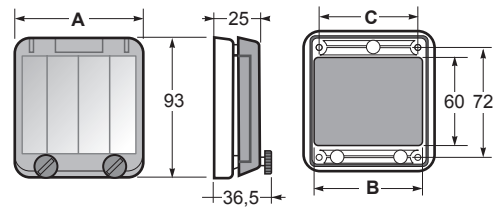

* Incluye plantilla para montaje
* Include template for mounting

Ref. / Item	Módulos Modules	Dimensions			Peso Weight (g)	Pack unit
		A	B	C		
23003	2	49	27	32	51	40
23004	4	85	65	72	80	20



Mirillas de maniobra de 5 hasta 13 módulos
Hinged windows from 5 to 13 modules

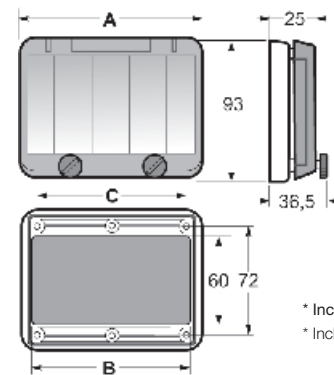

* Incluye plantilla para montaje
* Include template for mounting

Ref. / Item	Módulos Modules	Dimensions			Peso Weight (g)	Pack unit
		A	B	C		
23005	5	103	41,5	90	90	20
23006	6	121	50,5	108	102	15
23007	7	139	59,5	126	114	15
23008	8	157	68,5	144	126	15
23009	9	175	77,5	162	133	15
23010	10	193	86,5	180	145	15
23011	12	229	104,5	216	168	10
23012	13	247	113,5	234	180	10

Mirillas de maniobra 18 módulos / Hinged windows 18 modules

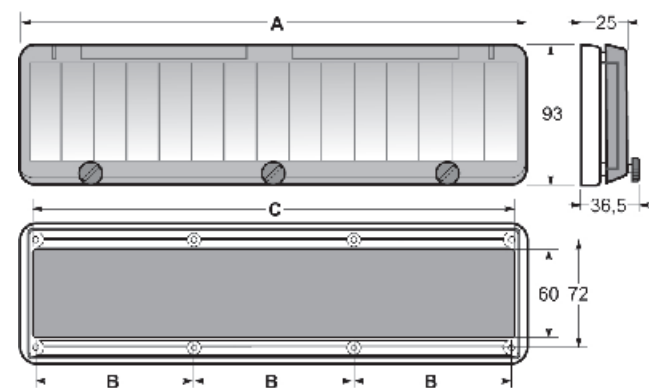

* Incluye plantilla para montaje
* Include template for mounting

Ref. / Item	Módulos Modules	Dimensions			Peso Weight (g)	Pack unit
		A	B	C		
23013	18	337	105	324	245	12



ACCESORIOS / ACCESSORIES

Accesorio precinto para IP66/67
Locking and lead-sealing device - Ref. Item **1828**

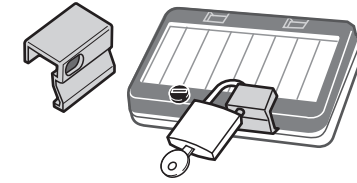

Accesorio para montar carril DIN
Mounting clamp for DIN-RAIL - Ref. Item **1829**

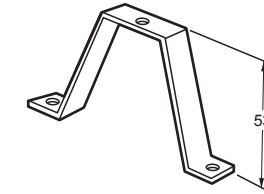

ÍNDICE POR REFERENCIAS
INDEX BY ITEMS

Ref. / Item	Pg.	Ref. / Item	Pg.	Ref. / Item	Pg.	Ref. / Item	Pg.	Ref. / Item	Pg.
187-G	97	3064	241	3923	160	3957.9	165	6301	166
1106	97	3065	241	3926	211	3958	139	6302	166
1107	97	3066	241	3926-T	207	3958.1	165	6303	166
1828	247	3067	243	3926-TB	212	3958.2	165	6304	166
1829	247	3069	243	3926-TB1	212	3958.3	165	6305	166
1830	98	3071	229	3926-TTB	212	3958.4	165	6306	166
1831	98	3072	229	3926-TTB1	212	3958.5	165	6401	164
1832	98	3073	231	3927	133	3958.6	165	6402	164
1833	189	3074	231	3928	141	3959	139	6403	164
1834	189	3075	231	3930	243	3960	141	6404	164
2106	97	3084	239	3933	243	3961	143	6405	168
2107	97	3085	239	3934	243	3962	143	6406	164
2108	97	3086	239	3935	243	3963	147	6407	164
2109	97	3092	239	3936	243	3964	155	6408	164
3001	221	3900	160-213	3937	243	3966	147	6409	164
3002	221	3901	160	3938	243	3967	147	6410	164
3002-GL	223	3902	160	3940	243	3968	147	6412	168
3003	223	3902-T	205	3942	211	3969	151	6501	164
3005	221	3902-TTB	212	3942-T	207	3970	151	6502	164
3005B	221	3902-TTB1	212	3942-TB	212	3973	153	6503	164
3011	223	3903	160	3942-TB1	212	3974	135	6504	164
3012	225	3904	209	3942-TTB	212	3975	141	6505	168
3013	225	3904-T	205	3942-TTB1	212	3977	137	6506	164
3014	227	3904-TB	212	3943	243	3978	145	6507	164
3015	227	3904-TTB	212	3944	243	3979	153	6508	164
3031	223	3905	77	3945	243	3980	181	6509	164
3032	225	3905	160	3946	243	3980P	181	6511	164
3033	225	3907	160	3947	243	3981	180	6512	164
3034	227	3908	209	3948	243	3982	180	6513	164
3035	227	3908-T	205	3950	133	3983	181	6601	164
3042	233	3908-TB	212	3951	133	3984	181	6602	164
3043	233	3908-TTB	212	3952	135	6020	169	6603	164
3044	233	3908-TTB1	212	3953	157-237	6021	169	6604	164
3045	233	3909	160	3954	159-237	6051	167	6605	164
3050	219-242	3910	160	3955	155-235	6052	167	6606	164
3051	219	3911	160	3956	157-235	6053	167	6701	170
3052	219	3912	209	3957	139	6054	167	6702	170
3053	242	3912-T	205	3957.1	165	6151	173	6703	171
3054	242	3912-TB	212	3957.11	173	6152	174	6704	171
3055	242	3912-TTB	212	3957.2	165	6153	174	6705	172
3056	219	3915	160	3957.3	165	6154	175	6706	172
3059	219	3916	160	3957.4	165	6155	175	6901	167
3061	241	3917	160-189	3957.5	165	6201	166	6902	167
3062	229	3918	160	3957.7	165	6202	166	6903	167
3063	229	3919	160	3957.8	165	6203	166	6904	167

Ref. / Item	Pg.	Ref. / Item	Pg.	Ref. / Item	Pg.	Ref. / Item	Pg.	Ref. / Item	Pg.	Ref. / Item	Pg.	Ref. / Item	Pg.	Ref. / Item	Pg.	Ref. / Item	Pg.		
6905	167	13372	27	13636	27	13863	29	14200CR	47	14382	29	14743	27	15027	107	16030	107	23103	31
13000	104	13373	27	13637	27	13864	29	14201	23	14400	23	14800	83	15028	107	16031	107	23104	31
13011	104	13374	27	13638	27	13865	29	14202	23	14401	23	14801	83	15029	107	16032	109	23105	31
13100	23	13375	27	13641	27	13866	29	14203	23	14402	23	14820	83	15030	107	16033	109	23130	37
13101	23	13400	23	13642	27	13900	83	14204	23	14403	23	14821	83	15031	107	16034	109	23131	37
13102	23	13401	23	13643	27	13901	83	14205	23	14404	23	14841	27	15032	109	16035	109	23132	37
13103	23	13402	23	13661	29	13910	104	14206	23	14405	23	14842	27	15033	109	16036	109	23133	37
13104	23	13403	23	13662	29	13910F	104	14208	23	14406	23	14843	27	15034	109	16037	109	23134	37
13105	23	13404	23	13663	29	13912	104	14209	23	14407	23	14864	29	15035	109	16038	109	23135	37
13150	25	13405	23	13664	29	13913	104	14210	23	14408	23	14866	29	15036	109	16039	109	23150	33
13151	25	13410	96	13665	29	13914	104	14211	23	14409	23	14867	29	15037	109	16040	109	23151	33
13152	25	13450	25	13666	29	13920	83	14212	23	14410	23	14868	29	15038	109	16041	109	23152	33
13153	25	13451	25	13700	83	13921	83	14250	25	14411	23	14869	29	15039	109	23000	43	23153	33
13154	25	13452	25	13701	83	13950	76	14251	25	14450	25	14870	29	15040	109	23001	43	23154	33
13155	25	13453	25	13720	83	13952	76	14252	25	14451	25	14900	83	15041	109	23002	43	23155	33
13200	23	13454	25	13721	83	13953	76	14253	25	14452	25	14901	83	16000	109	23003	98-246	23170	35
13200CR	47	13455	25	13731	27	13953F	76	14254	25	14453	25	14920	83	16001	109	23004	98-246	23171	35
13201	23	13483	27	13732	27	13954F	76	14256	29	14456	25	14921	83	16002	107	23005	98-246	23172	35
13202	23	13501	29	13733	27	13955	77	14259	25	14457	25	15000	109	16003	107	23006	98-246	23173	35
13203	23	13502	29	13741	27	13956	76	14300	23	14505	29	15001	109	16004	107	23007	98-246	23174	35
13204	23	13503	29	13742	27	13956F	76	14300CR	47	14506	29	15002	105	16005	107	23008	98-246	23175	35
13206	23	13504	29	13743	27	13957	76	14301	23	14508	29	15002E	105	16006	111	23009	98-246	23190	39
13250	25	13505	29	13761	29	13957F	76	14301CR	47	14509	29	15002F	105	16007	111	23010	98-246	23191	39
13251	25	13506	29	13762	29	13960	77	14302	23	14510	29	15003	111	16008	111	23011	98-246	23192	39
13252	25	13531	27	13763	29	13960F	77	14303	23	14541	27	15004	111	16009	107	23012	98-246	23193	39
13253	25	13532	27	13764	29	14100	23	14304	23	14542	27	15005	111	16010	105	23013	98-246	23194	39
13254	25	13533	27	13765	29	14101	23	14305	23	14543	27	15006	107	16010E	105	23070	89	23195	39
13255	25	13534	27	13766	29	14102	23	14306	23	14600	83	15007	107	16010F	105	23072	89	23196	39
13300	23	13535	27	13800	83	14103	23	14307	23	14601	83	15008	107	16013	107	23073	89	23197	39
13300CR	47	13536	27	13801	83	14108	23	14308	90	14620	83	15009	107	16014	107	23074	89	23198	39
13301	23	13537	27	13820	83	14109	23	14309	23	14621	83	15010	107	16015	107	23075	89	23199	39
13301CR	47	13538	27	13821	83	14110	23	14310	23	14641	27	15013	107	16016	107	23076	89	23200	31
13302	23	13539	27	13831	27	14111	23	14311	23	14642	27	15014	107	16017	107	23077	89	23200CR	47
13303	23	13541	27	13832	27	14112	23	14312	23	14643	27	15015	107	16018	107	23078	89	23201	31
13304	23	13542	27	13833	27	14113	23	14350	25	14665	29	15016	107	16019	107	23079	89	23202	31
13305	23	13543	27	13834	27	14114	23	14351	25	14666	29	15017	107	16020	107	23080	89	23203	31
13350	25	13600	83	13835	27	14115	23	14352	25	14667	29	15018	107	16021	107	23081	89	23204	31
13351	25	13601	83	13836	27	14150	25	14353	25	14668	29	15019	107	16022	107	23082	89	23205	31
13352	25	13620	83	13837	27	14151	25	14354	29	14669	29	15020	107	16023	107	23082	89	23206	39
13353	25	13621	83	13838	27	14152	25	14355	29	14700	83	15021	107	16024	107	23084	89	23207	39
13354	25	13631	27	13839	27	14153	25	14358	29	14701	83	15022	107	16025	107	23085	89	23230	37
13355	25	13632	27	13841	27	14154	29	14363	25	14720	83	15023	107	16026	107	23086	89	23231	37
13366	27	13633	27	13842	27	14159	25	14364	25	14721	83	15024	107	16027	107	23100	31	23232	37
13370	27	13634	27	13861	29	14160	25	14380	29	14741	27	15025	107	16028	107	23101	31	23233	37
13371	27	13635	27	13862	29	14200	23	14381	29	14742	27	15026	107	16029	107	23102	31	23234	37

Ref. / Item	Pg.	Ref. / Item	Pg.	Ref. / Item	Pg.	Ref. / Item	Pg.	Ref. / Item	Pg.	Ref. / Item	Pg.	Ref. / Item	Pg.	Ref. / Item	Pg.	Ref. / Item	Pg.		
23235	37	23311.6	188	23405	31	23701	85	24176	35	24256	41	24336	37	24413	31	24621	85	25019	53
23250	33	23311.7	188	23406	39	23720	85	24180	35	24257	41	24339	90	24430	37	24700	85	25020	53
23251	33	23311.8	188	23407	39	23721	85	24181	35	24258	41	24340	37	24431	37	24701	85	25021	53
23252	33	23312	186	23410	96	23800	85	24182	35	24259	41	24341	37	24432	37	24720	85	25022	53
23253	33	23312.1	188	23430	37	23801	85	24184	35	24261	41	24350	33	24433	37	24721	85	25023	53
23254	33	23312.2	188	23431	37	23820	85	24185	35	24270	35	24351	33	24434	37	24800	85	25024	53
23255	33	23312.3	188	23432	37	23821	85	24190	41	24271	35	24352	33	24437	37	24801	85	25031	53
23270	35	23312.4	188	23433	37	23900	85	24191	41	24272	35	24353	33	24438	37	24820	85	25032	53
23271	35	23312.5	188	23434	37	23901	85	24192	41	24273	35	24354	33	24441	37	24821	85	25033	53
23272	35	23312.6	188	23435	37	23920	85	24193	41	24274	35	24355	33	24442	37	24900	85	25034	53
23273	35	23312.7	188	23450	33	23921	85	24194	41	24275	35	24370	35	24450	33	24901	85	25035	53
23274	35	23312.8	188	23451	33	23960	77	24195	41	24279	35	24371	35	24451	33	24920	85	25036	53
23275	35	23312.9	188	23452	33	24100	31	24196	41	24280	35	24372	35	24452	33	24921	85	25037	53
23290	39	23330	37	23453	33	24101	31	24197	41	24281	35	24373	35	24453	33	24960	77	25038	53
23291	39	23331	37	23454	33	24102	31	24198	41	24282	35	24374	35	24454	33	24961	77	25039	53
23292	39	23332	37	23455	33	24103	31	24199	41	24284	35	24375	35	24455	33	24980	89	25040	53
23293	39	23333	37	23470	35	24104	31	24200	31	24285	35	24376	35	24470	35	24981	89	25041	53
23295	39	23334	37	23471	35	24106	31	24200CR	47	24290	41	24377	35	24471	35	24982	89	25042	53
23296	39	23335	37	23472	35	24107	31	24201	31	24291	41	24378	35	24472	35	24983	89	25043	53
23297	39	23350	33	23473	35	24109	31	24202	31	24292	41	24379	35	24473	35	24984	89	25044	53
23298	39	23351	33	23474	35	24111	31	24203	31	24293	41	24380	35	24474	35	24985	89	25045	53
23299	39	23352	33	23475	35	24112	31	24204	31	24295	41	24381	35	24475	35	24990	89	25046	53
23300	31	23353	33	23480	96	24113	31	24205	31	24296	41	24390	41	24480	35	24991	89	25047	53
23300CR	47	23354	33	23481	39	24114	31	24206	31	24297	41	24391	41	24481	35	24992	89	25048	53
23301	31	23355	33	23482	39	24130	37	24208	31	24300	31	24392	41	24482	35	24993	89	25049	53
23301CR	47	23370	35	23483	39	24131	37	24209	31	24300CR	47	24393	41	24483	35	24994	89	25050	53
23302	31	23371	35	23484	39	24132	37	24210	31	24301	31	24394	41	24484	35	24995	89	25051	53
23303	31	23372	35	23485	39	24133	37	24211	31	24301CR	47	24395	41	24485	35	24996	89	25052	53
23304	31	23373	35	23486	39	24134	37	24212	31	24302	31	24396	41	24486	41	24997	89	25053	91
23305	31	23374	35	23490	39	24135	37	24213	41	24303	31	24397	41	24487	41	24998	89	25054	57
23306	39	23375	35	23491	39	24137	37	24230	37	24304	31	24398	90	24488	41	24999	89	25055	57
23307	39	23390	39	23492	39	24138	37	24231	37	24305	31	24399	41	24489	41	25000	53	25056	57
23308	39	23392	39	23493	39	24141	37	24232	37	24306	31	24400	31	24490	41	25001	53	25057	57
23310	186	23393	39	23494	39	24150	33	24233	37	24307	31	24401	31	24491	41	25002	53	25058	57
23310.1	188	23394	39	23495	39	24151	33	24234	37	24308	90	24402	31	24492	41	25003	53	25059	57
23310.2	188	23395	39	23600	85	24152	33	24235	37	24310	31	24403	31	24493	41	25004	53	25060	57
23310.3	188	23396	39	23601	85	24153	33	24236	37	24311	31	24404	31	24494	41	25005	53	25061	57
23310.4	188	23397	39	23602	43	24154	33	24238	37	24312	31	24405	31	24496	41	25006	67	25063	57
23310.5	188	23398	39	23605	43	24155	33	24240	37	24313	31	24406	31	24497	41	25007	67	25064	57
23311	186	23399	39	23606	43	24170	35	24250	33	24330	37	24407	31	24498	41	25008	57	25065	57
23311.1	188	23400	31	23609	43	24171	35	24251	33	24331	37	24408	41	24499	41	25009	57	25066	57
23311.2	188	23401	31	23620	85	24172	35	24252	33	24332	37	24409	41	24512	41	25010	57	25067	57
23311.3	188	23402	31	23621	85	24173	35	24253	33	24333	37	24410	31	24600	85	25011	57	25068	57
23311.4	188	23403	31	23691	39	24174	35	24254	33	24334	37	24411	31	24601	85	25012	57	25069	57
23311.5	188	23404	31	23700	85	24175	35	24255	33	24335	37	24412	31	24620	85	25013	57	25070	57

Ref. / Item	Pg.	Ref. / Item	Pg.	Ref. / Item	Pg.	Ref. / Item	Pg.	Ref. / Item	Pg.	Ref. / Item	Pg.	Ref. / Item	Pg.	Ref. / Item	Pg.	Ref. / Item	Pg.		
25071	57	25141	59	25330	69	25546	87	25720	61	26027	55	26335	63	31010	113	31055	115	PL-39134	195
25072	57	25144	59	25331	69	25547	87	25721	61	26028	91	26336	63	31011	113	31056	115	PL-39145	195
25073	57	25145	59	25332	69	25548	87	25722	61	26029	55	26337	63	31012	113	31057	115	PL-39146	195
25074	92	25146	59	25333	69	25549	87	25723	61	26030	55	26501	65	31013	113	31058	115	PL-39157	195
25075	53	25147	59	25334	69	25550	87	25724	61	26031	55	26502	65	31014	115	31059	115	PL-39168	195
25076	53	25148	59	25335	69	25551	87	25725	61	26032	55	26503	65	31015	115	31060	115	RG-04	213
25077	57	25149	59	25336	69	25552	87	25726	61	26033	55	26504	65	31016	115	31062	115	RG-12	160-213
25078	57	25150	59	25337	69	25553	87	25727	93	26034	55	26505	65	31017	115	31063	113	SPT18/36	199-201
25079	57	25151	59	25338	69	25554	87	25728	61	26035	55	26506	65	31018	115	31064	113	SPTA-12	160-213
25080	57	25152	71	25501	125	25555	87	25729	61	26036	55	26507	65	31019	115	31065	113	SPTC-4	160-189 214
25081	57	25153	71	25502	125	25556	87	25730	61	26207	69	26508	65	31020	115	31066	113		
25082	57	25154	71	25503	125	25557	87	25731	61	26301	63	26509	65	31021	115	31067	113		
25085	57	25155	71	25504	125	25558	87	25732	61	26302	63	26510	65	31022	115	31068	113		
25086	57	25156	71	25505	125	25559	87	25733	61	26303	63	26511	65	31023	115	31069	113		
25108	59	25157	71	25506	125	25560	87	25734	61	26304	63	26512	65	31024	115	31070	113		
25109	59	25158	71	25507	125	25561	87	25735	61	26305	63	26513	65	31025	115	31071	113		
25110	59	25159	71	25508	125	25562	87	25736	61	26306	63	26514	94	31026	115	31072	113		
25111	59	25160	71	25509	125	25563	87	25737	61	26307	63	26515	65	31027	115	31073	113		
25112	59	25161	71	25510	125	25564	87	26000	55	26308	63	26516	65	31028	115	31074	113		
25113	59	25162	71	25511	125	25565	87	26001	55	26309	63	26517	65	31029	115	39018	199		
25114	59	25163	71	25512	125	25566	87	26002	55	26310	63	26518	65	31030	115	39036	199		
25115	59	25206	69	25513	125	25567	87	26003	55	26311	63	26519	65	31031	115	39054	199		
25116	59	25208	69	25514	125	25568	87	26004	55	26312	63	26520	65	31032	115	39072	199		
25117	59	25306	67	25515	125	25569	87	26005	55	26313	63	26521	65	31033	115	39103	98		
25118	59	25307	67	25516	125	25570	87	26006	55	26314	63	26522	65	31034	115	39104	98		
25119	59	25308	67	25517	125	25571	87	26007	55	26315	63	26523	65	31035	115	39105	98		
25120	59	25309	67	25518	125	25701	61	26008	55	26316	63	26524	65	31036	115	39106	98		
25121	59	25310	67	25519	125	25702	61	26009	55	26317	63	26525	65	31037	115	39120	195		
25123	59	25311	67	25520	125	25703	61	26010	55	26318	63	30002	120	31038	115	39123	193		
25124	59	25312	67	25521	125	25704	61	26011	55	26319	63	30004	120	31039	115	39134	193		
25125	59	25313	67	25522	125	25705	61	26012	55	26320	63	30013	120	31040	115	39145	193		
25126	59	25314	67	25523	125	25706	61	26013	55	26321	63	30014	120	31041	115	39146	193		
25127	59	25315	67	25524	125	25707	61	26014	55	26322	63	30015	120	31042	115	39157	195		
25128	59	25316	67	25525	125	25708	61	26015	55	26323	63	30016	120	31043	115	39168	195		
25129	59	25317	67	25526	125	25709	61	26016	55	26324	63	30017	121	31044	115	150039570	160		
25130	59	25318	67	25527	125	25710	61	26017	55	26325	63	30018	121	31045	115	150039980	158-160		
25131	59	25320	67	25528	125	25711	61	26018	55	26326	63	30019	121	31046	115	150039981	158-160		
25132	59	25321	67	25529	125	25712	61	26019	55	26327	93	31002	113	31047	115	150039982	159-160		
25133	59	25322	67	25530	125	25713	61	26020	55	26328	63	31003	113	31048	115	150039983	159-160		
25134	59	25323	67	25540	87	25714	61	26021	55	26329	63	31004	113	31049	115	I-39123	194		
25136	92	25324	67	25541	87	25715	61	26022	55	26330	63	31005	113	31050	115	I-39134	194		
25137	57	25325	67	25542	87	25716	61	26023	55	26331	63	31006	113	31051	115	I-39145	194		
25138	57	25326	67	25543	87	25717	61	26024	55	26332	63	31007	113	31052	115	I-39146	194		
25139	57	25327	67	25544	87	25718	61	26025	55	26333	63	31008	113	31053	115	I-39157	194		
25140	59	25328	67	25545	87	25719	61	26026	55	26334	63	31009	113	31054	115	PL-39123	195		

CENTROS DE PRODUCCIÓN
PRODUCTION PLANTS

FAMATEL SPAIN Avda. El Pla 11 P.I. El Pla 08185 Lliçà de Vall Barcelona, Spain Tel. 0034 938 439 940	C/ Vapor 12-14 P.I. La Ferreria 08110 Montcada i Reixac Barcelona, Spain Tel. 0034 938 439 940	Ctra. A-123 km 8.5 22130 Peralta de Alcofea Huesca, Spain Tel. 0034 974 300 732	FAMATEL ITALY Via Marabotto 180, 29010 Castelnuovo Fogliani Alseno PC, Italy Tel. 0039 0523 94 71 66	FAMATEL BULGARIA 176, Brezovsko Shossè Blvd. 4003 Plovdiv Bulgaria Tel. 00359 32 235 023
---	--	---	---	---

FILIALES INTERNACIONALES
INTERNATIONAL SUBSIDIARIES

FAMATEL FR ZA des Murons 23, Rue Jacqueline Auriol 42160 Andrézieux-Bouthéon, France Tel. 0033 477 797 527	FAMATEL UK Unit 1 Mixon Estate Oldmixon Crescent Weston-Super-Mare BS24 9AX North Somerset United Kingdom Tel. 0044 8455 281 068	FAMATEL CZ Olomoucká 107 796 01 Prostějov Czech Republic Tel. 00420 739 201 336	FAMATEL PL Ul. Podwalna 11 58 200 Dzierżoniów Poland Tel. 0048 74 831 51 54	FAMATEL BG 176, Brezovsko Shossè Blvd. 4003 Plovdiv Bulgaria Tel. 00359 32 235 023
FAMATEL IT Via Marabotto 180 29010 Castelnuovo Fogliani Alseno PC Italy Tel. 0039 0523 947166	FAMATEL USA 1231 Stirling Road, Unit 103 Dania Beach, FL 33004 Florida United States of America Tel. +1 954 638 8616			



famatel

Famatel UK Limited
Unit 1 Mixon Estate
Oldmixon Crescent
Weston-super-Mare
North Somerset BS24 9AX
T. 01934 412133 - F. 01908 538054
E. sales@famatel.co.uk
www.famatel.co.uk | www.famatel.com